



Prüfbericht-Nr.: <i>Test report no.:</i>	CN25NMLN 001	Auftrags-Nr.: <i>Order no.:</i>	168541171	Seite 1 von 11 Page 1 of 11
Kunden-Referenz-Nr.: <i>Client reference no.:</i>	1282992	Auftragsdatum: <i>Order date:</i>	2025-03-04	
Auftraggeber: <i>Client:</i>	Huawei Technologies Co., Ltd. Administration Building, Headquarters of Huawei Technologies Co., Ltd. Bantian, Longgang District, Shenzhen, 518129 Guangdong P.R. China			
Prüfgegenstand: <i>Test item:</i>	Solar Inverter			
Bezeichnung / Typ-Nr.: <i>Identification / Type no.:</i>	SUN2000-50K-MC0, SUN2000-40K-MC0, SUN2000-30K-MC0			
Auftrags-Inhalt: <i>Order content:</i>	A3 certificate			
Prüfgrundlage: <i>Test specification:</i>	VDE-AR-N 4105/11.18 <i>Generators connected to the low-voltage distribution network – Technical requirements for the connection to and parallel operation with low-voltage distribution networks</i> DIN VDE V 0124-100/06.20 <i>Grid integration of generator plants – Low-voltage – Test requirements for generator units to be connected to and operated in parallel with low-voltage distribution networks</i>			
Wareneingangsdatum: <i>Date of sample receipt:</i>	2025-03-05			
Prüfmuster-Nr.: <i>Test sample no.:</i>	102527442185			
Prüfzeitraum: <i>Testing period:</i>	2025-03-05 - 2025-08-15			
Ort der Prüfung: <i>Place of testing:</i>	TÜV Rheinland (Shenzhen) Co., Ltd.			
Prüflaboratorium: <i>Testing laboratory:</i>	TÜV Rheinland (Shenzhen) Co., Ltd.			
Prüfergebnis*: <i>Test result*:</i>	Pass			
erstellt von: <i>created by:</i>	genehmigt von: <i>authorized by:</i>			
Datum: <i>Date:</i> 2025-09-11	 Kenny Mai		 Ann Zhang	
Stellung / Position:	Sachverständige(r)/Expert	Stellung / Position:	Sachverständige(r)/Expert	
Sonstiges / Other:	<p>Test procedure complied with DIN VDE V 0124-100/06.20, see report CN25NMLN 001 attachment 1 for detail.</p> <p>This report does not evidence compliance of the provided sample with the relevant standards but only with the referred tests. This test report documents the findings of examination conducted on the delivered product mentioned above only. This report does not entitle the applicant to carry any safety mark on this or similar products. Further for sales or other application purposes of the tested product, any reference to TÜV Rheinland or a test through TÜV Rheinland is only permissible with prior written consent of TÜV Rheinland.</p>			
Zustand des Prüfgegenstandes bei Anlieferung: <i>Condition of the test item at delivery:</i>	Prüfmuster vollständig und unbeschädigt <i>Test item complete and undamaged</i>			
* Legende:	P(ass) = entspricht o.g. Prüfgrundlage(n)	F(ail) = entspricht nicht o.g. Prüfgrundlage(n)	N/A = nicht anwendbar	N/T = nicht getestet
* Legend:	P(ass) = passed a.m. test specification(s)	F(ail) = failed a.m. test specification(s)	N/A = not applicable	N/T = not tested
<p>Dieser Prüfbericht bezieht sich nur auf das o.g. Prüfmuster und darf ohne Genehmigung der Prüfstelle nicht auszugsweise vervielfältigt werden. Dieser Bericht berechtigt nicht zur Verwendung eines Prüfzeichens. <i>This test report only relates to the above mentioned test sample. Without permission of the test center this test report is not permitted to be duplicated in extracts. This test report does not entitle to carry any test mark.</i></p>				

Prüfbericht-Nr.: CN25NMLN 001
Test report no.:

Seite 2 von 11
Page 2 of 11

Anmerkungen
Remarks

- | | |
|---|--|
| 1 | <p>Alle eingesetzten Prüfmittel waren zum angegebenen Prüfzeitraum gemäß eines festgelegten Kalibrierungsprogramms unseres Prüfhauses kalibriert. Sie entsprechen den in den Prüfprogrammen hinterlegten Anforderungen. Die Rückverfolgbarkeit der eingesetzten Prüfmittel ist durch die Einhaltung der Regelungen unseres Managementsystems gegeben.
Detaillierte Informationen bezüglich Prüfkonditionen, Prüfequipment und Messunsicherheiten sind im Prüflabor vorhanden und können auf Wunsch bereitgestellt werden.</p> <p><i>The equipment used during the specified testing period was calibrated according to our test laboratory calibration program. The equipment fulfils the requirements included in the relevant standards. The traceability of the test equipment used is ensured by compliance with the regulations of our management system. Detailed information regarding test conditions, equipment and measurement uncertainty is available in the test laboratory and could be provided on request.</i></p> |
| 2 | <p>Wie vertraglich vereinbart, wurde dieses Dokument nur digital unterzeichnet. Der TÜV Rheinland hat nicht überprüft, welche rechtlichen oder sonstigen diesbezüglichen Anforderungen für dieses Dokument gelten. Diese Überprüfung liegt in der Verantwortung des Benutzers dieses Dokuments. Auf Verlangen des Kunden kann der TÜV Rheinland die Gültigkeit der digitalen Signatur durch ein gesondertes Dokument bestätigen. Diese Anfrage ist an unseren Vertrieb zu richten. Eine Umweltgebühr für einen solchen zusätzlichen Service wird erhoben. Informationen zur Verifizierung der Authentizität unserer Dokumente erhalten Sie auf folgender Webseite: go.tuv.com/digital-signature</p> <p><i>As contractually agreed, this document has been signed digitally only. TUV Rheinland has not verified and unable to verify which legal or other pertaining requirements are applicable for this document. Such verification is within the responsibility of the user of this document. Upon request by its client, TUV Rheinland can confirm the validity of the digital signature by a separate document. Such request shall be addressed to our Sales department. An environmental fee for such additional service will be charged. For information on verifying the authenticity of our documents, please visit the following website: go.tuv.com/digital-signature</i></p> |
| 3 | <p>Prüfklausel mit der Note * wurden an qualifizierte Unterauftragnehmer vergeben und sind unter der jeweiligen Prüfklausel des Berichts beschrieben.
Abweichungen von Prüfspezifikation(en) oder Kundenanforderungen sind in der jeweiligen Prüfklausel im Bericht aufgeführt.</p> <p><i>Test clauses with remark of * are subcontracted to qualified subcontractors and described under the respective test clause in the report.
Deviations of testing specification(s) or customer requirements are listed in specific test clause in the report.</i></p> |
| 4 | <p>Die Entscheidungsregel für Konformitätserklärungen basierend auf numerischen Messergebnissen in diesem Prüfbericht basiert auf der "Null-Grenzwert-Regel" und der "Einfachen Akzeptanz" gemäß ILAC G8:2019 und IEC Guide 115:2023, es sei denn, in der auf Seite 1 dieses Berichts genannten angewandten Norm ist etwas anderes festgelegt oder vom Kunden gewünscht. Dies bedeutet, dass die Messunsicherheit nicht berücksichtigt wird und daher auch nicht im Prüfbericht angegeben wird. Zu weiteren Informationen bezüglich des Risikos durch diese Entscheidungsregel siehe ILAC G8:2019.</p> <p><i>The decision rule for statements of conformity, based on numerical measurement results, in this test report is based on the "Zero Guard Band Rule" and "Simple Acceptance" in accordance with ILAC G8:2019 and IEC Guide 115:2023, unless otherwise specified in the applied standard mentioned on Page 1 of this report or requested by the customer. This means that measurement uncertainty is not taken in account and hence also not declared in the test report. For additional information to the resulting risk based of this decision rule please refer to ILAC G8:2019.</i></p> |

Prüfbericht-Nr.: CN25NMLN 001

Seite 3 von 11

Test Report No.:

Page 3 of 11









Liste der verwendeten Prüfmittel
List of used test equipment

Eq. No.	Inventory No.	Asset No.	Eq. Name	Manufacturer	Model No.	Calibration due	Cal. No.
SZPE-001.1	GC-SZ 022743	96181500003172	AC source	Chroma	61815	2025.11.10	Q12409200003A
SZPE-002.1	GC-SZ 022733	96218050000652	DC source	Chroma	62180D-1800	2025.11.10	Q12409200016A
SZPE-003.1	GC-SZ 022731	618603800854	AC source	Chroma	61860.0	2025.11.10	Q12409200103A
SZPE-008	GC-SZ 022795	93H008000	Islanding	QUNLING Energy	ACLT 3820 N	2025.11.10	Q12409200002A
SZPE-009.1	GC-SZ 022797	93H008001-1	Network impedance	QUNLING Energy	ACLT-6450	2025.11.10	Q12409200132A
SZPE-010	GC-SZ 022644	901A31386	Waveform recorder	YOKOGAWA	DL950-H- HC/M1/ST1/P 4	2025.12.26	S424095427
SZPE-012.1	GC-SZ 022773	MDO34 C067468	Oscilloscope	Tektronix	MSO34-3-BW 500	2025.11.03	Q12409200102
SZPE-013	GC-SZ 022776	MDO34 C071192	High precision oscilloscope	Tektronix	MSO58B-5- BW-500	2025.11.03	Q12409200077A
SZPE-014.1	GC-SZ 022777	TCP0150 C026271	Current probe	Tektronix	TCP0150	2025.11.03	Q12409200053
SZPE-015.1	GC-SZ 022786	THDP0200 C048201	High Voltage Differential probe	Tektronix	THDP0200	2025.11.03	Q12409200069A
SZPE-016.1	GC-SZ 022766	6550200	Digital Multimeter	FLUKE	289/CN	2025.11.12	Q22409770010A
SZPE-017.1	GC-SZ 022647	C8240202-CHN	Power analyzer	DEWETRON	DEWE3-PA8	2025.11.14	Q12409200133
SZPE-018.2	GC-SZ 022656	1241731311	Current Transducer	LEM	IN200-S	2025.11.03	Q12409200061

Prüfbericht-Nr.: CN25NMLN 001
Test Report No.:

Seite 4 von 11
Page 4 of 11

Produktbeschreibung
Product description

1	<p>Produktdetails <i>Product details</i></p>	See below.
<p>Copy of marking plate:</p>		
		
<p>型号 Model: SUN2000-30K-MC0 名称 Name: 太阳能光伏逆变器 SOLAR INVERTER</p>		
<p>最大输入电压 d.c. Max.Input Voltage: 1100 Vd.c. 最大输入电流 d.c. Max.Input Current: 27 A/27 A/27 A/27 A 最大短路电流 Isc: 40 A/40 A/40 A/40 A MPP电压范围 d.c. MPP Range: 180 - 1000 Vd.c. 输出电压 a.c. Output Nominal Voltage: 380/400/480 Va.c.; 3(N)~+⊕ 适配电网频率 a.c. Nominal Operating Frequency: 50/60 Hz 额定视在功率 a.c. Output Rated Apparent Power: 30 kVA 最大视在功率 a.c. Output Max.Apparent Power: 33 kVA 最大输出电流 a.c. Output Max. Current: 50.4 A; 380 Va.c. 47.9 A; 400 Va.c. 39.9 A; 480 Va.c. 额定输出电流 a.c. Output Rated Current: 45.6 A; 380 Va.c. 43.3 A; 400 Va.c. 36.1 A; 480 Va.c.</p>		
		
		
<p>扫码获取支持 Scan for support</p>		
<p>功率因数 Power Factor: 0.8(lagging) - 0.8(leading) 工作环境温度范围 Operating Temperature Range: - 25 - + 60 °C 逆变器拓扑 Inverter Topology: Non - Isolation 防护等级 Enclosure: IP66 保护等级 Protection Class: I 过电压类别 Overvoltage Category: II (DC)/III (AC) 污染等级 Pollution Degree: III 海拔 Altitude: 4000 m 通信方式 Communication: RS485/WLAN 电弧故障保护 AFCI: TYPE I / F - I - AFPE - 1 - 2 - 4</p>		
		
		
<p>华为技术有限公司 HUAWEI TECHNOLOGIES CO., LTD. 中国制造 MADE IN CHINA HQ of Huawei, Bantian, Longgang District, Shenzhen, 518129, P.R.C</p>		
		
<p>型号 Model: SUN2000-40K-MC0 名称 Name: 太阳能光伏逆变器 SOLAR INVERTER</p>		
<p>最大输入电压 d.c. Max.Input Voltage: 1100 Vd.c. 最大输入电流 d.c. Max.Input Current: 27 A/27 A/27 A/27 A 最大短路电流 Isc: 40 A/40 A/40 A/40 A MPP电压范围 d.c. MPP Range: 180 - 1000 Vd.c. 输出电压 a.c. Output Nominal Voltage: 380/400/480 Va.c.; 3(N)~+⊕ 适配电网频率 a.c. Nominal Operating Frequency: 50/60 Hz 额定视在功率 a.c. Output Rated Power: 40 kW 额定视在功率 a.c. Output Rated Apparent Power: 40 kVA 最大视在功率 a.c. Output Max.Apparent Power: 44 kVA 最大输出电流 a.c. Output Max. Current: 67.2 A; 380 Va.c. 63.8 A; 400 Va.c. 53.2 A; 480 Va.c. 额定输出电流 a.c. Output Rated Current: 60.8 A; 380 Va.c. 57.7 A; 400 Va.c. 48.1 A; 480 Va.c.</p>		
		
		
<p>扫码获取支持 Scan for support</p>		
<p>功率因数 Power Factor: 0.8(lagging) - 0.8(leading) 工作环境温度范围 Operating Temperature Range: - 25 - + 60 °C 逆变器拓扑 Inverter Topology: Non - Isolation 防护等级 Enclosure: IP66 保护等级 Protection Class: I 过电压类别 Overvoltage Category: II (DC)/III (AC) 污染等级 Pollution Degree: III 海拔 Altitude: 4000 m 通信方式 Communication: RS485/WLAN 电弧故障保护 AFCI: TYPE I / F - I - AFPE - 1 - 2 - 4</p>		
		
		
<p>华为技术有限公司 HUAWEI TECHNOLOGIES CO., LTD. 中国制造 MADE IN CHINA HQ of Huawei, Bantian, Longgang District, Shenzhen, 518129, P.R.C</p>		

Prüfbericht-Nr.: CN25NMLN 001
Test Report No.:

Seite 5 von 11
Page 5 of 11

Produktbeschreibung Product description



型号 Model: SUN2000-50K-MC0
名称 Name: 太阳能光伏逆变器
SOLAR INVERTER

最大输入电压 d.c. Max.Input Voltage: 1100 Vd.c.
最大输入电流 d.c. Max.Input Current: 30 A/33 A/33 A/30 A
最大短路电流 Isc: 40 A/44 A/44 A/40 A
MPP电压范围 d.c. MPP Range: 180 - 1000 Vd.c.
输出电压 a.c. Output Nominal Voltage: 380/400/480 Va.c.; 3(N)~+⊕
适配电网频率 a.c. Nominal Operating Frequency: 50/60 Hz
额定输出功率 a.c. Output Rated Power: 50 kW
额定视在功率 a.c. Output Rated Apparent Power: 50 kVA
最大视在功率 a.c. Output Max.Apparent Power: 55 kVA
最大输出电流 a.c. Output Max.Current: 84.0 A; 380 Va.c.
79.8 A; 400 Va.c.
66.5 A; 480 Va.c.
额定输出电流 a.c. Output Rated Current: 76.0 A; 380 Va.c.
72.2 A; 400 Va.c.
60.1 A; 480 Va.c.
功率因数 Power Factor: 0.8(lagging) - 0.8(leading)
工作环境温度范围 Operating Temperature Range: - 25 - + 60 °C
逆变器拓扑 Inverter Topology: Non - Isolation
防护等级 Enclosure: IP66
保护等级 Protection Class: I
过电压类别 Overvoltage Category: II (DC)/III (AC)
污染等级 Pollution Degree: III
海拔 Altitude: 4000 m
通信方式 Communication: MBUS/RS485/WLAN
电弧故障保护 AFCI: TYPE I /F - I - AFPE - 1 - 2 - 4

合格证
QC PASS



扫码获取支持
Scan for support



华为技术有限公司 HUAWEI TECHNOLOGIES CO., LTD. 中国制造 MADE IN CHINA
HQ of Huawei, Bantian, Longgang District, Shenzhen, 518129, P.R.C

Importer:

Telephone:

Address:

Produktbeschreibung
Product description

General product information:

Product Description:

The PCE under test (EUT) is SOLAR INVERTER (Grid-connected PV inverter), three-phase grid-tied PV string inverter that converts the DC power generated by PV modules into AC power and feeds the electricity into the power grid.

Maximum operating altitude 4000 m. Operating ambient temperature -25°C to +60°C

The system diagram block is shown as below:

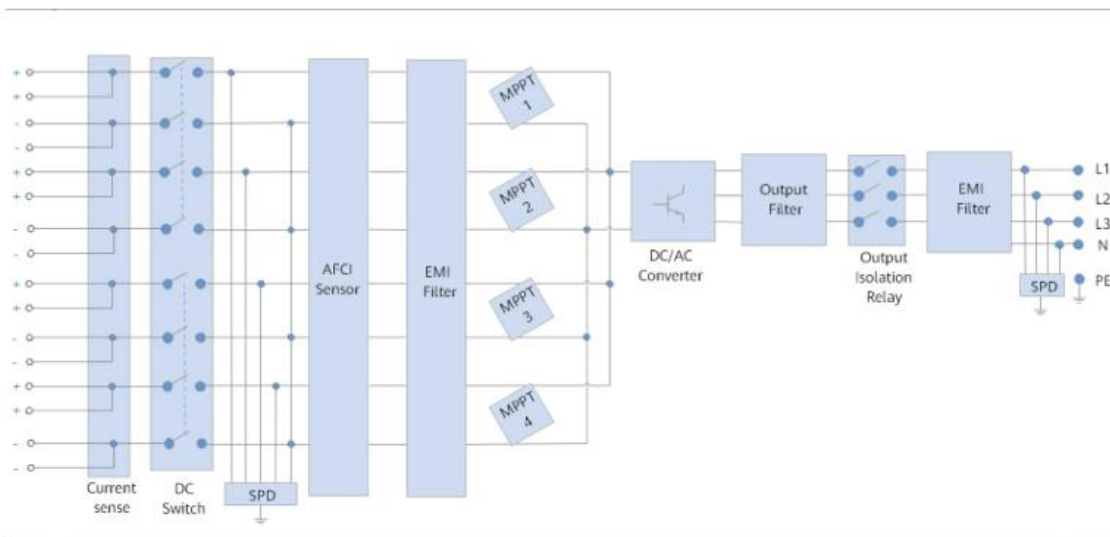

P_{AV,E} monitoring device and scheme:

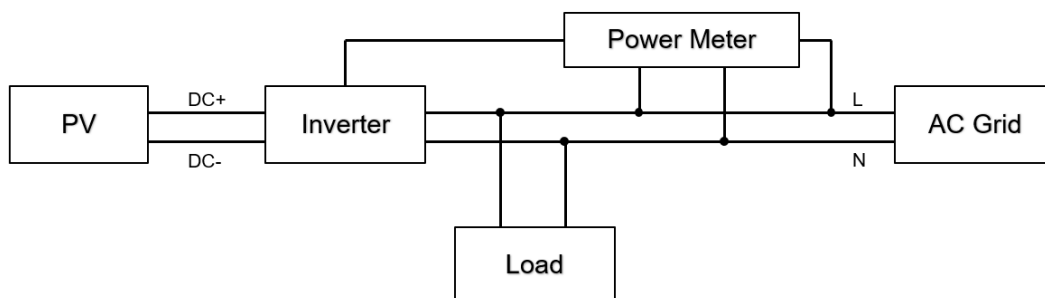

The user can set the export limit(Power Meter) through the monitoring platform of the Converter to control the power output from the converter to the grid.

Export Restriction Control Procedures:

- 1.Select Export limitation setting
- 2.Enter password: XXX
- 3.Select setup type and enter the export limit value

Meter:

Meter Model: YDS60-C24

Manufacturer: Guangdong Yada Electronics Co.,Ltd.

Prüfbericht-Nr.: CN25NMLN 001
Test Report No.:

Seite 7 von 11
Page 7 of 11

Produktbeschreibung
Product description

MODELS LIST

MODELS LIST		SUN2000-50K-MC0	SUN2000-40K-MC0	SUN2000-30K-MC0
INPUT	Maximum input voltage	1100V		
	Rated input voltage	600 V (380 V/400 V), 720 V (480 V)		
	Minimum startup voltage	180 V		
	MPPT voltage range	180–1000 V		
	Full-load MPPT voltage range	530–800 V (380 V/400 V), 625–850 V (480 V)	540–800 V (380 V/400 V), 625–850 V (440 V), 625–850 V (480 V)	500–800 V (380 V/400 V), 625–850 V (440 V), 625–850 V (480 V)
	Number of inputs	8		
	Number of MPPT circuits	4		
	Maximum input current (per PV string)	23 A		
	Maximum input current (per MPPT)	30 A/33 A/33 A/30 A	27 A	
	Maximum short-circuit current (per MPPT)	40 A/44 A/44 A/40 A	40 A	
OUTPUT	Rated output power	50 kW	40 kW	30 kW
	Maximum apparent power	55 kVA	44 kVA	33kVA
	Maximum active power (cosφ = 1)	55 kW	44 kW	33kW
	Rated output voltage	220 V/380 V, 230 V/400 V, 254 V/440 V, 265.5 V/460 V, 277 V/480 V, 3W+N+PE		
	Rated output current	76.0 A (380 V), 72.2 A (400 V), 60.1 A (480 V)	60.8 A (380 V), 57.7 A (400 V), 48.1 A (480 V)	45.6 A (380 V), 43.3 A (400 V), 36.1 A (480 V)
	Maximum output current	84.0 A (380 V), 79.8 A (400 V), 66.5 A (480 V)	67.2 A (380 V), 63.8 A (400 V), 53.2 A (480 V)	50.4 A (380 V), 47.9 A (400 V), 39.9 A (480 V)
	Supported power grid frequency	50 Hz/60 Hz		
Power factor	0.8 leading ~0.8lagging			
CONSTRUCTION	Inverter Topology	Non-isolated		
	Hardware [Version]	V800R025		
	Firmware [Version]	SUN2000MC V800R025C00		
	Type of NS Protection	Integrated		
	Protective Class	Class I		
	Overvoltage category	II (DC) / III (AC)		
	Enclosure Protection (IP)	IP66		

Prüfbericht-Nr.: CN25NMLN 001 <i>Test Report No.:</i>	Seite 8 von 11 <i>Page 8 of 11</i>
---	---------------------------------------

Produktbeschreibung <i>Product description</i>
--

Operating ambient temperature	-25°C to +60°C	
Pollution degree (PD)	III	
Dimensions (W x H x D)	640 mm x 530 mm x 270 mm	
Net weight (including hanging kits)	50 kg	45kg
Maximum operating altitude	4000 m (derated when the altitude is higher than 4000 m)	
Relative humidity	0%–100% RH	

Prüfbericht-Nr.: CN25NMLN 001
Test Report No.:

Seite 9 von 11
Page 9 of 11

Produktbeschreibung
Product description

2	Maße / Gewicht <i>Dimensions / Weight</i>	See models list
3	Bedienelemente <i>Operating elements</i>	N/A
4	Ausstattung / Zubehör <i>Equipment / Accessories</i>	N/A
5	Verwendete Materialien <i>Used materials</i>	N/A
6	Sonstiges <i>Other</i>	N/A

Prüfbericht-Nr.: CN25NMLN 001		Seite 10 von 11	
<i>Test Report No.:</i>		<i>Page 10 of 11</i>	
Absatz	Anforderungen - Prüfungen	Messergebnisse - Bemerkungen	Bewertung
<i>Clause</i>	<i>Requirements - Tests</i>	<i>Measuring results - Remarks</i>	<i>Evaluation</i>
1	<p>Anwendungsbereich</p> <p>Scope</p> <p>Details zur Ausgestaltung der messtechnischen Nachweise und zur Dokumentation der Messergebnisse sind in DIN VDE-V 0124-100 (VDE V 0124-100):2020-06 beschrieben.</p> <p><i>Details on the design of the measuring certificates and the documentation of the measurement results are described in DIN VDE-V 0124-100 (VDE V 0124-100):2020-06.</i></p>		

ANLAGE zum Prüfbericht-Nr.: CN25NMLN 001
APPENDIX to Test Report No.:

Seite 11 von 11
Page 11 of 11

ZUSATZ-DOKUMENTATION
ADDITIONAL DOCUMENTATION

List of Appendix :

- CN25NMLN 001 attachment 1–VDE V 0124-100: 2020 Test report (172 pages)
- CN25NMLN 001 attachment 2– Photo documentation (5 pages exculding cover page)

-End of test report-

Prüfbericht-Nr.: CN25NMLN 001 Attachment 1		Seite 1 von 172	
Test Report No.:		Page 1 of 172	
Absatz	Anforderungen - Prüfungen	Messergebnisse - Bemerkungen	Bewertung
Clause	Requirements - Tests	Measuring results - Remarks	Evaluation

DIN VDE V 0124-100/06.20			
1	Anwendungsbereich Scope		
	Diese DIN-VDE-Vornorm dient dem Nachweis der elektrischen Eigenschaften von Erzeugungseinheiten (EZE) nach der VDE-AR N 4105:2018-11 und gegebenenfalls anderen Netzanschlussbedingungen. <i>This DIN VDE preliminary standard serves to verify the electrical properties of power generation units (PGU) in accordance with VDE-AR N 4105:2018-11 and, if applicable, other grid connection conditions.</i>		
5	Prüfungen Tests		
5.1	Allgemeines General information		P
5.2	Nachweis zulässiger NetZRückwirkungen Verification of permitted network reaction		P
5.3	Nachweis des Symmetrieverhaltens von Umrichtern Verification of symmetry behaviour of inverter		P
5.4	Nachweis des Verhaltens der Erzeugungseinheit am Netz Verification of behaviours of PGU on grid		P
5.5	Nachweis des NA-Schutzes Verification of NS-protections		P
5.6	Zuschaltbedingungen und Synchronisierung Connection conditions and synchronuzation		P
5.7	Nachweis der PAV,E-überwachung Verification of PAV,E-monitoring		P
5.8	Nachweis der dynamischen Netzstützung Verification of dynamic network support		P

Prüfbericht-Nr.: CN25NMLN 001 Attachment 1
Test Report No.:

Seite 2 von 172
Page 2 of 172

ZUSATZ-DOKUMENTATION
ADDITIONAL DOCUMENTATION

See following pages for test data.

Prüfbericht-Nr.: CN25NMLN 001 Attachment 1
 Test report no.:

Seite 3 von 172
 Page 3 of 172

Test Engineer:	Kenny Mai	Reviewer:	Ann Zhang
Signature:	See cover page	Signature:	See cover page

Testing Location:	
Name:	See cover page
Address:	See cover page

Test Sample No.:	See cover page
------------------	----------------

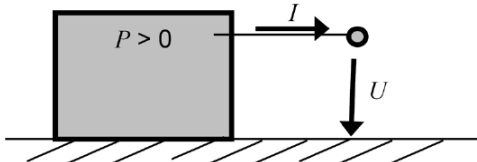
Test Condition:	Generator reference system applied in test: 
-----------------	---

Test Date:	See cover page
------------	----------------

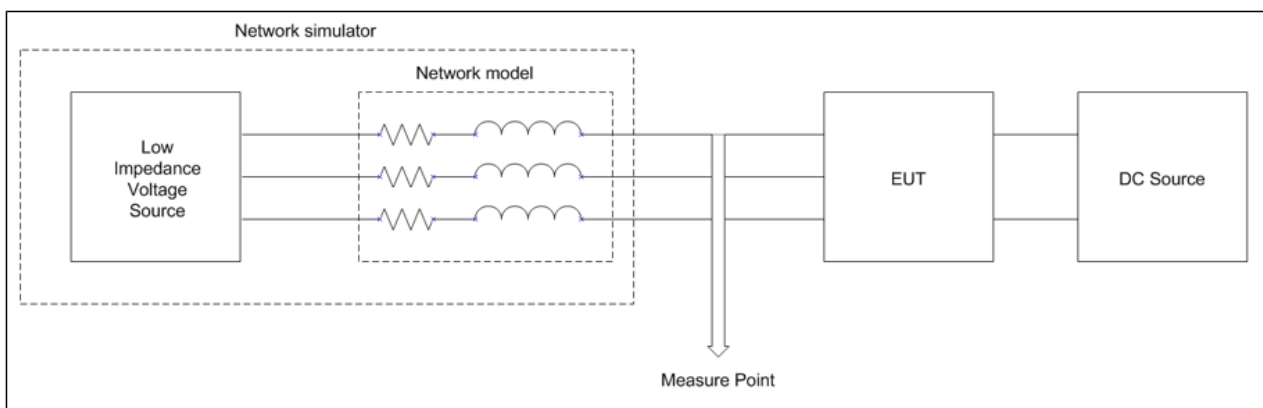
Test bench diagram:

A network model (grid impedance simulator) only connected in test bench in flicker test (<75A condition), in the other tests the network model is bypassed.

Prüfbericht-Nr.: CN25NMLN 001 Attachment 1
 Test report no.:

Seite 4 von 172
 Page 4 of 172

Test items	Remark
5.2 Verification of permitted network reaction	P
5.2.2 Rapid voltage change (Kimax)	P
5.2.3 Flicker	P
5.2.4 Harmonics and Inter-harmonics (I inter, I higher)	P
5.2.5 Commutation notches	N/A
5.2.6 DC current feeding to network (Idc)	P
5.3 Verification of symmetry behaviours of inverter	P
5.3.2 Tests of three-phase inverter (Imbalance)	P
5.3.3 Symmetry operation with a symmetry device	N/A
5.4 Verification of behaviours of PGU on network	P
5.4.2 Measurement of active- and reactive power ranges (P&Q range)	P
5.4.3 Active power reduction through setting provision (P control)	P
5.4.4 Active power output of PGU by over-frequency (LFSM-O)	P
5.4.5 Active power output of ESS by over-frequency (LFSM-O)	N/A
5.4.6 Active power output of PGU by under-frequency (LFSM-U)	P
5.4.7 Active power output of ESS by under-frequency (LFSM-U)	N/A
5.4.8.2 Tests of reactive power / displacement factor setting accuracy (Fixed $\cos\phi$)	P
5.4.8.3 Tests of displacement factor- / active power character curve ($\cos\phi(P)$)	P
5.4.8.4 Tests of reactive power-voltage character curve (Q(U))	P
5.5 Verification of NS-protection	P
5.5.2 NS-protection	P
5.5.3 Central NS-protecton	P
5.5.4 Integrated NS-protection	P
5.5.6 Interface switch (Functional safety)	P
5.5.7 Protection devices and protection settings (OV/UV, OF/UF)	P
5.5.9 Constructional features of NS protection	P
5.5.10 Islanding detection	P
5.6 Connection conditions and synchronization (Reconnection)	P
5.7 Verification of $P_{AV,E}$ monitoring	P
5.8 Verification of dynamic network supporting (FVRT)	P

5.2.2	TABLE: Rapid voltage change (Kimax)			P
Test Conditions	Measurements			Limit
	U [V]	I [A]	Ki	Ki
Starting to 50%Pn	230.15	2.19	0.03	≤ 1.2
Starting to 100% Pn	230.12	2.11	0.03	≤ 1.2
Stopping at 100% Pn	230.94	72.92	1.01	≤ 1.2
Note(s):				

5.2.3	TABLE: Flicker						P	
SUN2000-50K-MC0								
L1								
Test Condition	Measurement							
	30°		50°		70°		85°	
P/Pn [%]	Pst	C _{ψk}	Pst	C _{ψk}	Pst	C _{ψk}	Pst	C _{ψk}
10	0.005	0.075	0.006	0.090	0.008	0.120	0.008	0.120
20	0.028	0.420	0.021	0.315	0.013	0.195	0.009	0.135
30	0.028	0.420	0.022	0.330	0.014	0.210	0.010	0.150
40	0.029	0.435	0.023	0.345	0.016	0.240	0.014	0.210
50	0.027	0.405	0.021	0.315	0.014	0.210	0.011	0.165
60	0.027	0.405	0.020	0.300	0.013	0.195	0.010	0.150
70	0.027	0.405	0.021	0.315	0.013	0.195	0.010	0.150
80	0.029	0.435	0.022	0.330	0.014	0.210	0.010	0.150
90	0.024	0.360	0.019	0.285	0.013	0.195	0.010	0.150
100	0.022	0.330	0.017	0.255	0.014	0.210	0.014	0.210
100	0.024	0.360	0.019	0.285	0.015	0.225	0.013	0.195
100	0.012	0.180	0.016	0.240	0.018	0.270	0.018	0.270
L2								
Test Condition	Measurement							
	30°		50°		70°		85°	
P/Pn [%]	Pst	C _{ψk}	Pst	C _{ψk}	Pst	C _{ψk}	Pst	C _{ψk}
10	0.005	0.075	0.006	0.090	0.007	0.105	0.008	0.120
20	0.029	0.435	0.021	0.315	0.012	0.180	0.011	0.165
30	0.029	0.435	0.022	0.330	0.013	0.195	0.009	0.135
40	0.029	0.435	0.023	0.345	0.016	0.240	0.015	0.225
50	0.027	0.405	0.022	0.330	0.014	0.210	0.011	0.165
60	0.026	0.390	0.020	0.300	0.014	0.210	0.011	0.165
70	0.027	0.405	0.020	0.300	0.014	0.210	0.009	0.135
80	0.028	0.420	0.022	0.330	0.014	0.210	0.009	0.135
90	0.024	0.360	0.019	0.285	0.012	0.180	0.011	0.165
100	0.022	0.330	0.018	0.270	0.015	0.225	0.015	0.225
100	0.024	0.360	0.019	0.285	0.015	0.225	0.013	0.195
100	0.012	0.180	0.015	0.225	0.018	0.270	0.018	0.270

L3								
Test Condition	Measurement							
	30°		50°		70°		85°	
P/Pn [%]	Pst	C _{ψk}	Pst	C _{ψk}	Pst	C _{ψk}	Pst	C _{ψk}
10	0.005	0.075	0.006	0.090	0.007	0.105	0.008	0.120
20	0.029	0.435	0.022	0.330	0.013	0.195	0.008	0.120
30	0.028	0.420	0.022	0.330	0.013	0.195	0.009	0.135
40	0.029	0.435	0.023	0.345	0.016	0.240	0.014	0.210
50	0.027	0.405	0.021	0.315	0.015	0.225	0.011	0.165
60	0.027	0.405	0.020	0.300	0.014	0.210	0.011	0.165
70	0.027	0.405	0.021	0.315	0.014	0.210	0.010	0.150
80	0.028	0.420	0.022	0.330	0.014	0.210	0.011	0.165
90	0.024	0.360	0.019	0.285	0.013	0.195	0.010	0.150
100	0.021	0.315	0.018	0.270	0.015	0.225	0.014	0.210
100	0.024	0.360	0.020	0.300	0.015	0.225	0.013	0.195
100	0.012	0.180	0.016	0.240	0.018	0.270	0.018	0.270
Note(s):								

5.2.3	TABLE: Flicker						P	
SUN2000-30K-MC0								
L1								
Test Condition	Measurement							
	30°		50°		70°		85°	
P/Pn [%]	Pst	C _{ψk}	Pst	C _{ψk}	Pst	C _{ψk}	Pst	C _{ψk}
10	0.005	0.075	0.006	0.090	0.008	0.120	0.008	0.120
20	0.017	0.255	0.013	0.195	0.009	0.135	0.007	0.105
30	0.015	0.225	0.012	0.180	0.011	0.165	0.011	0.165
40	0.017	0.255	0.014	0.210	0.012	0.180	0.010	0.150
50	0.017	0.255	0.014	0.210	0.010	0.150	0.009	0.135
60	0.015	0.225	0.012	0.180	0.009	0.135	0.007	0.105
70	0.013	0.195	0.011	0.165	0.010	0.150	0.010	0.150
80	0.013	0.195	0.011	0.165	0.010	0.150	0.010	0.150
90	0.014	0.210	0.012	0.180	0.010	0.150	0.009	0.135
100	0.013	0.195	0.011	0.165	0.010	0.150	0.010	0.150
100	0.014	0.210	0.012	0.180	0.009	0.135	0.008	0.120
100	0.006	0.090	0.007	0.105	0.008	0.120	0.008	0.120
L2								
Test Condition	Measurement							
	30°		50°		70°		85°	
P/Pn [%]	Pst	C _{ψk}	Pst	C _{ψk}	Pst	C _{ψk}	Pst	C _{ψk}
10	0.004	0.060	0.006	0.090	0.007	0.105	0.008	0.120
20	0.017	0.255	0.013	0.195	0.009	0.135	0.007	0.105
30	0.015	0.225	0.012	0.180	0.011	0.165	0.010	0.150

40	0.017	0.255	0.014	0.210	0.011	0.165	0.010	0.150
50	0.016	0.240	0.013	0.195	0.011	0.165	0.009	0.135
60	0.015	0.225	0.012	0.180	0.009	0.135	0.007	0.105
70	0.013	0.195	0.011	0.165	0.009	0.135	0.008	0.120
80	0.013	0.195	0.011	0.165	0.009	0.135	0.009	0.135
90	0.014	0.210	0.011	0.165	0.009	0.135	0.008	0.120
100	0.013	0.195	0.011	0.165	0.010	0.150	0.009	0.135
100	0.014	0.210	0.012	0.180	0.009	0.135	0.008	0.120
100	0.006	0.090	0.007	0.105	0.008	0.120	0.008	0.120

L3

Test Condition	Measurement							
	30°		50°		70°		85°	
P/Pn [%]	Pst	C _{ψ_k}	Pst	C _{ψ_k}	Pst	C _{ψ_k}	Pst	C _{ψ_k}
10	0.005	0.075	0.006	0.090	0.008	0.120	0.008	0.120
20	0.017	0.255	0.013	0.195	0.009	0.135	0.007	0.105
30	0.015	0.225	0.012	0.180	0.010	0.150	0.008	0.120
40	0.016	0.240	0.014	0.210	0.011	0.165	0.009	0.135
50	0.017	0.255	0.013	0.195	0.010	0.150	0.009	0.135
60	0.016	0.240	0.012	0.180	0.009	0.135	0.007	0.105
70	0.013	0.195	0.011	0.165	0.010	0.150	0.010	0.150
80	0.013	0.195	0.011	0.165	0.010	0.150	0.009	0.135
90	0.014	0.210	0.011	0.165	0.009	0.135	0.008	0.120
100	0.013	0.195	0.012	0.180	0.011	0.165	0.012	0.180
100	0.015	0.225	0.012	0.180	0.010	0.150	0.009	0.135
100	0.006	0.090	0.007	0.105	0.008	0.120	0.009	0.135

Note(s):

5.2.4	TABLE: linter & lhigher											P
SUN2000-50K-MC0												
Harmonics												
P/P _n [%]	0	10	20	30	40	50	60	70	80	90	100	Limit
Order No.	I/In [%]											
2	0.100	0.107	0.150	0.150	0.163	0.175	0.213	0.192	0.236	0.228	0.236	--
3	0.020	0.043	0.040	0.038	0.040	0.041	0.049	0.055	0.068	0.085	0.101	--
4	0.372	0.028	0.032	0.039	0.088	0.046	0.067	0.067	0.084	0.082	0.074	--
5	0.267	0.019	0.050	0.059	0.074	0.083	0.100	0.147	0.165	0.175	0.175	--
6	0.040	0.019	0.025	0.054	0.043	0.064	0.073	0.078	0.096	0.095	0.072	--
7	0.098	0.148	0.136	0.139	0.139	0.129	0.116	0.120	0.121	0.110	0.103	--
8	0.085	0.018	0.027	0.034	0.042	0.038	0.051	0.055	0.058	0.050	0.055	--
9	0.052	0.040	0.049	0.058	0.073	0.052	0.060	0.053	0.057	0.041	0.033	--
10	0.045	0.022	0.026	0.016	0.036	0.017	0.019	0.037	0.031	0.028	0.033	--
11	0.329	0.256	0.290	0.243	0.225	0.236	0.256	0.282	0.290	0.303	0.305	--
12	0.017	0.016	0.025	0.035	0.030	0.028	0.028	0.029	0.031	0.033	0.032	--
13	0.092	0.147	0.331	0.466	0.559	0.629	0.645	0.636	0.615	0.562	0.500	--
14	0.036	0.029	0.021	0.017	0.027	0.035	0.053	0.051	0.047	0.043	0.056	--
15	0.030	0.041	0.028	0.047	0.054	0.051	0.058	0.060	0.060	0.064	0.052	--
16	0.038	0.017	0.019	0.010	0.026	0.013	0.017	0.020	0.019	0.025	0.014	--
17	0.115	0.154	0.247	0.310	0.290	0.261	0.223	0.212	0.174	0.164	0.169	--
18	0.017	0.016	0.009	0.016	0.018	0.021	0.030	0.030	0.022	0.022	0.021	--
19	0.241	0.075	0.091	0.132	0.258	0.347	0.403	0.417	0.435	0.415	0.363	--
20	0.025	0.025	0.011	0.012	0.013	0.011	0.028	0.020	0.031	0.023	0.032	--
21	0.010	0.021	0.019	0.032	0.018	0.022	0.031	0.031	0.040	0.042	0.040	--
22	0.032	0.018	0.023	0.016	0.019	0.019	0.020	0.013	0.018	0.025	0.018	--
23	0.044	0.079	0.043	0.166	0.241	0.254	0.232	0.209	0.157	0.129	0.129	--
24	0.014	0.017	0.022	0.008	0.021	0.010	0.012	0.017	0.027	0.029	0.025	--
25	0.210	0.049	0.047	0.058	0.050	0.115	0.185	0.217	0.260	0.277	0.278	--
26	0.015	0.019	0.029	0.019	0.026	0.015	0.018	0.019	0.015	0.016	0.022	--
27	0.011	0.013	0.016	0.010	0.018	0.013	0.019	0.018	0.035	0.021	0.025	--
28	0.023	0.023	0.011	0.022	0.020	0.023	0.022	0.010	0.012	0.017	0.011	--
29	0.077	0.049	0.053	0.030	0.125	0.177	0.199	0.183	0.153	0.115	0.110	--
30	0.019	0.013	0.017	0.011	0.016	0.013	0.008	0.017	0.019	0.025	0.026	--
31	0.112	0.024	0.054	0.029	0.013	0.014	0.053	0.089	0.125	0.176	0.199	--
32	0.015	0.015	0.015	0.018	0.023	0.017	0.030	0.021	0.012	0.025	0.022	--
33	0.006	0.035	0.008	0.017	0.013	0.011	0.008	0.007	0.017	0.022	0.012	--
34	0.012	0.014	0.017	0.017	0.013	0.014	0.019	0.014	0.009	0.012	0.010	--
35	0.089	0.059	0.035	0.044	0.022	0.072	0.125	0.126	0.115	0.081	0.080	--
36	0.006	0.011	0.016	0.021	0.017	0.011	0.009	0.014	0.015	0.014	0.021	--
37	0.030	0.070	0.045	0.043	0.040	0.011	0.016	0.015	0.037	0.087	0.130	--
38	0.012	0.021	0.020	0.015	0.011	0.013	0.025	0.015	0.017	0.024	0.015	--
39	0.011	0.014	0.014	0.011	0.019	0.017	0.017	0.012	0.020	0.017	0.011	--
40	0.014	0.013	0.012	0.008	0.010	0.004	0.021	0.018	0.016	0.011	0.007	--

Inter-harmonics												
P/Pn [%]	0	10	20	30	40	50	60	70	80	90	100	Limit
f [Hz]	I/In [%]											
75	0.022	0.032	0.036	0.033	0.039	0.037	0.043	0.046	0.053	0.054	0.058	--
125	0.017	0.037	0.055	0.044	0.058	0.038	0.051	0.051	0.052	0.054	0.051	--
175	0.014	0.038	0.047	0.041	0.053	0.035	0.047	0.047	0.049	0.048	0.045	--
225	0.014	0.035	0.040	0.033	0.041	0.028	0.039	0.044	0.044	0.042	0.053	--
275	0.013	0.024	0.027	0.024	0.030	0.019	0.025	0.024	0.023	0.023	0.023	--
325	0.015	0.034	0.036	0.029	0.039	0.027	0.032	0.033	0.034	0.033	0.036	--
375	0.015	0.021	0.022	0.018	0.023	0.016	0.019	0.021	0.020	0.020	0.019	--
425	0.014	0.024	0.026	0.022	0.027	0.018	0.021	0.022	0.022	0.023	0.022	--
475	0.014	0.024	0.027	0.022	0.026	0.017	0.020	0.021	0.022	0.021	0.022	--
525	0.015	0.024	0.026	0.020	0.025	0.017	0.021	0.022	0.022	0.024	0.022	--
575	0.014	0.022	0.024	0.019	0.023	0.015	0.019	0.019	0.021	0.019	0.018	--
625	0.015	0.020	0.022	0.018	0.022	0.015	0.018	0.018	0.019	0.017	0.018	--
675	0.014	0.020	0.021	0.017	0.020	0.014	0.017	0.018	0.019	0.017	0.017	--
725	0.012	0.020	0.020	0.017	0.020	0.014	0.017	0.017	0.017	0.017	0.017	--
775	0.012	0.018	0.019	0.016	0.020	0.013	0.016	0.016	0.016	0.016	0.017	--
825	0.016	0.016	0.018	0.015	0.019	0.013	0.016	0.017	0.017	0.017	0.017	--
875	0.012	0.016	0.016	0.014	0.017	0.012	0.015	0.015	0.016	0.015	0.016	--
925	0.011	0.015	0.016	0.014	0.017	0.011	0.014	0.014	0.015	0.014	0.015	--
975	0.010	0.015	0.015	0.013	0.016	0.010	0.013	0.014	0.014	0.014	0.015	--
1025	0.010	0.014	0.015	0.012	0.015	0.010	0.013	0.014	0.014	0.013	0.014	--
1075	0.009	0.014	0.015	0.012	0.015	0.010	0.013	0.013	0.013	0.013	0.013	--
1125	0.009	0.013	0.014	0.011	0.014	0.010	0.012	0.012	0.013	0.013	0.013	--
1175	0.009	0.013	0.013	0.011	0.013	0.009	0.011	0.012	0.012	0.012	0.012	--
1225	0.009	0.013	0.012	0.010	0.013	0.009	0.011	0.012	0.012	0.012	0.012	--
1275	0.008	0.012	0.013	0.010	0.013	0.009	0.011	0.011	0.011	0.011	0.012	--
1325	0.008	0.012	0.012	0.010	0.012	0.008	0.010	0.012	0.012	0.011	0.011	--
1375	0.008	0.011	0.012	0.009	0.012	0.008	0.010	0.011	0.011	0.011	0.011	--
1425	0.008	0.012	0.011	0.009	0.012	0.008	0.010	0.011	0.011	0.011	0.010	--
1475	0.008	0.011	0.011	0.009	0.011	0.008	0.010	0.010	0.010	0.011	0.011	--
1525	0.008	0.011	0.011	0.009	0.011	0.007	0.010	0.011	0.010	0.011	0.011	--
1575	0.008	0.012	0.011	0.009	0.011	0.007	0.010	0.010	0.010	0.011	0.010	--
1625	0.008	0.011	0.011	0.009	0.011	0.007	0.009	0.011	0.010	0.013	0.010	--
1675	0.007	0.010	0.011	0.009	0.012	0.009	0.011	0.013	0.011	0.010	0.009	--
1725	0.007	0.010	0.010	0.008	0.011	0.007	0.009	0.010	0.010	0.010	0.009	--
1775	0.007	0.011	0.010	0.008	0.011	0.007	0.009	0.010	0.009	0.010	0.009	--
1825	0.007	0.011	0.010	0.008	0.010	0.007	0.009	0.010	0.009	0.010	0.009	--
1875	0.008	0.011	0.010	0.008	0.011	0.006	0.009	0.010	0.009	0.009	0.009	--
1925	0.007	0.011	0.010	0.008	0.011	0.006	0.008	0.010	0.009	0.010	0.009	--
1975	0.008	0.011	0.010	0.008	0.011	0.006	0.008	0.010	0.009	0.010	0.009	--

Prüfbericht-Nr.: CN25NMLN 001 Attachment 1	Seite 10 von 172
<i>Test report no.:</i>	<i>Page 10 of 172</i>

Higher frequency Harmonics												
P/P _n [%]	0	10	20	30	40	50	60	70	80	90	100	Limit
f [kHz]	I/In [%]											
2.1	0.095	0.116	0.097	0.035	0.058	0.030	0.052	0.083	0.092	0.085	0.100	--
2.3	0.038	0.077	0.085	0.046	0.044	0.060	0.047	0.039	0.066	0.080	0.043	--
2.5	0.060	0.079	0.055	0.091	0.046	0.049	0.044	0.043	0.046	0.032	0.050	--
2.7	0.059	0.089	0.092	0.091	0.099	0.066	0.109	0.075	0.058	0.096	0.072	--
2.9	0.033	0.060	0.072	0.088	0.049	0.047	0.079	0.080	0.076	0.067	0.103	--
3.1	0.048	0.066	0.063	0.061	0.077	0.079	0.041	0.062	0.040	0.069	0.067	--
3.3	0.059	0.055	0.068	0.057	0.089	0.080	0.073	0.060	0.114	0.074	0.115	--
3.5	0.050	0.048	0.044	0.053	0.064	0.052	0.045	0.058	0.068	0.081	0.097	--
3.7	0.025	0.043	0.046	0.048	0.043	0.029	0.072	0.037	0.057	0.050	0.063	--
3.9	0.038	0.042	0.042	0.047	0.029	0.064	0.051	0.067	0.045	0.091	0.071	--
4.1	0.016	0.034	0.026	0.039	0.040	0.029	0.042	0.046	0.057	0.065	0.044	--
4.3	0.023	0.031	0.036	0.020	0.031	0.050	0.025	0.047	0.035	0.061	0.065	--
4.5	0.024	0.037	0.029	0.031	0.033	0.042	0.051	0.033	0.069	0.069	0.058	--
4.7	0.019	0.018	0.020	0.017	0.019	0.041	0.020	0.030	0.048	0.029	0.055	--
4.9	0.014	0.020	0.020	0.017	0.018	0.016	0.038	0.025	0.035	0.052	0.037	--
5.1	0.014	0.020	0.017	0.020	0.022	0.029	0.026	0.030	0.032	0.043	0.052	--
5.3	0.009	0.017	0.012	0.014	0.012	0.010	0.023	0.020	0.019	0.038	0.041	--
5.5	0.014	0.013	0.012	0.009	0.012	0.013	0.014	0.020	0.019	0.016	0.027	--
5.7	0.016	0.009	0.010	0.012	0.012	0.014	0.016	0.014	0.021	0.028	0.027	--
5.9	0.011	0.010	0.006	0.005	0.008	0.011	0.008	0.012	0.014	0.016	0.020	--
6.1	0.008	0.006	0.006	0.006	0.009	0.007	0.009	0.008	0.009	0.014	0.018	--
6.3	0.009	0.004	0.006	0.007	0.007	0.007	0.007	0.008	0.008	0.011	0.013	--
6.5	0.006	0.004	0.004	0.004	0.005	0.005	0.005	0.005	0.005	0.006	0.009	--
6.7	0.003	0.003	0.003	0.004	0.004	0.004	0.003	0.005	0.004	0.007	0.008	--
6.9	0.003	0.003	0.003	0.003	0.003	0.003	0.003	0.003	0.003	0.005	0.006	--
7.1	0.001	0.002	0.002	0.002	0.002	0.002	0.002	0.003	0.003	0.003	0.005	--
7.3	0.002	0.002	0.002	0.002	0.002	0.002	0.002	0.003	0.003	0.003	0.004	--
7.5	0.002	0.001	0.002	0.001	0.001	0.001	0.001	0.002	0.001	0.002	0.003	--
7.7	0.001	0.001	0.001	0.001	0.001	0.001	0.001	0.001	0.001	0.001	0.002	--
7.9	0.001	0.001	0.001	0.001	0.001	0.001	0.001	0.001	0.001	0.001	0.001	--
8.1	0.001	0.001	0.001	0.001	0.001	0.001	0.001	0.001	0.001	0.001	0.001	--
8.3	0.001	0.001	0.000	0.000	0.000	0.000	0.000	0.001	0.001	0.001	0.001	--
8.5	0.001	0.000	0.000	0.000	0.000	0.000	0.000	0.001	0.001	0.001	0.001	--
8.7	0.001	0.000	0.001	0.001	0.001	0.001	0.001	0.001	0.001	0.001	0.001	--
8.9	0.001	0.001	0.000	0.000	0.000	0.000	0.000	0.000	0.001	0.001	0.001	--

Note(s): The max. value of three phases were chosen.

5.2.4	TABLE: linter & lhigher											P
SUN2000-30K-MC0												
Harmonics												
P/P _n [%]	0	10	20	30	40	50	60	70	80	90	100	Limit
Order No.	I/In [%]											
2	0.167	0.146	0.168	0.223	0.218	0.199	0.264	0.198	0.216	0.228	0.305	--
3	0.033	0.068	0.042	0.039	0.040	0.048	0.048	0.049	0.054	0.057	0.065	--
4	0.622	0.055	0.071	0.041	0.079	0.056	0.078	0.150	0.082	0.103	0.065	--
5	0.446	0.075	0.043	0.070	0.075	0.094	0.110	0.133	0.146	0.135	0.181	--
6	0.067	0.044	0.039	0.052	0.050	0.092	0.056	0.096	0.096	0.116	0.104	--
7	0.165	0.272	0.218	0.219	0.229	0.230	0.231	0.231	0.220	0.217	0.212	--
8	0.142	0.023	0.028	0.030	0.043	0.041	0.048	0.079	0.061	0.063	0.078	--
9	0.086	0.069	0.068	0.083	0.101	0.086	0.096	0.104	0.096	0.098	0.102	--
10	0.075	0.023	0.047	0.027	0.022	0.018	0.037	0.065	0.034	0.052	0.040	--
11	0.550	0.673	0.476	0.529	0.499	0.404	0.347	0.370	0.358	0.403	0.443	--
12	0.029	0.027	0.031	0.044	0.041	0.059	0.031	0.046	0.039	0.048	0.048	--
13	0.154	0.398	0.230	0.502	0.670	0.768	0.886	0.961	0.991	1.057	1.174	--
14	0.059	0.061	0.034	0.035	0.022	0.020	0.035	0.079	0.053	0.062	0.066	--
15	0.049	0.063	0.063	0.037	0.033	0.070	0.062	0.083	0.078	0.087	0.082	--
16	0.064	0.046	0.032	0.030	0.029	0.022	0.043	0.024	0.022	0.025	0.044	--
17	0.194	0.145	0.277	0.382	0.483	0.511	0.476	0.479	0.408	0.413	0.367	--
18	0.028	0.027	0.020	0.024	0.016	0.033	0.018	0.035	0.034	0.045	0.041	--
19	0.402	0.222	0.163	0.143	0.146	0.225	0.362	0.464	0.556	0.614	0.715	--
20	0.041	0.041	0.043	0.024	0.025	0.018	0.047	0.031	0.026	0.036	0.024	--
21	0.017	0.062	0.033	0.026	0.031	0.045	0.020	0.037	0.034	0.051	0.041	--
22	0.053	0.031	0.031	0.038	0.014	0.029	0.030	0.020	0.025	0.021	0.041	--
23	0.074	0.129	0.044	0.034	0.155	0.279	0.373	0.412	0.406	0.411	0.389	--
24	0.023	0.037	0.034	0.019	0.018	0.012	0.027	0.015	0.019	0.017	0.017	--
25	0.349	0.084	0.094	0.052	0.096	0.088	0.051	0.113	0.188	0.233	0.305	--
26	0.025	0.028	0.020	0.026	0.016	0.025	0.042	0.024	0.029	0.032	0.040	--
27	0.018	0.056	0.038	0.038	0.029	0.013	0.024	0.026	0.017	0.027	0.031	--
28	0.038	0.018	0.038	0.017	0.023	0.028	0.026	0.023	0.037	0.027	0.025	--
29	0.128	0.164	0.067	0.081	0.084	0.051	0.161	0.236	0.286	0.316	0.338	--
30	0.032	0.018	0.022	0.023	0.035	0.022	0.035	0.020	0.016	0.017	0.012	--
31	0.187	0.143	0.071	0.106	0.077	0.049	0.018	0.020	0.024	0.044	0.075	--
32	0.025	0.029	0.018	0.024	0.012	0.029	0.039	0.022	0.028	0.030	0.045	--
33	0.010	0.021	0.042	0.012	0.027	0.028	0.022	0.015	0.024	0.015	0.013	--
34	0.019	0.037	0.022	0.020	0.017	0.024	0.018	0.017	0.026	0.022	0.023	--
35	0.149	0.141	0.069	0.076	0.052	0.074	0.024	0.058	0.125	0.161	0.212	--
36	0.010	0.019	0.019	0.018	0.016	0.032	0.037	0.024	0.015	0.017	0.010	--
37	0.051	0.091	0.114	0.081	0.058	0.075	0.068	0.052	0.018	0.020	0.030	--
38	0.020	0.055	0.023	0.023	0.022	0.024	0.022	0.021	0.024	0.024	0.021	--
39	0.019	0.063	0.033	0.042	0.020	0.016	0.017	0.033	0.034	0.028	0.031	--
40	0.023	0.037	0.030	0.018	0.017	0.016	0.036	0.013	0.009	0.016	0.032	--

Inter-harmonics												
P/Pn [%]	0	10	20	30	40	50	60	70	80	90	100	Limit
f [Hz]	I/In [%]											
75	0.038	0.048	0.065	0.060	0.056	0.055	0.065	0.060	0.060	0.068	0.072	--
125	0.029	0.060	0.086	0.083	0.075	0.075	0.088	0.080	0.067	0.085	0.080	--
175	0.024	0.060	0.084	0.075	0.071	0.069	0.088	0.070	0.061	0.075	0.071	--
225	0.024	0.063	0.070	0.060	0.059	0.051	0.073	0.066	0.051	0.074	0.064	--
275	0.021	0.041	0.055	0.046	0.042	0.039	0.050	0.043	0.034	0.044	0.040	--
325	0.026	0.063	0.084	0.063	0.056	0.050	0.071	0.058	0.045	0.059	0.054	--
375	0.026	0.036	0.043	0.036	0.031	0.029	0.040	0.033	0.027	0.034	0.034	--
425	0.024	0.042	0.049	0.041	0.037	0.036	0.044	0.039	0.029	0.039	0.036	--
475	0.024	0.044	0.049	0.043	0.039	0.035	0.045	0.038	0.029	0.037	0.035	--
525	0.025	0.047	0.046	0.040	0.037	0.034	0.044	0.035	0.030	0.035	0.036	--
575	0.024	0.042	0.045	0.037	0.034	0.031	0.039	0.033	0.026	0.034	0.032	--
625	0.025	0.042	0.043	0.037	0.032	0.029	0.037	0.031	0.026	0.032	0.030	--
675	0.023	0.038	0.040	0.032	0.030	0.028	0.037	0.029	0.025	0.031	0.028	--
725	0.020	0.035	0.038	0.033	0.029	0.026	0.035	0.030	0.023	0.031	0.028	--
775	0.020	0.032	0.035	0.031	0.028	0.026	0.034	0.028	0.023	0.030	0.027	--
825	0.027	0.030	0.033	0.029	0.027	0.024	0.034	0.027	0.023	0.026	0.027	--
875	0.019	0.030	0.030	0.028	0.025	0.022	0.030	0.025	0.020	0.026	0.025	--
925	0.019	0.027	0.031	0.027	0.025	0.022	0.028	0.024	0.019	0.025	0.023	--
975	0.016	0.026	0.028	0.025	0.022	0.021	0.028	0.023	0.018	0.023	0.021	--
1025	0.017	0.023	0.027	0.024	0.022	0.019	0.027	0.022	0.018	0.023	0.022	--
1075	0.015	0.022	0.027	0.024	0.021	0.019	0.026	0.020	0.018	0.023	0.022	--
1125	0.016	0.021	0.027	0.023	0.020	0.019	0.025	0.020	0.016	0.020	0.020	--
1175	0.015	0.021	0.025	0.021	0.018	0.017	0.024	0.019	0.016	0.020	0.019	--
1225	0.015	0.021	0.026	0.020	0.018	0.017	0.023	0.018	0.016	0.020	0.019	--
1275	0.014	0.019	0.026	0.021	0.017	0.016	0.023	0.018	0.015	0.018	0.019	--
1325	0.014	0.019	0.025	0.020	0.017	0.016	0.021	0.017	0.015	0.018	0.018	--
1375	0.013	0.020	0.024	0.019	0.017	0.015	0.021	0.016	0.014	0.018	0.017	--
1425	0.013	0.022	0.023	0.019	0.016	0.015	0.020	0.017	0.013	0.018	0.017	--
1475	0.013	0.020	0.022	0.018	0.016	0.014	0.018	0.016	0.013	0.016	0.016	--
1525	0.013	0.021	0.022	0.018	0.016	0.014	0.019	0.016	0.013	0.017	0.016	--
1575	0.014	0.020	0.022	0.017	0.015	0.014	0.019	0.015	0.013	0.017	0.016	--
1625	0.013	0.020	0.022	0.017	0.015	0.014	0.018	0.015	0.012	0.015	0.015	--
1675	0.013	0.020	0.022	0.018	0.015	0.013	0.017	0.015	0.012	0.016	0.014	--
1725	0.012	0.022	0.022	0.017	0.014	0.013	0.018	0.015	0.012	0.016	0.015	--
1775	0.012	0.021	0.020	0.016	0.014	0.013	0.017	0.015	0.011	0.015	0.014	--
1825	0.012	0.020	0.024	0.017	0.014	0.013	0.017	0.015	0.011	0.015	0.014	--
1875	0.014	0.020	0.022	0.017	0.014	0.012	0.017	0.015	0.011	0.016	0.014	--
1925	0.012	0.020	0.022	0.018	0.013	0.012	0.018	0.015	0.011	0.016	0.013	--
1975	0.013	0.019	0.023	0.017	0.016	0.012	0.017	0.016	0.011	0.015	0.014	--

Higher frequency Harmonics												
P/P _n [%]	0	10	20	30	40	50	60	70	80	90	100	Limit
f [kHz]	I/In [%]											
2.1	0.158	0.176	0.185	0.178	0.157	0.057	0.101	0.094	0.051	0.056	0.098	--
2.3	0.063	0.182	0.104	0.170	0.122	0.082	0.078	0.076	0.101	0.090	0.073	--
2.5	0.099	0.087	0.148	0.124	0.123	0.157	0.088	0.090	0.084	0.083	0.072	--
2.7	0.098	0.134	0.152	0.144	0.199	0.155	0.177	0.148	0.100	0.127	0.184	--
2.9	0.056	0.094	0.110	0.130	0.079	0.144	0.137	0.058	0.078	0.105	0.129	--
3.1	0.080	0.087	0.101	0.106	0.100	0.102	0.083	0.138	0.132	0.093	0.067	--
3.3	0.098	0.110	0.111	0.102	0.139	0.099	0.156	0.141	0.132	0.145	0.119	--
3.5	0.083	0.060	0.092	0.082	0.066	0.090	0.066	0.118	0.092	0.060	0.082	--
3.7	0.038	0.111	0.070	0.077	0.080	0.085	0.073	0.065	0.049	0.094	0.131	--
3.9	0.067	0.103	0.086	0.072	0.089	0.083	0.075	0.064	0.101	0.097	0.100	--
4.1	0.027	0.074	0.067	0.040	0.043	0.064	0.056	0.066	0.041	0.073	0.076	--
4.3	0.039	0.049	0.055	0.059	0.042	0.034	0.066	0.039	0.078	0.074	0.043	--
4.5	0.040	0.058	0.042	0.045	0.052	0.052	0.039	0.069	0.067	0.069	0.087	--
4.7	0.035	0.037	0.038	0.037	0.037	0.032	0.038	0.036	0.066	0.054	0.043	--
4.9	0.018	0.037	0.046	0.030	0.033	0.028	0.045	0.033	0.036	0.040	0.062	--
5.1	0.023	0.030	0.032	0.026	0.032	0.034	0.033	0.030	0.044	0.054	0.041	--
5.3	0.016	0.024	0.029	0.022	0.016	0.023	0.025	0.023	0.020	0.029	0.039	--
5.5	0.024	0.028	0.028	0.019	0.014	0.015	0.018	0.020	0.028	0.026	0.021	--
5.7	0.026	0.024	0.022	0.015	0.018	0.020	0.020	0.015	0.023	0.021	0.026	--
5.9	0.018	0.014	0.014	0.011	0.012	0.009	0.015	0.013	0.021	0.019	0.014	--
6.1	0.012	0.012	0.012	0.011	0.011	0.010	0.013	0.015	0.014	0.014	0.015	--
6.3	0.014	0.008	0.010	0.009	0.009	0.012	0.013	0.013	0.014	0.013	0.011	--
6.5	0.012	0.007	0.006	0.006	0.008	0.006	0.007	0.009	0.009	0.008	0.008	--
6.7	0.007	0.005	0.006	0.005	0.005	0.006	0.006	0.007	0.008	0.005	0.005	--
6.9	0.005	0.004	0.005	0.004	0.004	0.005	0.006	0.007	0.007	0.005	0.005	--
7.1	0.002	0.004	0.004	0.004	0.004	0.006	0.007	0.007	0.008	0.006	0.003	--
7.3	0.003	0.003	0.003	0.004	0.006	0.005	0.003	0.003	0.004	0.006	0.004	--
7.5	0.003	0.002	0.002	0.005	0.003	0.002	0.002	0.002	0.002	0.002	0.004	--
7.7	0.002	0.001	0.001	0.002	0.002	0.001	0.001	0.001	0.001	0.002	0.003	--
7.9	0.002	0.001	0.002	0.001	0.001	0.001	0.001	0.001	0.001	0.001	0.002	--
8.1	0.002	0.001	0.002	0.001	0.001	0.001	0.001	0.001	0.001	0.001	0.001	--
8.3	0.001	0.001	0.001	0.001	0.001	0.001	0.001	0.001	0.001	0.001	0.001	--
8.5	0.001	0.001	0.001	0.001	0.001	0.001	0.001	0.001	0.001	0.001	0.001	--
8.7	0.001	0.001	0.001	0.001	0.001	0.001	0.001	0.001	0.001	0.001	0.001	--
8.9	0.001	0.001	0.001	0.001	0.001	0.000	0.001	0.001	0.001	0.001	0.001	--

Note(s): The max. value of three phases were chosen.

5.2.6	TABLE: DC current feeding to network (Idc)						P
SUN2000-50K-MCO							
Test Conditions P/ P _{E_{max}}	Measurements						Limit
	Idc / In [%]						Idc/In
	L1	L2	L3				
30% - 40%	0.023	0.110	0.030				0.5%
60% - 70%	0.020	0.108	0.031				0.5%
> 95%	0.017	0.112	0.026				0.5%
SUN2000-30K-MCO							
Test Conditions P/ P _{E_{max}}	Measurements						Limit
	Idc / In [%]						Idc/In
	L1	L2	L3				
30% - 40%	0.020	0.019	0.022				0.5%
60% - 70%	0.022	0.021	0.022				0.5%
> 95%	0.018	0.022	0.020				0.5%
Note(s):							

5.3.2	TABLE: Tests of three-phase inverter (Imbalance)						P
Test Conditions		Measurements					Limit
cosφ	S/S _{E_{max}} [%]	S _{asy} /S _{E_{max}} [%]					S _{asy} /S _{E_{max}} [%]
1.0	100	0.016	0.017	0.019	0.020	0.020	≤ ±5
1.0	50	0.022	0.025	0.027	0.026	0.023	
Max. un	100	0.027	0.028	0.027	0.028	0.028	
Max. un	50	0.026	0.026	0.025	0.025	0.025	
Max. ov	100	0.023	0.023	0.023	0.023	0.023	
Max. ov	50	0.022	0.023	0.023	0.024	0.023	
Note(s):							
S _{asy} : Max. Asymmetry power among three phases.							

5.4.2	TABLE: Measurement of active- and reactive power ranges (P&Q range)						P	
Test Conditions		Measurements				Δ Limit		
U/U _n	cosφ	U [V]	P _{max} [kW]	cosφ	S _{max} [kVA]	cosφ	P _{max} /P _{E_{max}}	S _{max} /S _{E_{max}}
0.9	1.0	207.49	49888.87	1.000	49888.87	--	≤102%	≤102%
1.0		230.43	49960.06	1.000	49960.08			
1.09		251.10	49945.23	1.000	49945.23			
0.9	Max.un	207.40	42819.69	0.900	47588.10	≤0.9(5)		
1.0		230.37	44930.71	0.900	49940.66			
1.09		251.04	44898.42	0.900	49913.50			
0.9	Max.ov	207.42	41658.29	0.900	46289.31			
1.0		230.41	44983.10	0.900	49977.75			
1.09		251.07	44943.10	0.900	49933.45			
Note(s):								

5.4.3(a)	TABLE: Active power reduction through setting provision (P control)		P
Test Conditions	Measurements		Limit
P/Pn [%]	P/P _{Emax} [%]	$\Delta P/P_{Emax}$ [%]	$\Delta P/Pn$ [%]
100	99.98	0.02	≤ 5%
90	89.98	0.02	
80	79.96	0.04	
70	69.95	0.05	
60	59.95	0.05	
50	49.99	0.01	
40	39.98	0.02	
30	29.95	0.05	
20	19.92	0.08	
10	9.90	0.1	
No disconnection occur			

5.4.3(b)	TABLE: Active power reduction through setting provision (P control)		P
Test Conditions	Measurements		Limit
P/Pn [%]	$\Delta P/\Delta t$ [%Pn/s]		$\Delta P/\Delta t$ [%Pn/s]
100->5	0.503		0.33-0.66
5->100	0.505		

5.4.3(d)	TABLE: Active power reduction through setting provision (P control)		P
Test Conditions	Measurements	Limit	
P/Pn [%]	T _{response} [s]	T _{response} [s]	
100->0	1.15	≤ 5	
Note(s):			

5.4.4(a)		TABLE: Active power output of PGU by over-frequency (LFISM-O)							P		
LFISM-O settings		f _{active}		f _{stop}			f _{deactive}		Droop		
		50.2		N/A			50.2		5%(40%P _M /Hz)		
Test Conditions		Measurements					Target	Tolerance	Limit		
f [Hz]	P _{prim} [%]	P/P _E max [%]	f [Hz]	T _{rise} [s]	T _{set} [s]	T _v [s]	P/P _E max [%]	ΔP/P _E max [%]	ΔP [%]	T _{rise} [s]	T _{set} [s]
50.00	100	100.96	50.00	--	--	--	100	0.96	≤±10	≤2	≤20
50.25	100	98.95	50.24	0.2	2.4	0.1	98	0.95			
50.70	100	80.77	50.70	0.4	2.7	0.2	80	0.77			
51.40	100	52.46	51.39	0.3	2.6	0.1	52	0.46			
50.70	100	80.75	50.69	0.4	2.3	0.2	80	0.75			
50.25	100	98.90	50.24	0.2	2.6	0.1	98	0.90			
50.00	100	100.91	49.99	0.1	2.0	0.1	100	0.91			
51.65	100	Disconnection					0	--			
50.15	100	No Reconnection					0	--			
Test Conditions		Measurements				Target	Tolerance	Limit			
f [Hz]	P _{prim} [%]	P/P _E max [%]	f [Hz]	ΔP/Δt [%/min]	P/P _E max [%]	ΔP/P _E max [%]	ΔP [%]	ΔP/Δt [%/min]			
50.00	100	100.87	50.00	8.12	100	0.87	≤±10	≤10			

Note(s):

Plotting diagram:

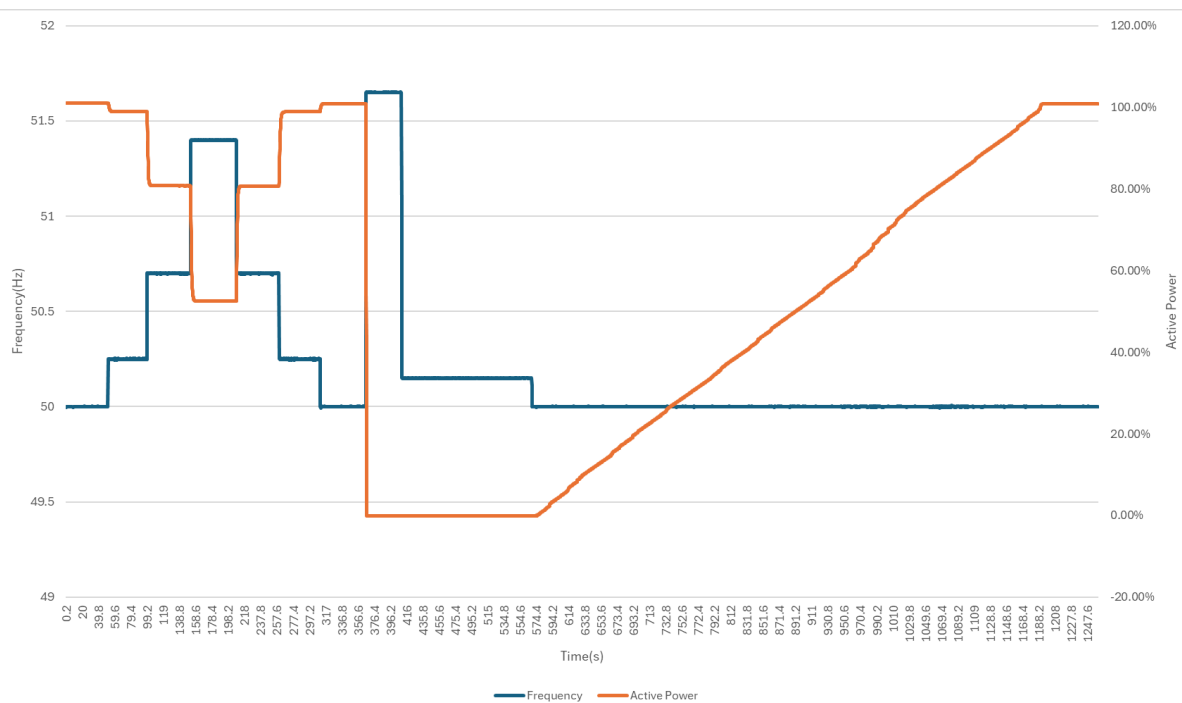

5.4.4(b) TABLE: Active power output of PGU by over-frequency (LFSM-O)									P		
LFSM-O settings		f _{active}		f _{stop}			f _{deactive}		Droop		
		50.5		N/A			50.2		12%(16.67%P _M /Hz)		
Test Conditions		Measurements					Target	Tolerance	Limit		
f [Hz]	P _{prim} [%]	P/P _E max [%]	f [Hz]	T _{rise} [s]	T _{set} [s]	T _v [s]	P/P _E max [%]	ΔP/P _E max [%]	ΔP [%]	T _{rise} [s]	T _{set} [s]
50.00	60	60.01	50.00	--	--	--	60	0.01	≤±10	≤2	≤20
50.40	60	59.99	50.40	--	--	--	60	-0.01			
50.70	60->100	57.05	50.70	0.8	2.4	0.1	58	-0.95			
51.40	100	50.15	51.40	0.7	2.1	0.2	51	-0.85			
50.70	100	57.01	50.70	0.5	2.6	0.2	58	-0.99			
50.40	100	59.99	50.40	0.6	2.5	0.1	60	-0.01			
Test Conditions		Measurements				Target	Tolerance	Limit			
f [Hz]	P _{prim} [%]	P/P _E max [%]	f [Hz]	ΔP/Δt [%/min]		P/P _E max [%]	ΔP/P _E max [%]	ΔP [%]	ΔP/Δt [%/min]		
50.00	100	101.01	50.00	8.97		100	1.01	≤±10	≤10		

Note(s):

Plotting diagram:

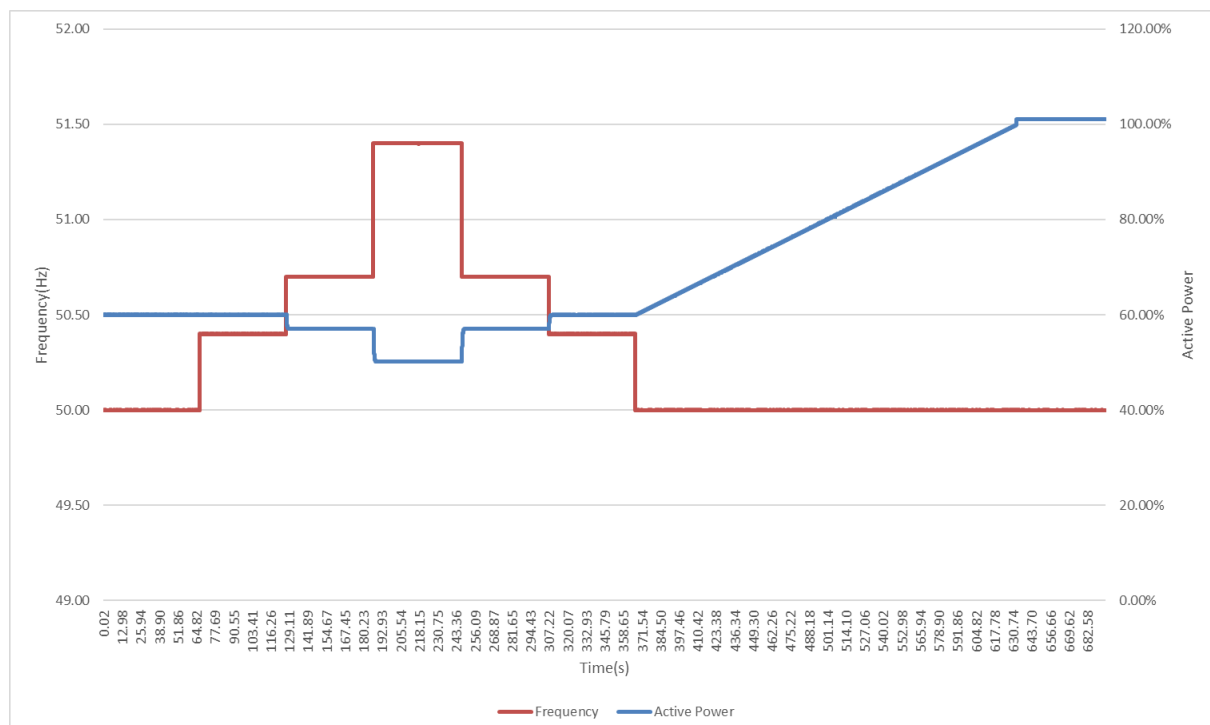

5.4.6(a)		TABLE: Active power output of PGU by under-frequency (LFSM-U)							P		
LFSM-U settings		f _{active}		f _{stop}			f _{deactive}		Droop		
		49.8		N/A			49.8		5%(40%P _E max/Hz)		
Test Conditions		Measurements					Target	Tolerance	Limit		
f [Hz]	P _{prim} [%]	P/P _E max [%]	f [Hz]	T _{rise} [s]	T _{set} [s]	T _v [s]	P/P _E max [%]	ΔP/P _E max [%]	ΔP [%]	T _{rise} [s]	T _{set} [s]
50.00	100	9.91	49.99	--	--	--	10	-0.09	≤±10	≤2	≤20
49.75	100	11.88	49.75	0.6	1.2	0.1	12	-0.12			
48.80	100	49.92	48.79	0.3	1.3	0.1	50	-0.08			
47.60	100	97.83	47.59	0.4	1.5	0.2	98	-0.17			
48.80	100	49.95	48.79	0.3	1.7	0.1	50	-0.05			
49.75	100	11.89	49.75	0.2	1.5	0.1	12	-0.11			
50.00	100	9.91	49.99	0.3	1.2	0.2	10	-0.09			
47.35	100	Disconnection					0	--			
47.40	100	No Reconnection					0	--			
Test Conditions		Measurements				Target	Tolerance	Limit			
f [Hz]	P _{prim} [%]	P/P _E max [%]	f [Hz]	ΔP/Δt [%/min]	P/P _E max [%]	ΔP/P _E max [%]	ΔP [%]	ΔP/Δt [%/min]			
50.00	100	9.99	50.00	8.95	10	-0.01	≤±10	≤10			

Note(s):

Product power was limited to 10% at the beginning of test by a lower priority command from user.

Plotting diagram:

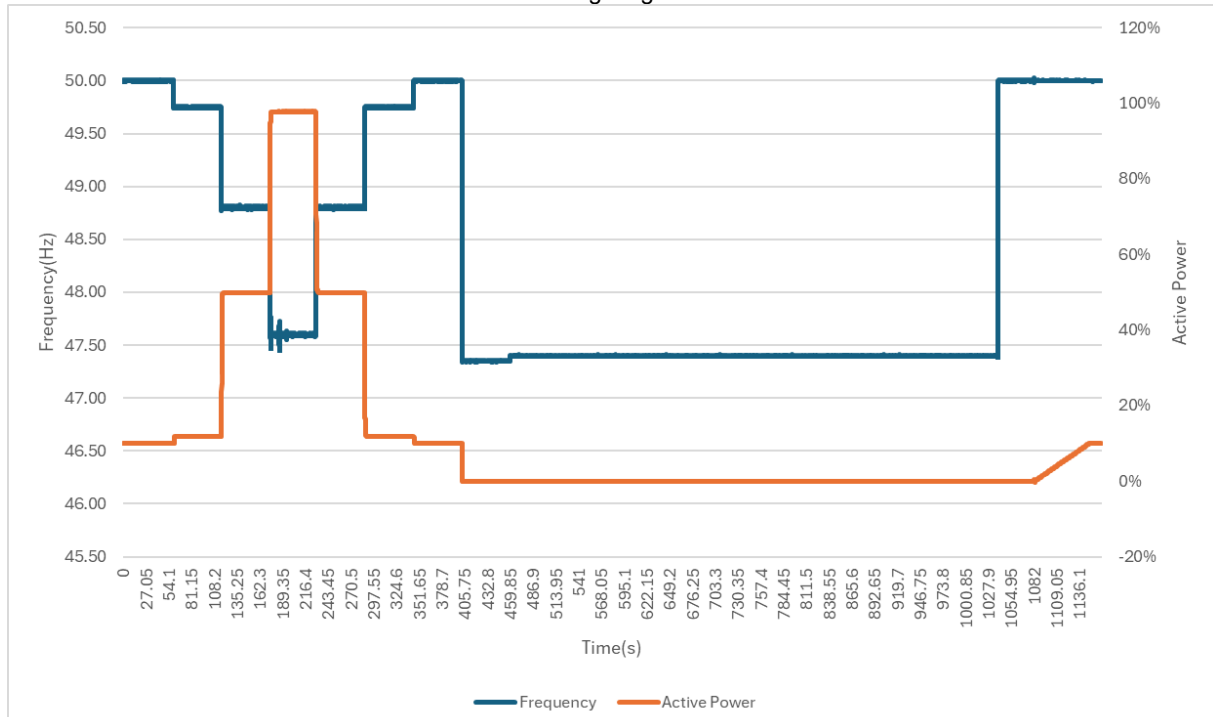

5.4.6(b)		TABLE: Active power output of PGU by under-frequency (LFSM-U)							P		
LFSM-U settings		f _{active}		f _{stop}			f _{deactive}		Droop		
		49.8		N/A			49.8		5%(40%P _E max/Hz)		
Test Conditions		Measurements					Target	Tolerance	Limit		
f [Hz]	P _{prim} [%]	P/P _E max [%]	f [Hz]	T _{rise} [s]	T _{set} [s]	T _v [s]	P/P _E max [%]	ΔP/P _E max [%]	ΔP [%]	T _{rise} [s]	T _{set} [s]
50.00	100	59.96	50.01	--	--	--	60	-0.04	±10	≤2	≤20
49.75	100	62.00	49.75	2.1	2.1	0.5	62	0.00			
49.20	100	84.02	49.19	2.0	2.0	0.2	84	0.02			
48.80	100	100.02	48.79	1.8	1.8	0.4	100	0.02			
49.20	100	84.02	49.10	1.9	1.9	0.2	84	0.02			
49.85	100	59.98	49.85	1.4	1.4	0.2	60	-0.02			
50.00	100	59.98	50.00	--	--	--	60	-0.02			

Note(s):

Product power was limited to 60% at the beginning of test by a lower priority command from user.

Plotting diagram:

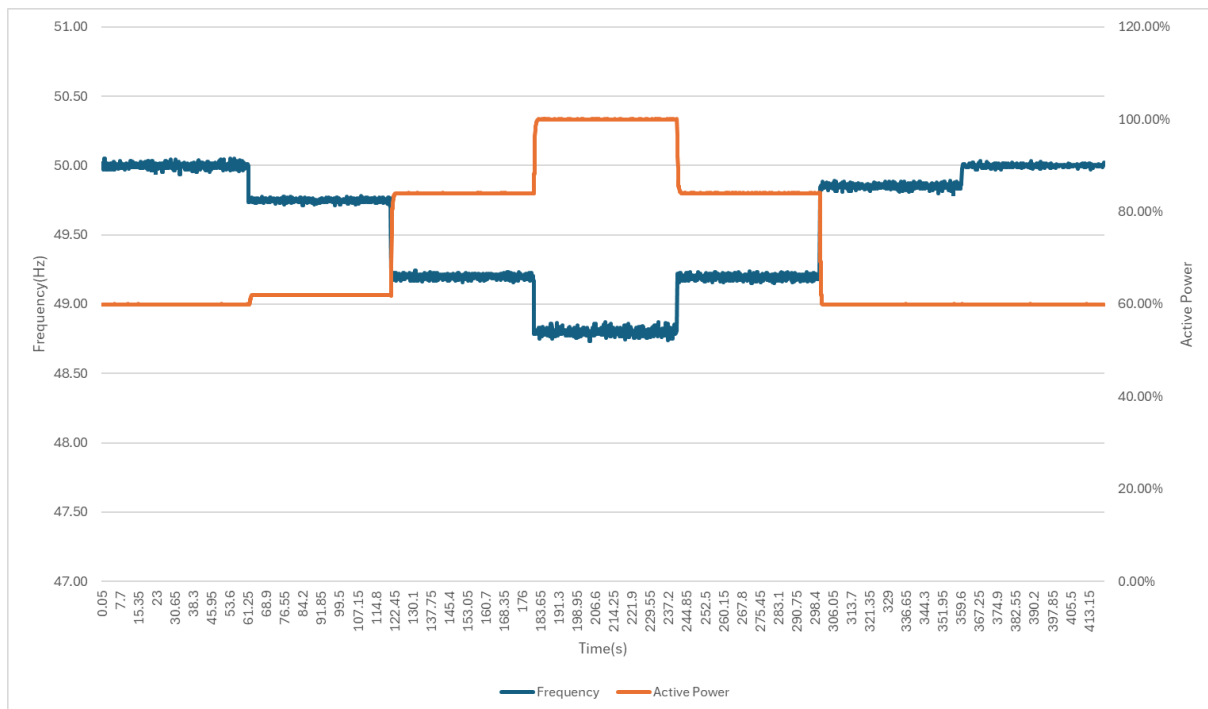

5.4.8.2		TABLE: Tests of reactive power / displacement factor setting accuracy (Fixed $\cos\phi$)							P	
Test Conditions			Measurements					Target	Tolerance	Limit
U/Un [%]	P/P _{E_{max}} [%]	$\cos\phi$	P [kW]	Q [kVar]	S [kVA]	U [V]	$\cos\phi$	Q [kVar]	$\Delta Q/P_{E_{max}}$ [%]	$\Delta Q/P_{E_{max}}$ [%]
90	50	0.90 under-excited	25.04	-11.98	27.76	207.52	0.901	-12.11	0.265	$\leq \pm 4$
90	S _{E_{max}}		45.11	-21.40	49.93	207.88	0.902	-21.79	0.786	$\leq \pm 4$
100	50		25.04	-11.98	27.76	230.50	0.901	-12.11	0.248	$\leq \pm 4$
100	S _{E_{max}}		49.61	-23.57	54.92	230.92	0.902	-24.22	1.294	$\leq \pm 4$
110	50		25.02	-11.98	27.74	253.51	0.901	-12.11	0.257	$\leq \pm 4$
110	S _{E_{max}}		49.61	-23.61	54.94	253.85	0.902	-24.22	1.220	$\leq \pm 4$
90	50	0.95 under-excited	24.98	-8.08	26.26	207.77	0.951	-8.22	0.265	$\leq \pm 4$
90	S _{E_{max}}		47.58	-15.23	49.96	208.24	0.951	-16.43	2.404	$\leq \pm 4$
100	50		25.02	-8.10	26.30	230.65	0.951	-8.22	0.241	$\leq \pm 4$
100	S _{E_{max}}		50.58	-16.22	53.12	231.20	0.951	-16.43	0.421	$\leq \pm 4$
110	50		25.03	-8.10	26.31	253.62	0.951	-8.22	0.239	$\leq \pm 4$
110	S _{E_{max}}		50.63	-16.28	53.18	254.12	0.951	-16.43	0.317	$\leq \pm 4$
90	50	0.90 over-excited	24.90	12.24	27.75	207.81	0.899	12.11	0.250	$\leq \pm 4$
90	S _{E_{max}}		44.72	22.11	49.89	208.26	0.898	21.79	0.634	$\leq \pm 4$
100	50		24.91	12.23	27.75	230.69	0.899	12.11	0.243	$\leq \pm 4$
100	S _{E_{max}}		49.25	24.34	54.93	231.26	0.898	24.22	0.235	$\leq \pm 4$
110	50		24.88	12.22	27.72	253.63	0.898	12.11	0.222	$\leq \pm 4$
110	S _{E_{max}}		49.25	24.30	54.92	254.17	0.898	24.22	0.153	$\leq \pm 4$
90	50	0.95 over-excited	24.93	8.34	26.29	207.73	0.949	8.22	0.235	$\leq \pm 4$
90	S _{E_{max}}		47.40	16.01	50.03	208.25	0.948	16.43	-0.842	$\leq \pm 4$
100	50		24.91	8.33	26.26	230.67	0.949	8.22	0.218	$\leq \pm 4$
100	S _{E_{max}}		50.36	16.97	53.14	231.23	0.949	16.43	1.076	$\leq \pm 4$
110	50		24.92	8.34	26.28	253.64	0.949	8.22	0.249	$\leq \pm 4$
110	S _{E_{max}}		50.38	16.94	53.15	254.16	0.949	16.43	1.016	$\leq \pm 4$

Note(s):

P-Q Diagram:

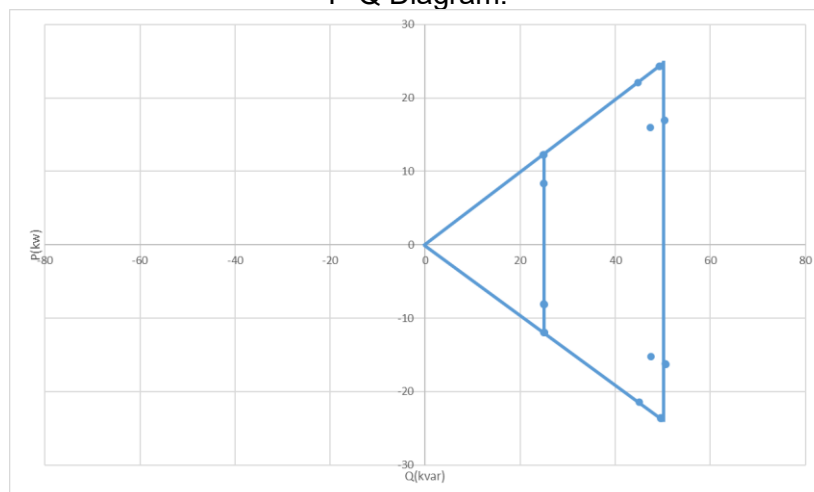

5.4.8.3(a)	TABLE: Tests of displacement factor- / active power character curve (cosφ(P))			P
cosφ (P) curve settings:	P/P _E max [%]	10	50	100
	cosφ	1.0	1.0	0.9un
	3Tau [s]	10		
Test Conditions				Limit
P _{dc} /P _{dc,r} [%]				ΔQ/P _E max [%]
100->10->100 with ramp ≤30%P _{dc,r} /min				≤±4.0

Plotting diagram:

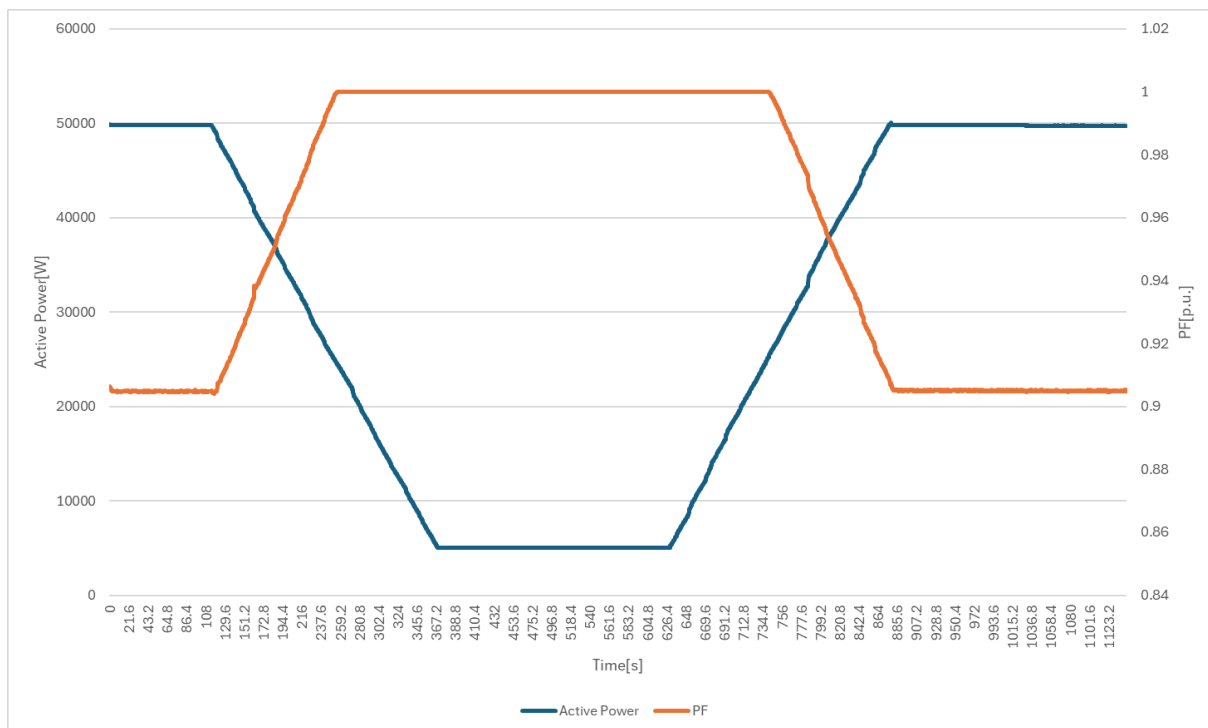

5.4.8.3(b)	TABLE: Tests of displacement factor- / active power character curve (cosφ(P))	P
Test Conditions	Measurements	Limit
$P_{rim}/P_{dc,r}$ [%]	Response time T [s]	Response time T [s]
100->40	9.7	Complied with PT-1 curve
40->100	9.8	
100->75	9.4	

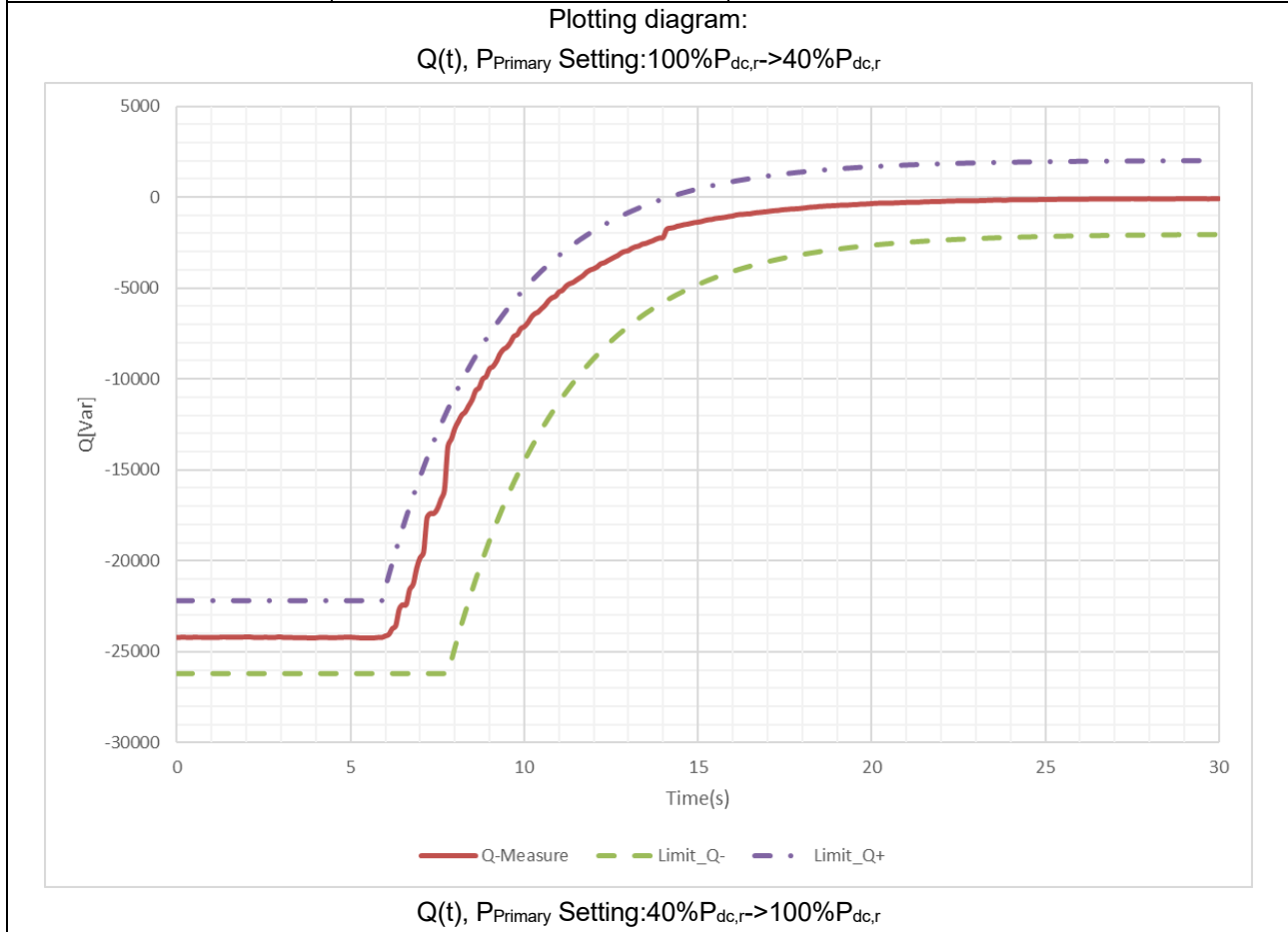

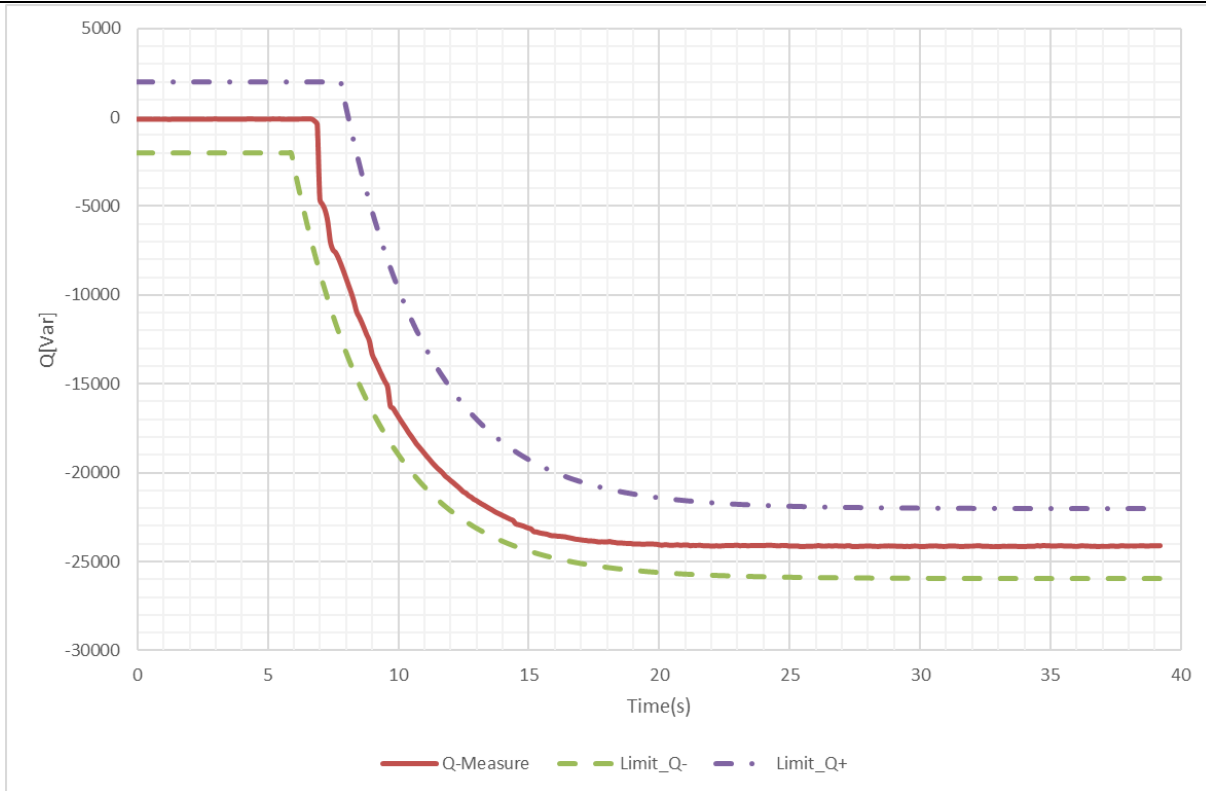

Q(t), P_{Primary} Setting: 100%P_{dc,r} > 75%P_{dc,r}

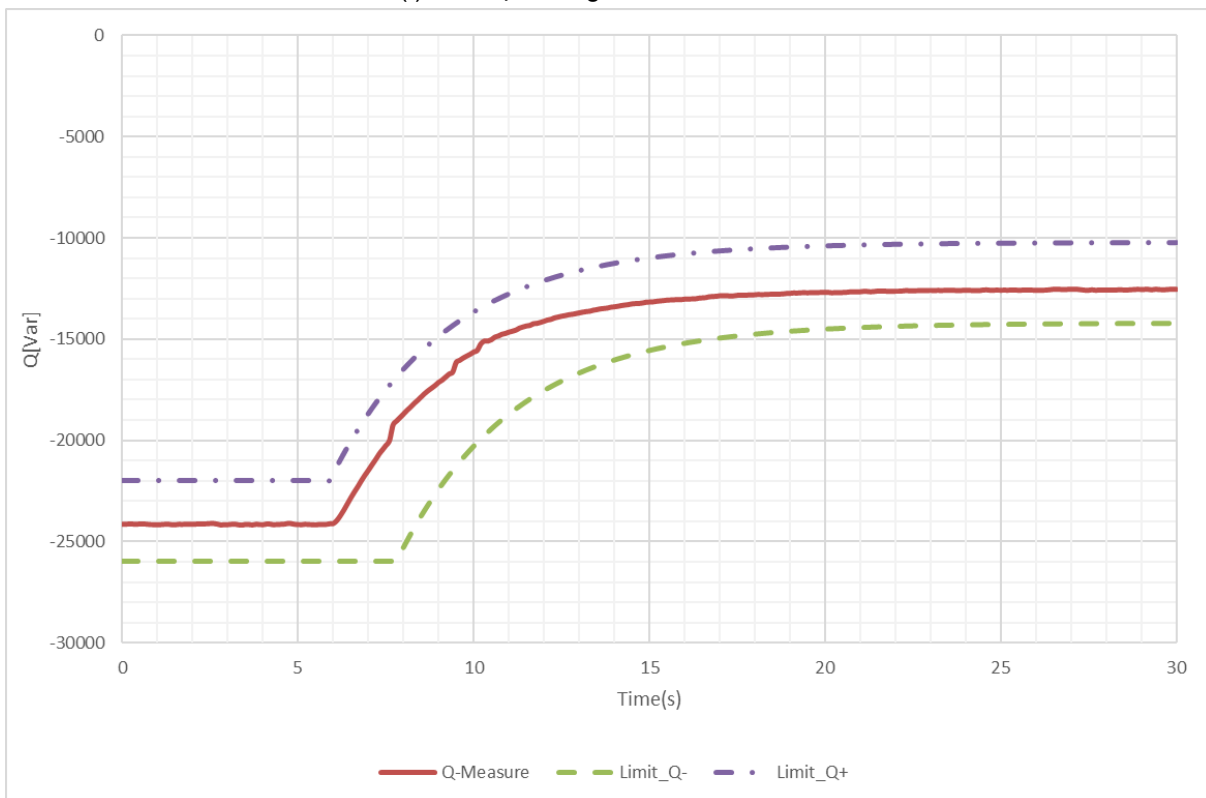

5.4.8.4(a)	TABLE: Tests of reactive power-voltage character curve (Q(U))					P
Q (U) curve settings:	U/Un	0.93	0.97	1.03	1.07	
	Q/SEmax	+0.436	0	0	-0.436	
	3Tau [s]	6				
Test Conditions		Measurements		Target	Tolerance	Limit
U/Un[%]		Q[kVar]	U [V]	Q[kVar]	$\Delta Q/P_{E_{max}}[\%]$	ΔQ [kVar]
100	0.35	230.27	0	0.636%		
99	0.36	227.98	0	0.655%		
98	0.36	225.59	0	0.655%		
97	0.36	223.30	0	0.655%		
96	6.36	221.03	6.00	0.655%		
95	12.37	218.75	11.99	0.691%		
94	18.36	216.44	17.99	0.673%		
93	24.34	213.98	23.98	0.655%		
92	24.33	211.79	23.98	0.636%		
91	24.33	209.39	23.98	0.636%		
90	24.33	207.19	23.98	0.636%		
91	24.32	209.39	23.98	0.618%		
92	24.33	211.79	23.98	0.636%		
93	24.33	214.00	23.98	0.636%		
94	18.36	216.45	17.99	0.673%		
95	12.38	218.77	11.99	0.709%		
96	6.37	221.06	6.00	0.673%		
97	0.36	223.34	0	0.655%		
98	0.36	225.63	0	0.655%		
99	0.36	228.02	0	0.655%		
100	0.35	230.31	0	0.636%		
101	0.34	232.50	0	0.618%		
102	0.34	234.59	0	0.618%		
103	0.33	236.98	0	0.600%		
104	-5.66	239.37	-6.00	0.618%		
105	-11.65	241.54	-11.99	0.618%		
106	-17.63	243.92	-17.99	0.655%		
107	-23.62	246.28	-23.98	0.655%		
108	-23.63	248.48	-23.98	0.636%		
109	-23.63	250.87	-23.98	0.636%		
110	-23.63	252.02	-23.98	0.636%		
109	-23.63	250.86	-23.98	0.636%		
108	-23.63	248.48	-23.98	0.636%		
107	-23.62	246.29	-23.98	0.655%		
106	-17.63	243.93	-17.99	0.655%		
105	-11.65	241.55	-11.99	0.618%		
104	-5.67	239.37	-6.00	0.600%		
103	0.33	236.99	0	0.600%		
102	0.33	234.59	0	0.600%		
101	0.33	232.50	0	0.600%		
100	0.34	230.31	0	0.618%		

$$\pm(0.01 \cdot U_{n,Y} \cdot K_{QU} + 0.04 P_{E_{max}}),$$

$$K_{QU} = |Q_{max}| / (0.04 \cdot U_{n,Y})$$

Diagram:

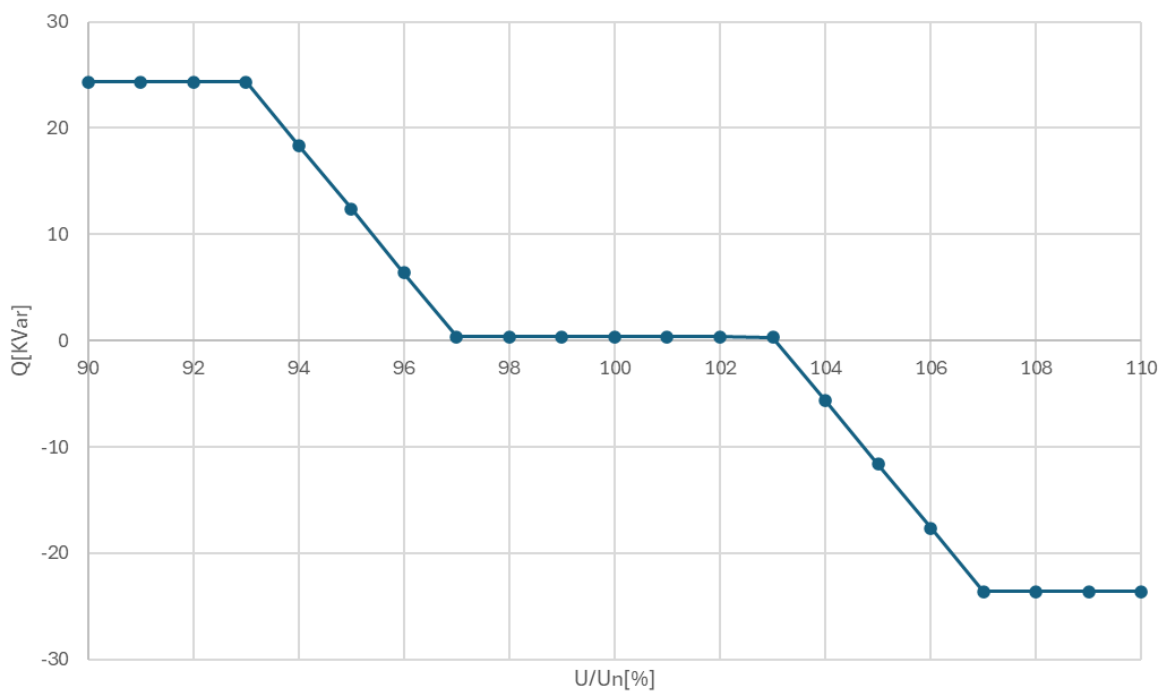

5.4.8.4(b)	TABLE: Tests of reactive power-voltage character curve (Q(U))					P
Test Conditions	Measurement			Target	Limit	
	Settling time T [s]	Q _{Start} [kVar]	Q _{end} [kVar]	Q _{end} /S _{E_{max}} [%]	Settling time T [s]	ΔQ _{end} /P _{E_{max}} [%]
Un -> Un+ΔU _{ind,Y}	9.2	0.36	-20.06	-0.85Q _{max}	PT1 complied, See attached curve for detail.	--
Un+ΔU _{ind,Y} -> Un	9.4	-20.06	0.36	0		≤±4
Un -> Un+ΔU _{ind,Y}	10.4	0.36	-20.06	-0.85Q _{max}		--
Un+ΔU _{ind,Y} -> Un	9.6	-20.06	0.36	0		≤±4
Un -> Un+ΔU _{ind,Y}	9.5	0.35	-20.06	-0.85Q _{max}		--
Un+ΔU _{ind,Y} -> Un	9.1	-20.05	0.37	0		≤±4
Un -> Un+ΔU _{cap,Y}	9.8	0.36	20.76	0.85Q _{max}		--
Un+ΔU _{cap,Y} -> Un	9.7	20.74	0.36	0		≤±4
Un -> Un+ΔU _{cap,Y}	9.7	0.36	20.75	0.85Q _{max}		--
Un+ΔU _{cap,Y} -> Un	9.5	20.76	0.37	0		≤±4
Un -> Un+ΔU _{cap,Y}	9.6	0.36	20.75	0.85Q _{max}		--
Un+ΔU _{cap,Y} -> Un	9.8	20.75	0.35	0		≤±4

Plotting Diagram

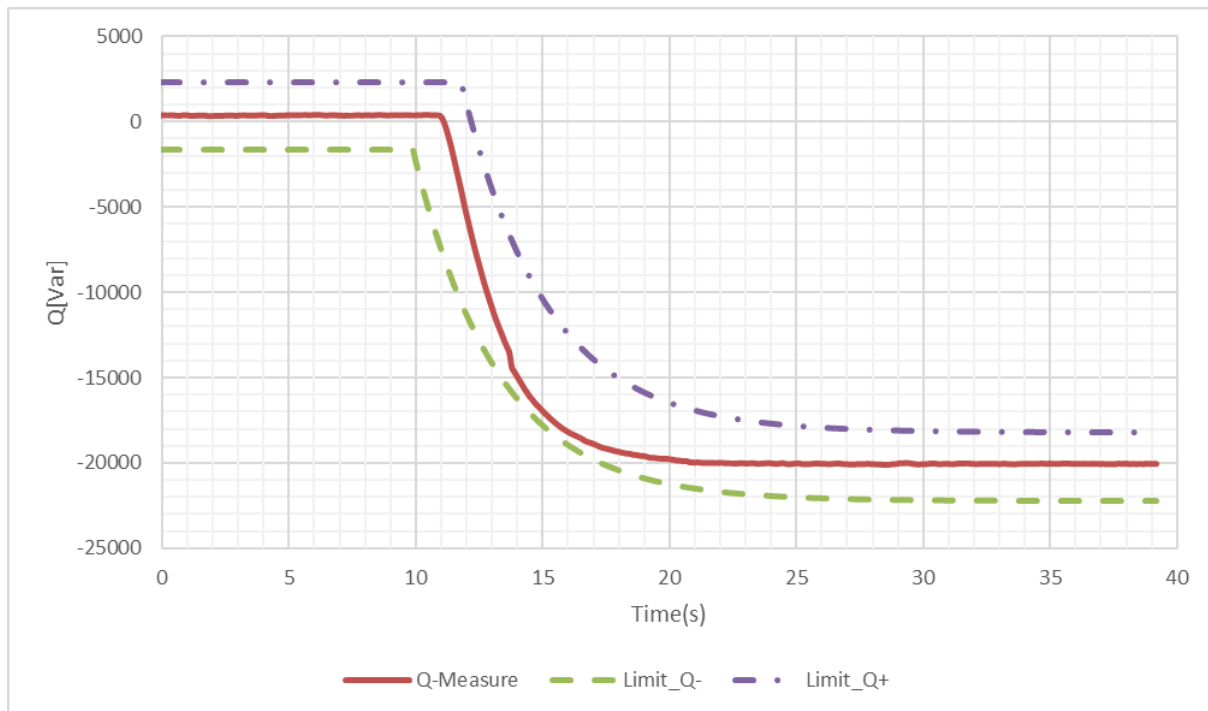

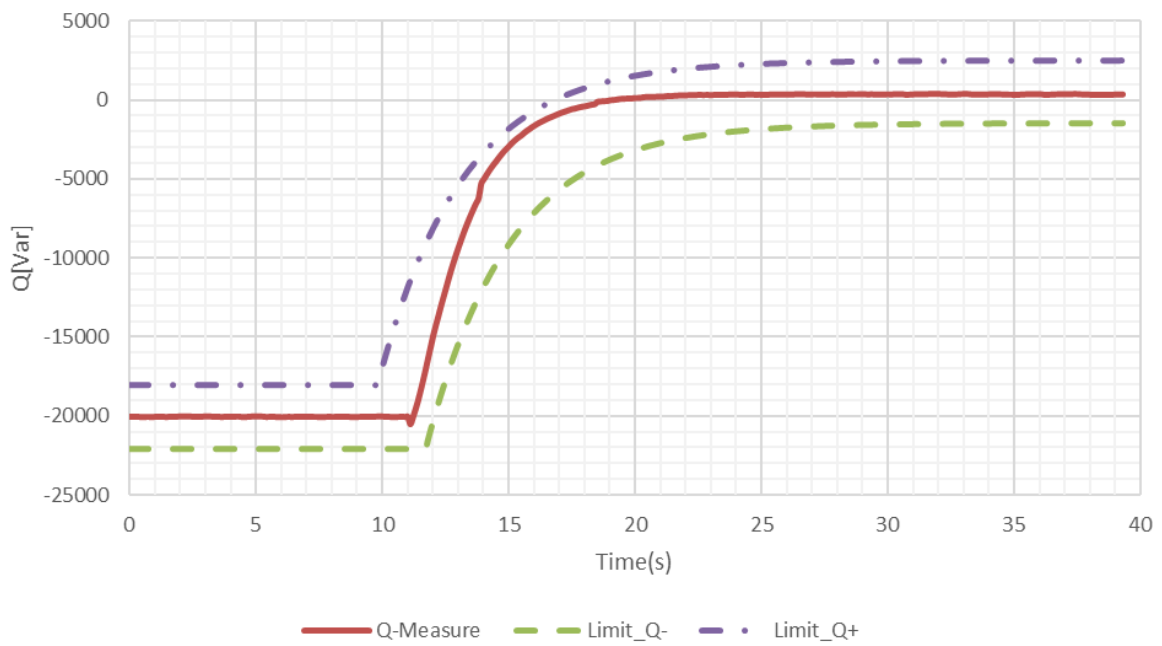
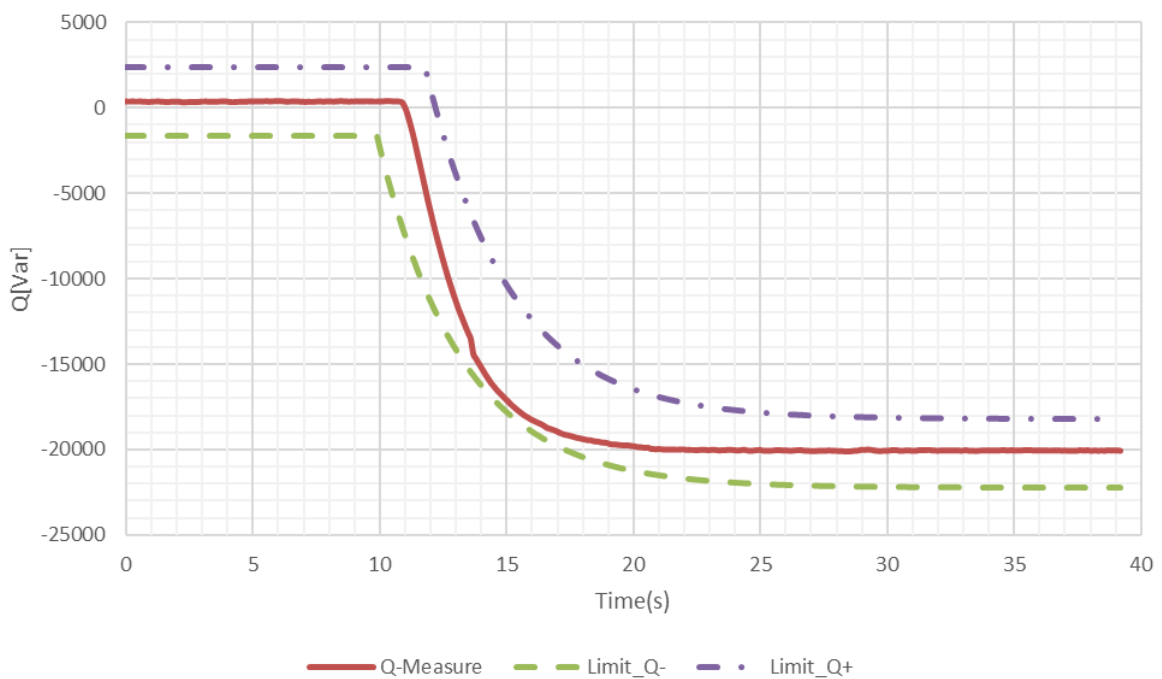
 Un -> Un+ΔU_{ind,Y}

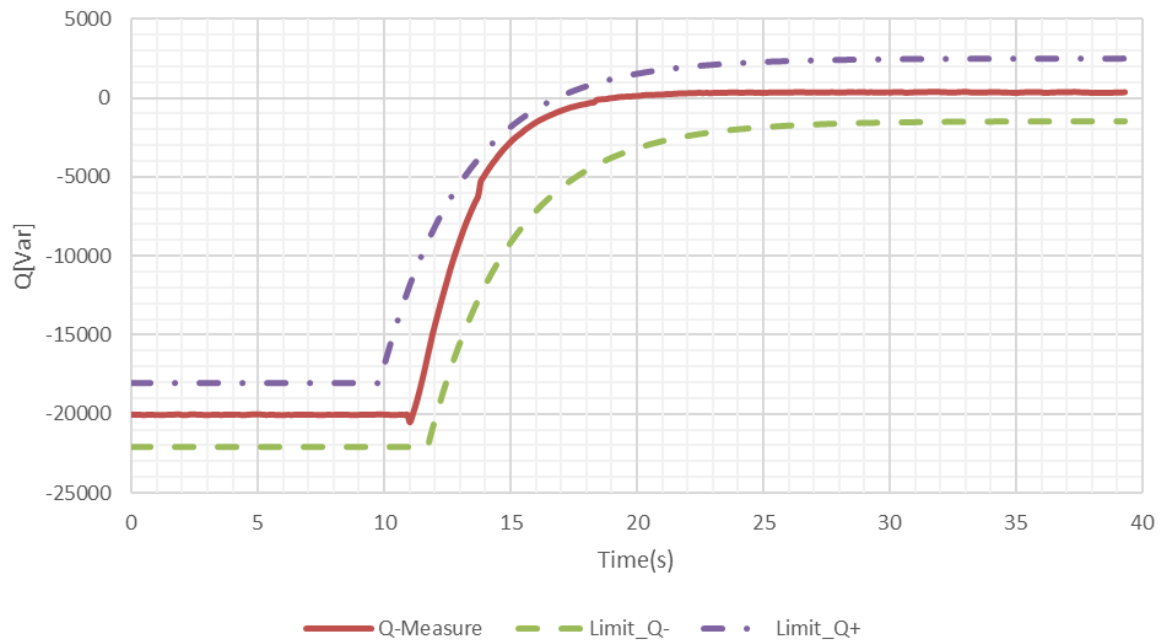
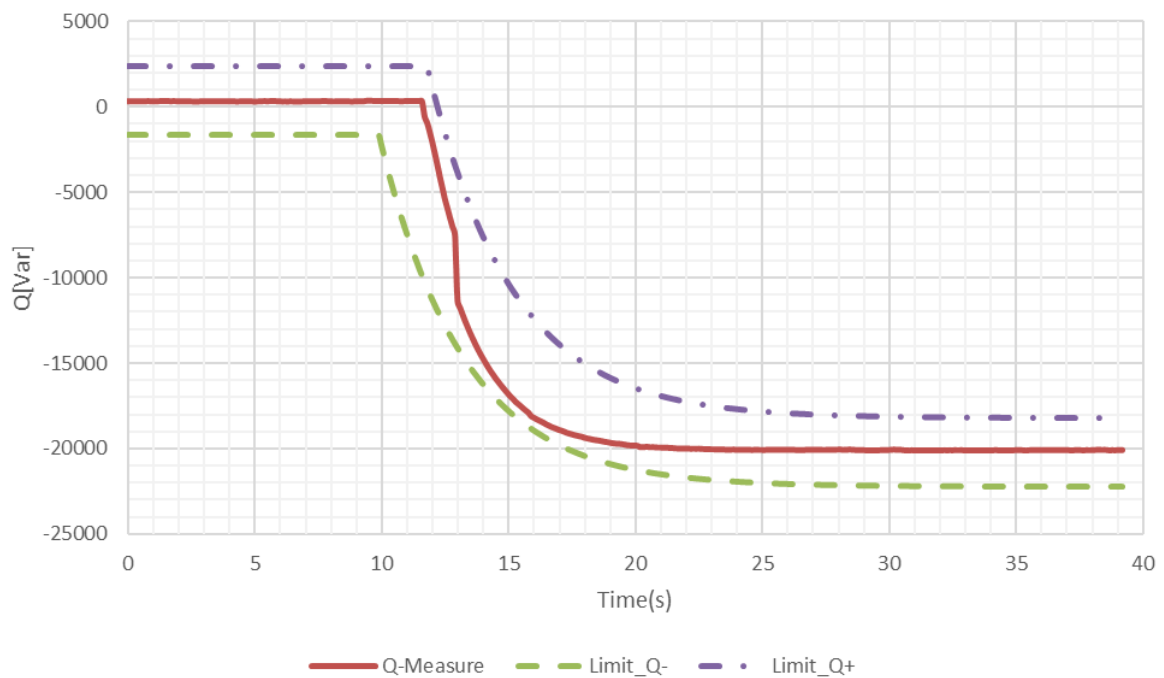

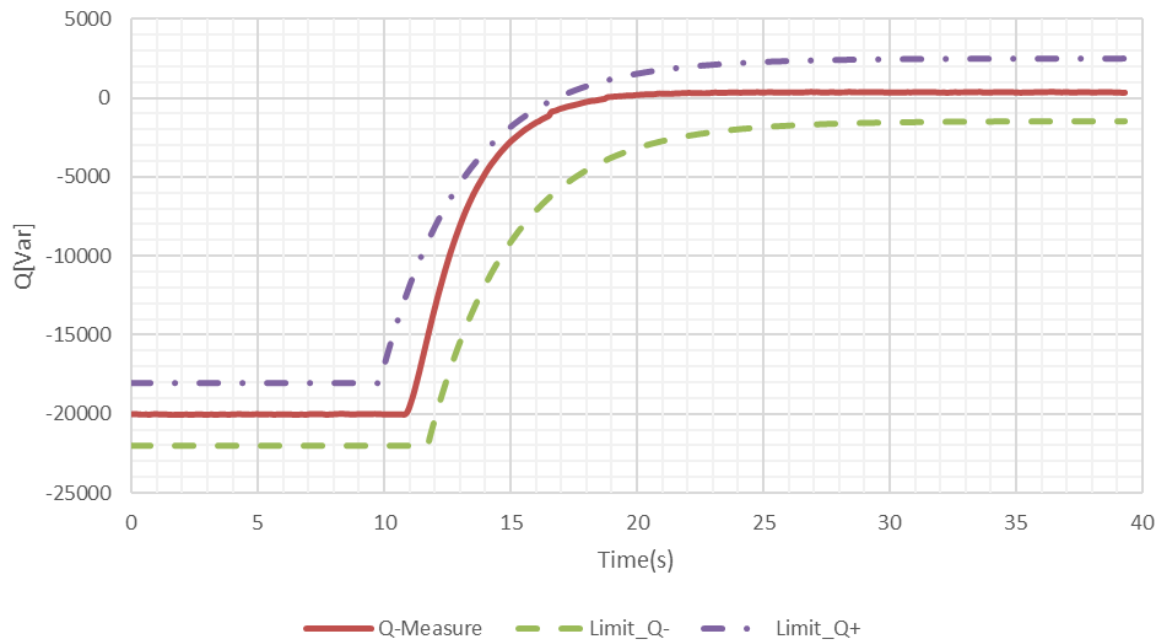
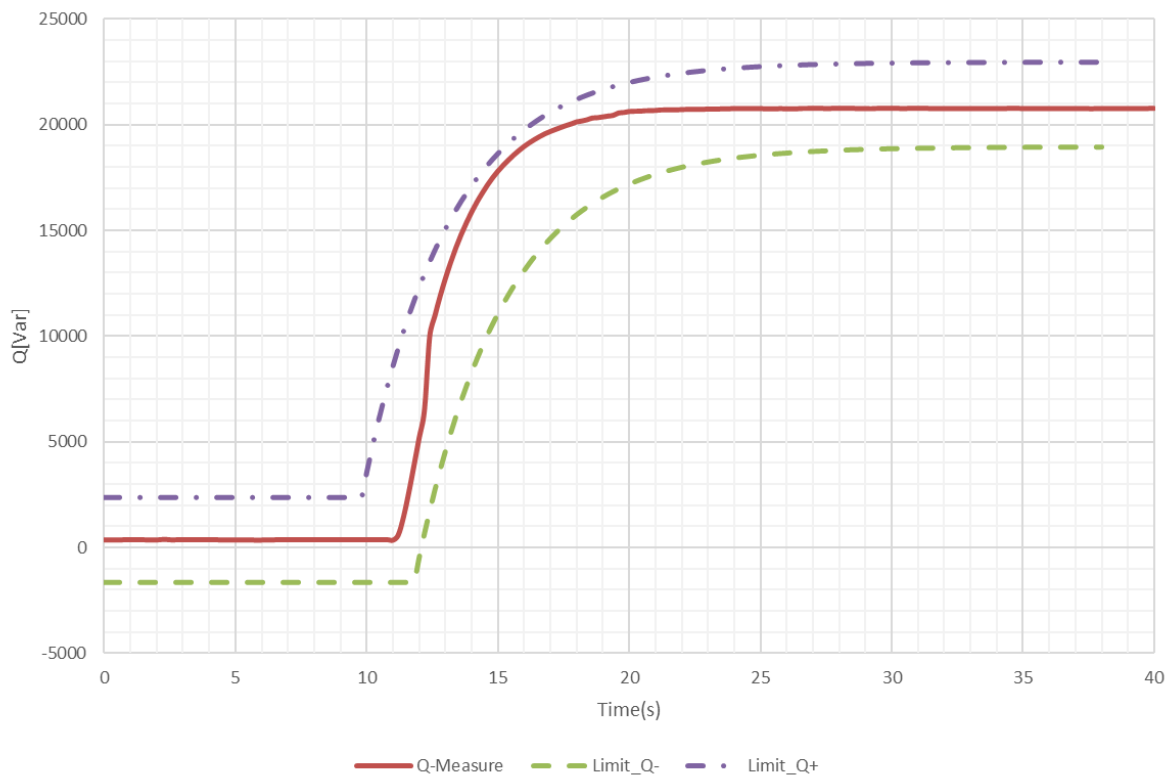
 $U_n + \Delta U_{ind,Y} \rightarrow U_n$

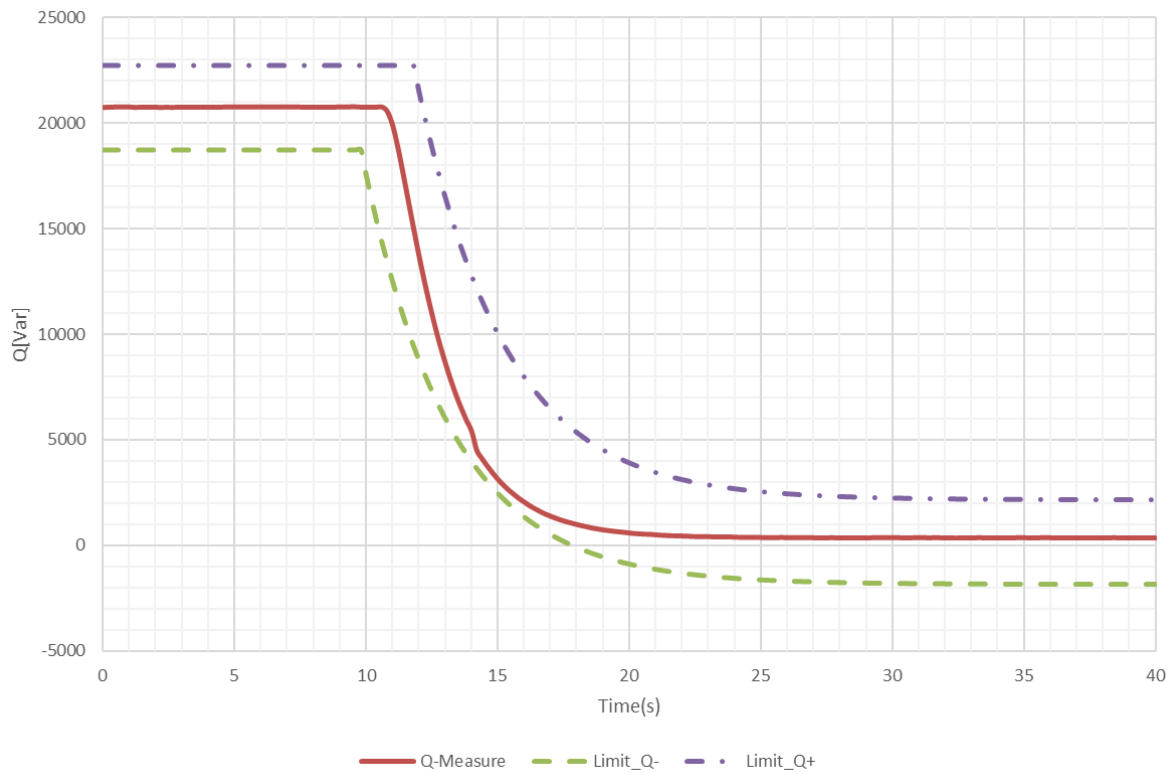
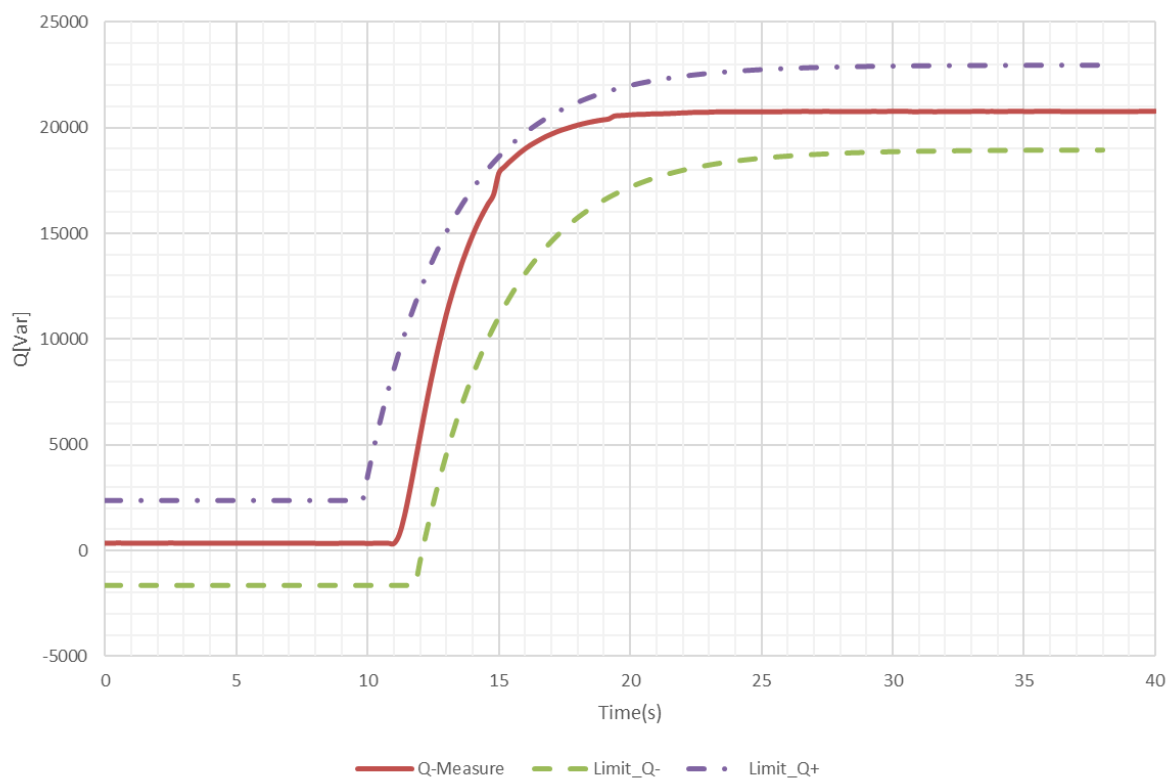
 $U_n \rightarrow U_n + \Delta U_{ind,Y}$

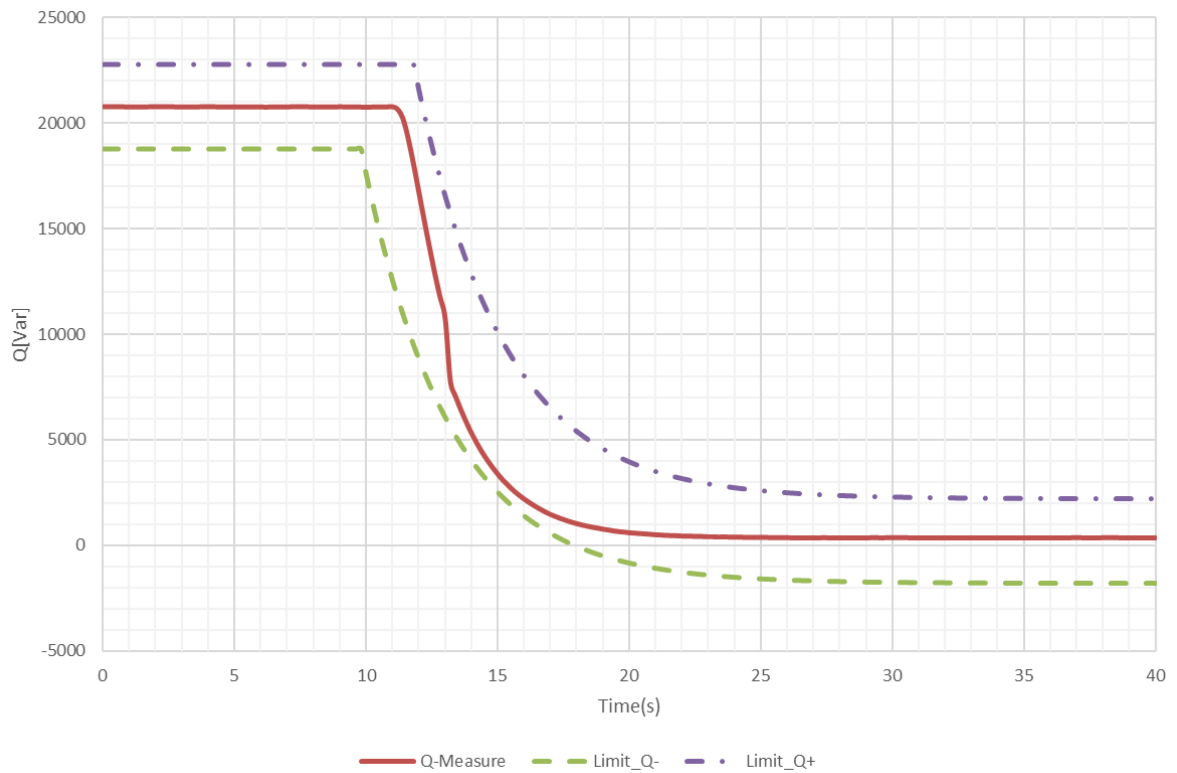
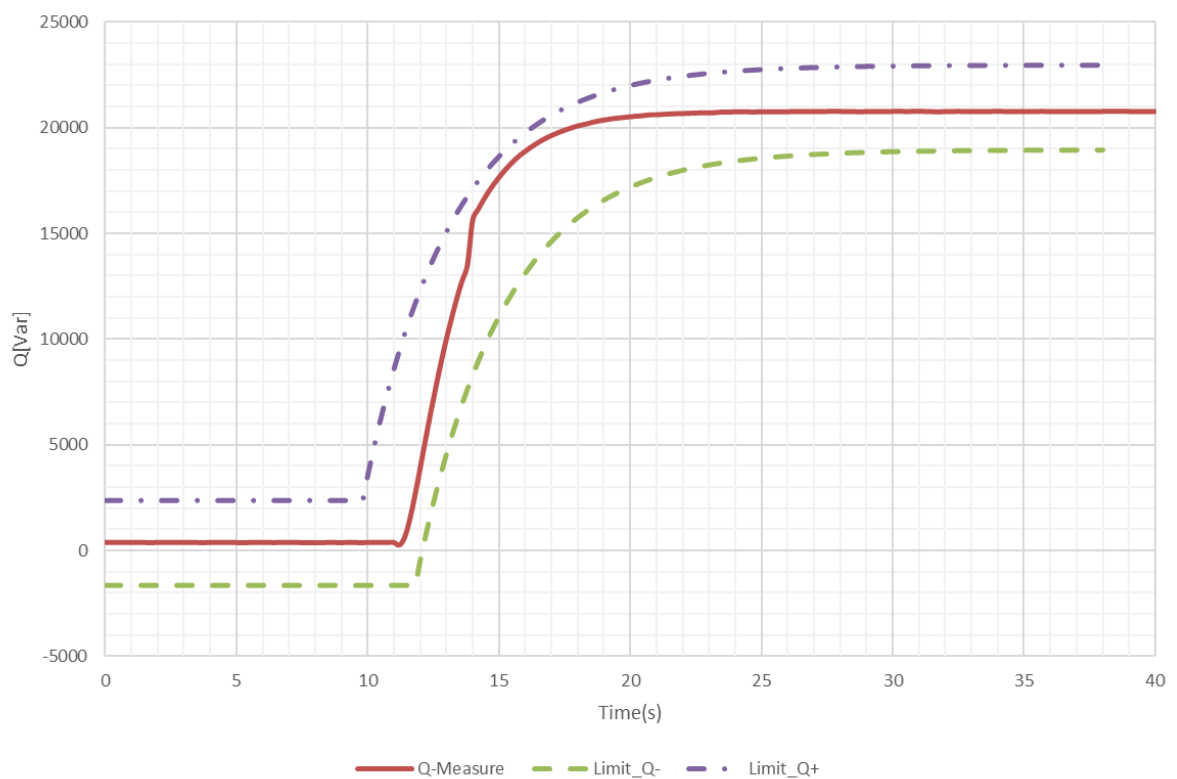
 $U_n + \Delta U_{ind,Y} \rightarrow U_n$

 $U_n \rightarrow U_n + \Delta U_{ind,Y}$

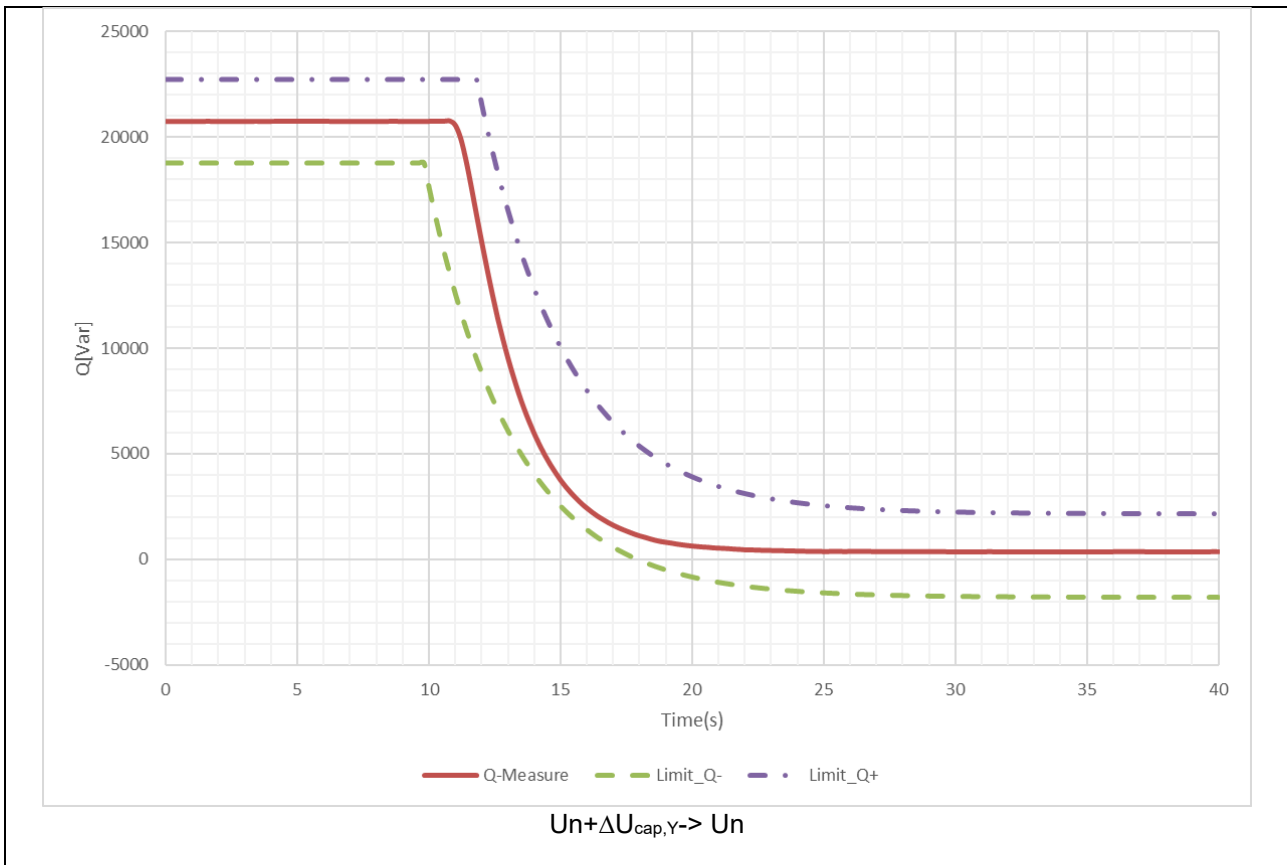
 $U_n + \Delta U_{ind,\gamma} \rightarrow U_n$

 $U_n \rightarrow U_n + \Delta U_{cap,\gamma}$

 $U_n + \Delta U_{cap,Y} \rightarrow U_n$

 $U_n \rightarrow U_n + \Delta U_{cap,Y}$

 $U_n + \Delta U_{cap,Y} \rightarrow U_n$

 $U_n \rightarrow U_n + \Delta U_{cap,Y}$



Prüfbericht-Nr.: CN25NMLN 001 Attachment 1
 Test report no.:

Seite 33 von 172
 Page 33 of 172

5.5.2, 5.5.4, 5.5.6		TABLE: NS-protection, Integrated interface switch (Functional safety)					P
The max. initial short-circuited current I_k'' [A]:				84			
Switch type:				HF167F- 200/12-H3F			
Manufacturer:				Xiamen Hongfa Electroacoustic Co., Ltd			
DIN EN 62109-1 cert/report No.:				WT258501700			
No.	component No.	fault	test voltage (V)	test time	fuse No.	fuse current (A)	result
1.	Cooling system	Blanketing	DC530V	7h	--	--	The inverter operated normally, protection remains in effect, no hazard.
2.	Cooling fan 1	Stopped	DC530V	7h	--	--	The inverter operated normally, protection remains in effect, no hazard.
3.	Cooling fan 2	Stopped	DC530V	7h	--	--	The inverter operated normally, protection remains in effect, no hazard.
4.	Cooling fan 3	Stopped	DC530V	7h	--	--	The inverter operated normally, protection remains in effect, no hazard.
5.	PCE output	Short circuit	DC530V	10 Min	--	--	Inverter stopped operation immediately after short-circuit. No output power feed into grid. No components damage, no hazard.
6.	PCE output	Phase sequence or polarity incorrect	DC530V	10 Min	--	--	Inverter operated normally. no hazard.
7.	PCE output	U-Phase mis-wiring grid connection	DC530V	10 Min	--	--	Inverter shut down for immediately due to islanding detection. No back-feed voltage observed onto mains side. No output power feed into grid. no hazard.
8.	PCE output	V-Phase mis-wiring grid connection	DC530V	10 Min	--	--	Inverter shut down for immediately due to islanding detection. No back-feed voltage observed onto mains side. No output power feed into grid. no hazard.

9.	PCE output	W-Phase mis-wiring grid connection	DC530V	10 Min	--	--	Inverter shut down for immediately due to islanding detection. No back-feed voltage observed onto mains side. No output power feed into grid. no hazard.
10.	PCE input	Reversed	DC530V	10 Min	--	--	Inverter cannot start up. no hazard.
11.	Transformer T701 Pin (1,3)	Short circuit	DC530V	10 Min	--	--	Inverter stop operation immediately after short-circuit. No output power feed into grid. no hazard.
12.	C402	Short circuit	DC530V	10 Min	--	--	Inverter stop operation immediately after short-circuit. No output power feed into grid. no hazard.
supplementary information							

5.5.7(a)	TABLE: Protection devices and protection settings (OV/UV)					P
Condition	Setting U/Un [%]	Measurement				Limitation $\Delta U/Un$ [%]
		Trip value [V]				
		L123	L1	L2	L3	
U>>	125	286.98	287.40	287.50	286.83	≤±1.0
U<	80	184.42	183.37	183.37	182.79	
U<<	45	103.91	103.46	103.35	103.31	
Condition	Setting U/Un [%]	Measurement				Limitation $\Delta U/Un$ [%]
		Trip value [V]				
		L123	L1-L2	L2-L3	L3-L1	
U>>	125	--	498.02	497.16	496.82	≤±1.0
U<	80	--	317.71	317.44	319.26	
U<<	45	--	181.87	183.45	183.48	
Condition	Setting [ms]	Measurement				Limitation [ms]
		Trip time [ms]				
		L123	L1	L2	L3	
U>>	100	125	120	145	140	≤200
U<	3000	3028	3018	3023	3033	3000-3100
U<<	300	315	340	350	330	300-400
Condition	Setting	Measurement				Limitation [ms]
		Trip time [ms]				
		L123	L1-L2	L2-L3	L3-L1	
U>>	100	--	140	141	155	≤200
U<	3000	--	3023	3023	3038	3000-3100
U<<	300	--	360	345	340	300-400
Condition	Setting [s]	Measurement				Limitation [s]
		Trip time [s]				
		L123	L1	L2	L3	
U> 230->257.6	500	478	475	470	481	450-550
U> 230->248.4	No disconnect	No disconnect				No disconnect
U> 244->262.2	300	275	272	273	283	225-375
Note(s): Tests on L-L voltages are applicable to product over 30kVA.						

5.5.7(b)	TABLE: Protection devices and protection settings (OF/UF)		P
Condition	Setting f [Hz]	Measurement	Limitation $\Delta f/f_n$ [%]
		Trip value [Hz]	
f>	51.5	51.50	$\leq \pm 0.1$
f<	47.5	47.50	
Condition	Setting [ms]	Measurement	Limitation [ms]
		Trip time [ms]	
f>	100	127	≤ 200
f<	100	133	≤ 200
Note(s):			

5.5.7(c)	TABLE: Protection devices and protection settings		P
1.	The last 5 fault indication can be read		Pass
	Fault 1: Grid Failure		
	Fault 2: Abnormal grounding		
	Fault 3: Grid overfrequency		
	Fault 4: Grid underfrequency		
	Fault 5: Grid Overvoltage		
2.	Fault indication can be read after a supply interruption $\leq 3s$		Pass
	Fault 1: Grid Failure		
	Fault 2: Abnormal grounding		
	Fault 3: Grid overfrequency		
	Fault 4: Grid underfrequency		
	Fault 5: Grid Overvoltage		

5.5.9	TABLE: Constructional features of NS protection		P
1.	The protection settings can be read on PGU or data interface equipment	Pass	
		Connecting to the Device on the App	
2.	The NS protection settings shall be protected.	Pass	
		Protection type: Password Protected	
3.	If all protection settings are fixed	Pass	
		Protection settings: Can be set but requires password authentication	

5.5.10	TABLE: Islanding detection (per IEC 62116: 2014)					P
Power 100%						
Conditions	P _R [kW]	Q _L [kVar]	Q _C [kVar]	Q _r	Trip time [ms]	Limitation [ms]
P _R : -10% Q _C : +10%	L1: 14.987	L1: 18.341	L1: 16.700	1.168	176	9000
	L2: 14.995	L2: 18.322	L2: 16.696	1.166		
	L3: 14.999	L3: 18.327	L3: 16.704	1.167		
P _R : -10% Q _C : +5%	L1: 14.987	L1: 17.508	L1: 16.700	1.141	194	9000
	L2: 14.995	L2: 17.489	L2: 16.696	1.140		
	L3: 14.999	L3: 17.494	L3: 16.704	1.140		
P _R : -10% Q _C : 0%	L1: 14.987	L1: 16.674	L1: 16.700	1.113	297	9000
	L2: 14.995	L2: 16.657	L2: 16.696	1.112		
	L3: 14.999	L3: 16.661	L3: 16.704	1.112		
P _R : -10% Q _C : -5%	L1: 14.987	L1: 15.840	L1: 16.700	1.085	194	9000
	L2: 14.995	L2: 15.824	L2: 16.696	1.084		
	L3: 14.999	L3: 15.828	L3: 16.704	1.084		
P _R : -10% Q _C : -10%	L1: 14.987	L1: 15.007	L1: 16.700	1.056	178	9000
	L2: 14.995	L2: 14.991	L2: 16.696	1.055		
	L3: 14.999	L3: 14.995	L3: 16.704	1.055		
P _R : -5% Q _C : +10%	L1: 15.820	L1: 18.341	L1: 16.700	1.106	176	9000
	L2: 15.828	L2: 18.322	L2: 16.696	1.105		
	L3: 15.832	L3: 18.327	L3: 16.704	1.105		
P _R : -5% Q _C : -10%	L1: 15.820	L1: 15.007	L1: 16.700	1.001	191	9000
	L2: 15.828	L2: 14.991	L2: 16.696	1.000		
	L3: 15.832	L3: 14.995	L3: 16.704	1.000		
P _R : 0% Q _C : +10%	L1: 16.652	L1: 18.341	L1: 16.700	1.051	173	9000
	L2: 16.661	L2: 18.322	L2: 16.696	1.050		
	L3: 16.665	L3: 18.327	L3: 16.704	1.050		
P _R : -5% Q _C : +5%	L1: 15.820	L1: 17.508	L1: 16.700	1.081	200	9000
	L2: 15.828	L2: 17.489	L2: 16.696	1.080		
	L3: 15.832	L3: 17.494	L3: 16.704	1.080		
P _R : -5% Q _C : 0%	L1: 15.820	L1: 16.674	L1: 16.700	1.055	256	9000
	L2: 15.828	L2: 16.657	L2: 16.696	1.054		
	L3: 15.832	L3: 16.661	L3: 16.704	1.054		
P _R : -5% Q _C : -5%	L1: 15.820	L1: 15.840	L1: 16.700	1.028	197	9000
	L2: 15.828	L2: 15.824	L2: 16.696	1.027		
	L3: 15.832	L3: 15.828	L3: 16.704	1.027		
P _R : 0% Q _C : +5%	L1: 16.652	L1: 17.508	L1: 16.700	1.027	200	9000
	L2: 16.661	L2: 17.489	L2: 16.696	1.026		
	L3: 16.665	L3: 17.494	L3: 16.704	1.026		

PR: 0% QC: 0%	L1: 16.652	L1: 16.674	L1: 16.700	1.002	275	9000
	L2: 16.661	L2: 16.657	L2: 16.696	1.001		
	L3: 16.665	L3: 16.661	L3: 16.704	1.001		
PR: 0% QC: -5%	L1: 16.652	L1: 15.840	L1: 16.700	0.977	183	9000
	L2: 16.661	L2: 15.824	L2: 16.696	0.976		
	L3: 16.665	L3: 15.828	L3: 16.704	0.976		
PR: +5% QC: +5%	L1: 17.485	L1: 17.508	L1: 16.700	0.978	207	9000
	L2: 17.494	L2: 17.489	L2: 16.696	0.977		
	L3: 17.498	L3: 17.494	L3: 16.704	0.977		
PR: +5% QC: 0%	L1: 17.485	L1: 16.674	L1: 16.700	0.954	231	9000
	L2: 17.494	L2: 16.657	L2: 16.696	0.953		
	L3: 17.498	L3: 16.661	L3: 16.704	0.953		
PR: +5% QC: -5%	L1: 17.485	L1: 15.840	L1: 16.700	0.930	194	9000
	L2: 17.494	L2: 15.824	L2: 16.696	0.929		
	L3: 17.498	L3: 15.828	L3: 16.704	0.929		
PR: 0% QC: -10%	L1: 16.652	L1: 15.007	L1: 16.700	0.951	182	9000
	L2: 16.661	L2: 14.991	L2: 16.696	0.950		
	L3: 16.665	L3: 14.995	L3: 16.704	0.950		
PR: +5% QC: +10%	L1: 17.485	L1: 18.341	L1: 16.700	1.001	178	9000
	L2: 17.494	L2: 18.322	L2: 16.696	1.000		
	L3: 17.498	L3: 18.327	L3: 16.704	1.000		
PR: +5% QC: -10%	L1: 17.485	L1: 15.007	L1: 16.700	0.905	187	9000
	L2: 17.494	L2: 14.991	L2: 16.696	0.904		
	L3: 17.498	L3: 14.995	L3: 16.704	0.904		
PR: +10% QC: +10%	L1: 18.317	L1: 18.341	L1: 16.700	0.955	181	9000
	L2: 18.327	L2: 18.322	L2: 16.696	0.954		
	L3: 18.332	L3: 18.327	L3: 16.704	0.954		
PR: +10% QC: +5%	L1: 18.317	L1: 17.508	L1: 16.700	0.933	214	9000
	L2: 18.327	L2: 17.489	L2: 16.696	0.932		
	L3: 18.332	L3: 17.494	L3: 16.704	0.933		
PR: +10% QC: 0%	L1: 18.317	L1: 16.674	L1: 16.700	0.911	213	9000
	L2: 18.327	L2: 16.657	L2: 16.696	0.910		
	L3: 18.332	L3: 16.661	L3: 16.704	0.910		
PR: +10% QC: -5%	L1: 18.317	L1: 15.840	L1: 16.700	0.888	197	9000
	L2: 18.327	L2: 15.824	L2: 16.696	0.887		
	L3: 18.332	L3: 15.828	L3: 16.704	0.887		
PR: +10% QC: -10%	L1: 18.317	L1: 15.007	L1: 16.700	0.864	174	9000
	L2: 18.327	L2: 14.991	L2: 16.696	0.863		
	L3: 18.332	L3: 14.995	L3: 16.704	0.863		

Power 66%						
Conditions	P _R [kW]	Q _L [kVar]	Q _C [kVar]	Q _f	Trip time [ms]	Limitation [ms]
P _R : 0% Q _C : -5%	L1: 11.100	L1: 10.528	L1: 11.113	0.974	212	9000
	L2: 11.083	L2: 10.541	L2: 11.122	0.977		
	L3: 11.091	L3: 10.545	L3: 11.109	0.976		
P _R : 0% Q _C : -4%	L1: 11.100	L1: 10.639	L1: 11.113	0.980	213	9000
	L2: 11.083	L2: 10.652	L2: 11.122	0.982		
	L3: 11.091	L3: 10.656	L3: 11.109	0.981		
P _R : 0% Q _C : -3%	L1: 11.100	L1: 10.750	L1: 11.113	0.985	218	9000
	L2: 11.083	L2: 10.763	L2: 11.122	0.987		
	L3: 11.091	L3: 10.767	L3: 11.109	0.986		
P _R : 0% Q _C : -2%	L1: 11.100	L1: 10.861	L1: 11.113	0.990	223	9000
	L2: 11.083	L2: 10.874	L2: 11.122	0.992		
	L3: 11.091	L3: 10.878	L3: 11.109	0.991		
P _R : 0% Q _C : -1%	L1: 11.100	L1: 10.972	L1: 11.113	0.995	227	9000
	L2: 11.083	L2: 10.985	L2: 11.122	0.997		
	L3: 11.091	L3: 10.989	L3: 11.109	0.996		
P _R : 0% Q _C : 0%	L1: 11.100	L1: 11.083	L1: 11.113	1.000	280	9000
	L2: 11.083	L2: 11.096	L2: 11.122	1.002		
	L3: 11.091	L3: 11.100	L3: 11.109	1.001		
P _R : 0% Q _C : +1%	L1: 11.100	L1: 11.193	L1: 11.113	1.005	262	9000
	L2: 11.083	L2: 11.207	L2: 11.122	1.007		
	L3: 11.091	L3: 11.211	L3: 11.109	1.006		
P _R : 0% Q _C : +2%	L1: 11.100	L1: 11.304	L1: 11.113	1.010	240	9000
	L2: 11.083	L2: 11.318	L2: 11.122	1.012		
	L3: 11.091	L3: 11.322	L3: 11.109	1.011		
P _R : 0% Q _C : +3%	L1: 11.100	L1: 11.415	L1: 11.113	1.015	210	9000
	L2: 11.083	L2: 11.429	L2: 11.122	1.017		
	L3: 11.091	L3: 11.433	L3: 11.109	1.016		
P _R : 0% Q _C : +4%	L1: 11.100	L1: 11.526	L1: 11.113	1.020	203	9000
	L2: 11.083	L2: 11.539	L2: 11.122	1.022		
	L3: 11.091	L3: 11.544	L3: 11.109	1.021		
P _R : 0% Q _C : +5%	L1: 11.100	L1: 11.637	L1: 11.113	1.024	196	9000
	L2: 11.083	L2: 11.650	L2: 11.122	1.027		
	L3: 11.091	L3: 11.655	L3: 11.109	1.026		

Power 33%						
Conditions	P _R [kW]	Q _L [kVar]	Q _C [kVar]	Q _f	Trip time [ms]	Limitation [ms]
P _R : 0% Q _c : -5%	L1: 5.552	L1: 5.295	L1: 5.548	0.976	216	9000
	L2: 5.557	L2: 5.287	L2: 5.552	0.975		
	L3: 5.548	L3: 5.279	L3: 5.543	0.975		
P _R : 0% Q _c : -4%	L1: 5.552	L1: 5.351	L1: 5.548	0.981	232	9000
	L2: 5.557	L2: 5.343	L2: 5.552	0.980		
	L3: 5.548	L3: 5.334	L3: 5.543	0.980		
P _R : 0% Q _c : -3%	L1: 5.552	L1: 5.407	L1: 5.548	0.986	242	9000
	L2: 5.557	L2: 5.398	L2: 5.552	0.985		
	L3: 5.548	L3: 5.390	L3: 5.543	0.985		
P _R : 0% Q _c : -2%	L1: 5.552	L1: 5.462	L1: 5.548	0.991	243	9000
	L2: 5.557	L2: 5.454	L2: 5.552	0.990		
	L3: 5.548	L3: 5.445	L3: 5.543	0.990		
P _R : 0% Q _c : -1%	L1: 5.552	L1: 5.518	L1: 5.548	0.997	280	9000
	L2: 5.557	L2: 5.510	L2: 5.552	0.995		
	L3: 5.548	L3: 5.501	L3: 5.543	0.995		
P _R : 0% Q _c : 0%	L1: 5.552	L1: 5.574	L1: 5.548	1.002	392	9000
	L2: 5.557	L2: 5.565	L2: 5.552	1.000		
	L3: 5.548	L3: 5.557	L3: 5.543	1.000		
P _R : 0% Q _c : +1%	L1: 5.552	L1: 5.630	L1: 5.548	1.007	342	9000
	L2: 5.557	L2: 5.621	L2: 5.552	1.005		
	L3: 5.548	L3: 5.612	L3: 5.543	1.005		
P _R : 0% Q _c : +2%	L1: 5.552	L1: 5.685	L1: 5.548	1.012	284	9000
	L2: 5.557	L2: 5.677	L2: 5.552	1.010		
	L3: 5.548	L3: 5.668	L3: 5.543	1.010		
P _R : 0% Q _c : +3%	L1: 5.552	L1: 5.741	L1: 5.548	1.016	236	9000
	L2: 5.557	L2: 5.732	L2: 5.552	1.015		
	L3: 5.548	L3: 5.723	L3: 5.543	1.015		
P _R : 0% Q _c : +4%	L1: 5.552	L1: 5.797	L1: 5.548	1.021	202	9000
	L2: 5.557	L2: 5.788	L2: 5.552	1.020		
	L3: 5.548	L3: 5.779	L3: 5.543	1.020		
P _R : 0% Q _c : +5%	L1: 5.552	L1: 5.853	L1: 5.548	1.026	191	9000
	L2: 5.557	L2: 5.843	L2: 5.552	1.025		
	L3: 5.548	L3: 5.834	L3: 5.543	1.025		

Prüfbericht-Nr.: CN25NMLN 001 Attachment 1
 Test report no.:

Seite 41 von 172
 Page 41 of 172

5.6	TABLE: Connection conditions and synchronization (Reconnection)			P
Condition	Measurement		Limitation	
	Reconnection	Delay time [s]	Reconnection	Delay time [s]
f<47.45Hz	No	123	No	≥60
f≥47.55Hz	Yes	62	Yes	≥60
f>50.15Hz	No	125	No	≥60
f≤50.05Hz	Yes	64	Yes	≥60
U<0.84Un	No	130	No	≥60
U≥0.86Un	Yes	66	Yes	≥60
U>1.11Un	No	129	No	≥60
U≤1.09Un	Yes	67	Yes	≥60
Note(s):				

Prüfbericht-Nr.: CN25NMLN 001 Attachment 1 <i>Test report no.:</i>	Seite 42 von 172 Page 42 of 172
--	------------------------------------

5.7	TABLE: P _{AV,E} monitoring	P
P _{AV,E} value setting: 60% P _n		
Power limit method		
Test method	Condition	
Jump of primary energy	P _{rim} / P _{dc,r} : 60%->100%	
Cut of load	P _{load} /P _n : 40%->0%	

Power curve:

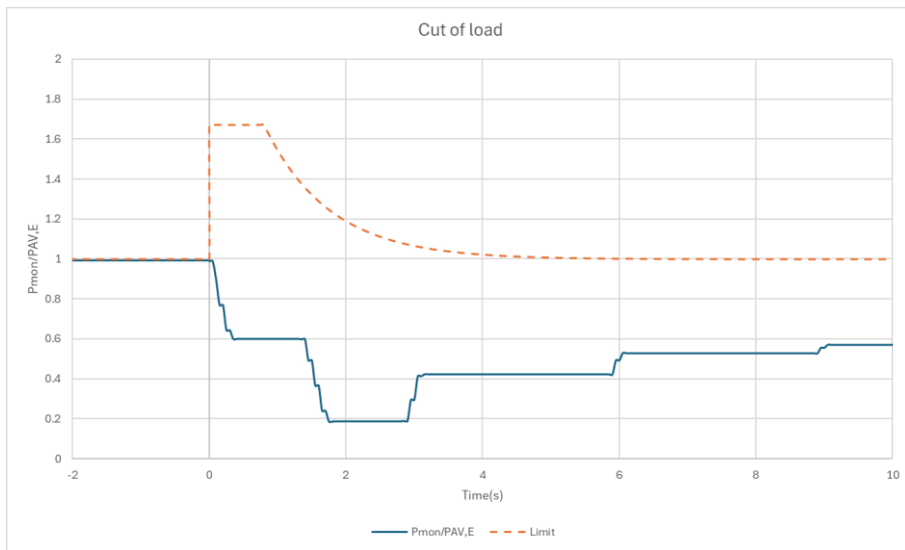
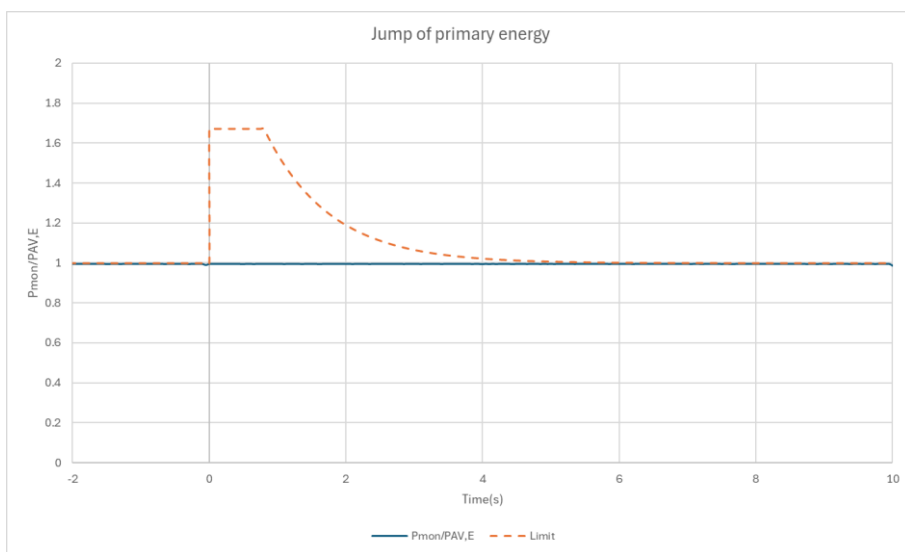

Disconnection method		
Condition	Trip time [ms]	
	Measurement	Limitation
0.98* P _{AV,E}	--	No disconnect
1.02 P _{AV,E} -1.067* P _{AV,E}	--	< 10000+200
1.067 P _{AV,E} -1.670* P _{AV,E}	--	< 3000 + 200
1.690* P _{AV,E}	--	< 200

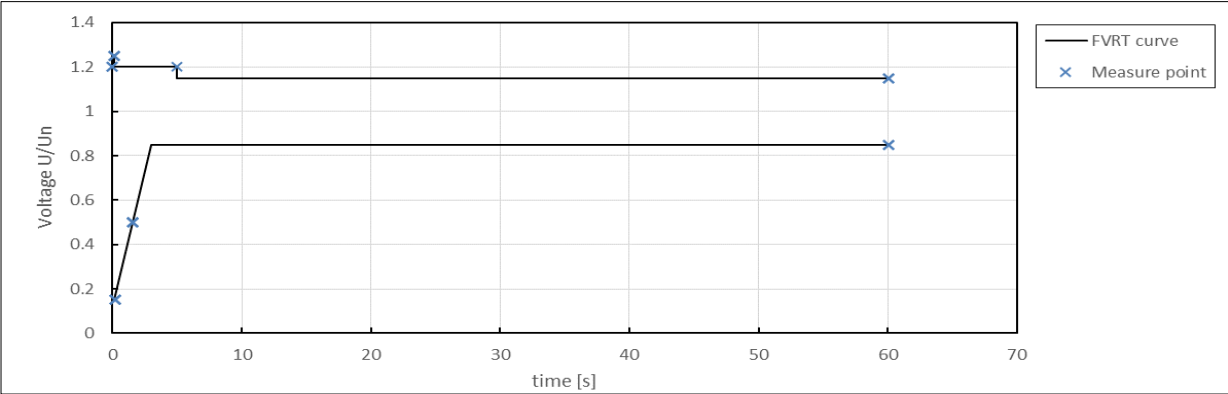
5.8	TABLE: Verification of dynamic network supporting (FVRT)	P
FRT curve settings: <div style="text-align: center; margin-top: 10px;">  </div>		
Fault Type	3-phase fault and 2-phase fault	
Transformer Type	Dy5	
NS protection settings	See table 5.5.7 for detail.	
Any auxilliary power supply in fault ride through?	Yes/No	
Terminal sequence	For D1: U-L1, V-L2, W-L3 For D2: U-L3, V-L1, W-L2	

D1	Test Equipment	Test Sample
Connection terminal	U	L1
	V	L2
	W	L3 (L for single phase)
D2	Test Equipment	Test Sample
Connection terminal	U	L3
	V	L1 (L for single phase)
	W	L2

Prüfbericht-Nr.: CN25NMLN 001 Attachment 1
 Test report no.:

Seite 44 von 172
 Page 44 of 172

Test	U/Un [p.u.]	Fault type	Fault duration [ms]	P/Pn [p.u.]	Q/Pn [p.u.]	Test No.
1	0.15.....0.25	A	For 0.15pu ≥ 150 For 0.25pu ≥ 500	1.0	0...±0.1	1.1
				0.2...0.6		1.2
		D1		1.0		1.3
				0.2...0.6		1.4
		D2		1.0		1.3 (D2)
		2		0.50....0.60		A
0.2...0.6	2.2					
D1	1.0		2.3			
	0.2...0.6		2.4			
3	0.50....0.60	A	For 0.5pu ≥ 1500 For 0.60pu ≥ 2000	1.0	Max. under-excited	3.1
				0.2...0.6		3.2
		D1		1.0		3.3
				0.2...0.6		3.4
4	0.85....0.90	A	≥ 60000	1.0	0...±0.1	4.1
				0.2...0.6		4.2
		D1		1.0		4.3
				0.2...0.6		4.4
5	1.2....1.25	A	≥ 100	1.0	0...±0.1	5.1
				0.2...0.6		5.2
		D1		1.0		5.3
				0.2...0.6		5.4
		D2		1.0		5.3 (D2)
6	1.15...1.20	A	≥ 5000	1.0	0...±0.1	6.1
				0.2...0.6		6.2
		D1		1.0		6.3
				0.2...0.6		6.4
7	1.10...1.15	A	≥ 60000	1.0	0...±0.1	7.1
				0.2...0.6		7.2
		D1		1.0		7.3
				0.2...0.6		7.4

Condition						Measurement
No.	Parameter	Phase ref.	Time ref.	unit		
General Info.	0	Test number	--	--	--	1.1
	1	Date	--	--	dd.mm.yyyy	15.05.2025
	2	Time (start of test)	--	--	hh:mm:ss	09:59:48
	3	Fault type (phase)	--	--		A
	4	Setting voltage depth	Line to line	--	p.u.	0.15
	5	Setting dip duration		--		150
	6	Point of fault entry	Total	--	ms	19242
	7	Point of fault clearance	Total	--	ms	19401
	8	Fault duration in empty load test	Total	--	ms	160
	9	Voltage depth/height in empty load test	Total	t1+100ms to t2 and t1-10s to t1	p.u.	0.151
10	Pos.		p.u.		1.000	
Before dip <t1	11	Voltage	Line to neutral	t1-100s to t1	p.u.	1.009
	12	Current	Pos.	t1-500ms to t1-100ms	p.u.	1.001
	13	Active power	Total	t1-10s to t1	p.u.	1.010
	14		Pos.			1.010
	15	Reactive power	Total	t1-10s to t1	p.u.	0.012
	16		Pos.			0.004
17	Cos ϕ	--	t1-10s to t1	--	0.999	
During dip t1 to t2	18	Voltage	Line to neutral	t1+100ms to t2-20ms	p.u.	0.151
	19	Line current	Phase 1	t1+60ms	p.u.	0.011
	20		Phase 2			0.013
	21		Phase 3			0.022
	22	Line current	Phase 1	t1+100ms	p.u.	0.021
	23		Phase 2			0.020
	24		Phase 3			0.014
	25	Active power	Total	t1+100ms to t2-20ms	p.u.	0.003
26	Pos.		0.003			
After dip > t2	27	Voltage	Line to neutral	t2+3s to t2+10s	p.u.	1.009
	28	Active power	Total	t2+3s to t2+10s	p.u.	1.011
	29		Pos.			1.010
	39	Active power rising time	Pos.	--	s	0.401
	31	Reactive power	Total	t2+3s to t2+10s	p.u.	0.032
	32		Pos.			0.001
	33	Reactive power rising time	Pos.	--	s	--
	34	PGU does not disconnect from grid till 60s after fault	--	t2 to t2+60s	Yes / No	Yes

Test No. 1.1 idle test



	A	B	Delta	RMS
Time [s]	0:19:279800	0:19:440000	0:160200	
AI 1/U1 [V]	-271.4129	-40.17449	231.2384	42.24883
AI 1/U2 [V]	-18.08214	-4.039526	14.04262	43.44770
AI 1/U3 [V]	289.2926	43.78891	-245.5037	56.16540
AI 1/I1 [A]	0.443662	-3.096854	-3.540516	7.036650
AI 1/I2 [A]	-0.104936	6.058185	6.163121	6.677274
AI 1/I3 [A]	-0.216838	-2.851361	-2.634525	6.050536
U1_IRMS@POWER/0 [V]	230.0038	34.85161	-195.1522	112.2266
U2_IRMS@POWER/0 [V]	229.9302	34.73226	-195.1980	112.4501
U3_IRMS@POWER/0 [V]	229.9259	34.70388	-195.2220	112.4513
I1_IRMS_rc@POWER/0 [A]	0.480590	4.091115	3.610526	6.997304
I2_IRMS_rc@POWER/0 [A]	0.487880	3.903387	3.415507	6.630583
I3_IRMS_rc@POWER/0 [A]	0.482007	4.024258	3.542251	5.973994
P_t_rc@POWER/0 [W]	-20.36963	-54.19457	-33.82594	370.8301
P_fund_SYM_rc@POWER/0 [W]	-21.37666	-53.32059	-31.94393	1049.889
Q_t_rc@POWER/0 [var]	-332.6787	414.0325	746.9112	2161.755
Q_fund_SYM_rc@POWER/0 [var]	-40.68301	403.4713	444.1543	363.7169

Test No. 1.1 with PGU

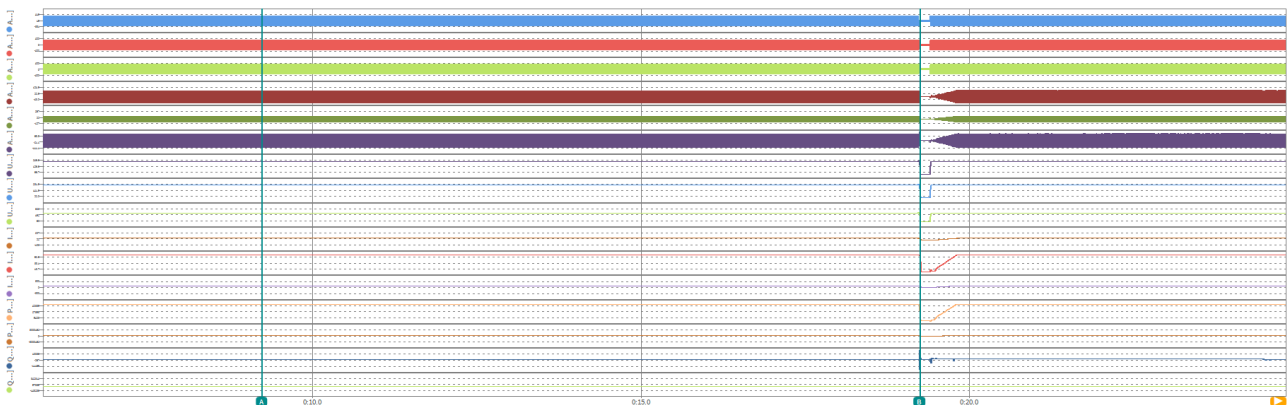

	A	B	Delta	RMS
Time [s]	9.230443	0:19:243729	0:10:004286	
AI 1/U1 [V]	-244.3643	32.59230	276.9566	230.9437
AI 1/U2 [V]	-96.95956	-47.87890	49.08066	236.8159
AI 1/U3 [V]	308.4617	14.38499	-294.0767	230.8549
AI 1/I1 [A]	-77.63414	62.79525	140.4294	72.84953
AI 1/I2 [A]	-18.41477	-86.01502	-67.60025	73.29770
AI 1/I3 [A]	96.21109	23.30316	-72.90793	72.93017
U1_IRMS_rc@POWER/0 [V]	230.9823	231.1088	0.126450	230.9801
U2_IRMS_rc@POWER/0 [V]	230.8493	222.8558	-8.993799	236.8381
U3_IRMS_rc@POWER/0 [V]	230.8472	225.8469	-5.000244	230.8416
I1_IRMS_rc@POWER/0 [A]	72.92003	73.04758	0.127571	72.85496
I2_IRMS_rc@POWER/0 [A]	73.31457	74.02856	0.713989	73.29559
I3_IRMS_rc@POWER/0 [A]	72.90926	73.47150	0.562248	72.92139
P_t_rc@POWER/0 [W]	50592.79	49056.89	-1535.898	50575.31
P_fund_SYM_rc@POWER/0 [W]	50585.75	49119.43	-1470.316	50572.23
Q_t_rc@POWER/0 [var]	761.0438	928.182	167.138	741.4039
Q_fund_SYM_rc@POWER/0 [var]	434.8336	284.5392	-140.2945	397.2170

t1-10s to t1

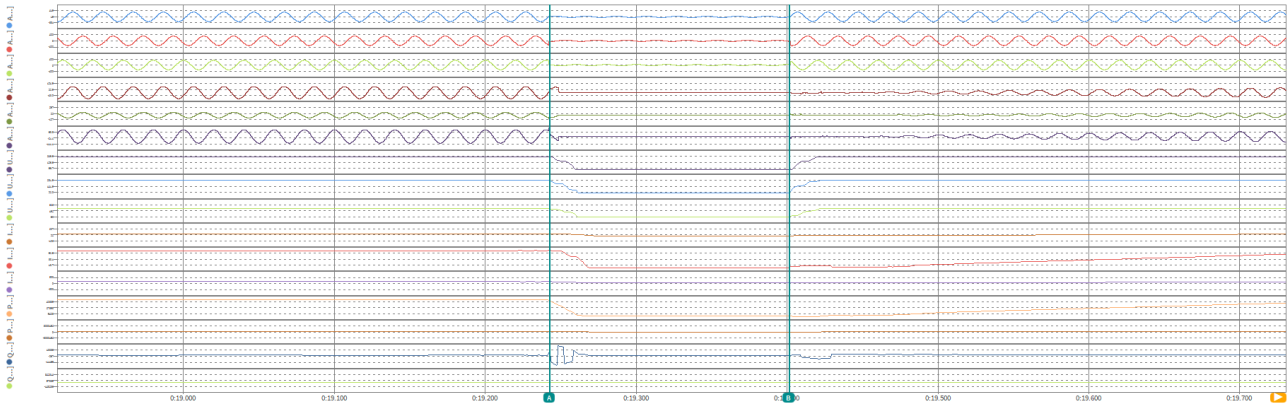

Time [s]	A	B	Delta	RMS
AI 1/U1 [V]	27.51637	-12.27665	-39.79302	34.21385
AI 1/U2 [V]	-48.62070	-33.87809	14.74261	33.73982
AI 1/U3 [V]	23.01359	46.01217	22.99857	33.69732
AI 1/I1 [A]	24.94377	-0.20845	-25.15222	15.67285
AI 1/I2 [A]	-118.0942	1.057117	119.1514	13.66257
AI 1/I3 [A]	93.19903	-0.769132	-93.96816	7.589217
U1_IRMS_rc@POWER0 [V]	229.2730	34.45049	-194.8225	67.43715
U2_IRMS_rc@POWER0 [V]	231.5661	34.07177	-197.4943	64.80364
U3_IRMS_rc@POWER0 [V]	231.8113	33.66137	-198.1499	71.35246
I1_IRMS_rc@POWER0 [A]	72.22080	1.125771	-71.10703	24.29465
I2_IRMS_rc@POWER0 [A]	73.40146	1.171778	-72.22968	21.53302
I3_IRMS_rc@POWER0 [A]	73.20629	1.146622	-72.05967	22.19281
P_t_rc@POWER0 [W]	50544.36	-18.39274	-50562.76	11329.14
P_fund_SYM+rc@POWER0 [W]	50507.61	-19.99427	-50527.61	10718.49
Q_t_rc@POWER0 [var]	699.9696	115.8538	-584.1160	4686.461
Q_fund_SYM+rc@POWER0 [var]	355.2730	18.80032	-336.4727	89.98257

t1 to t2

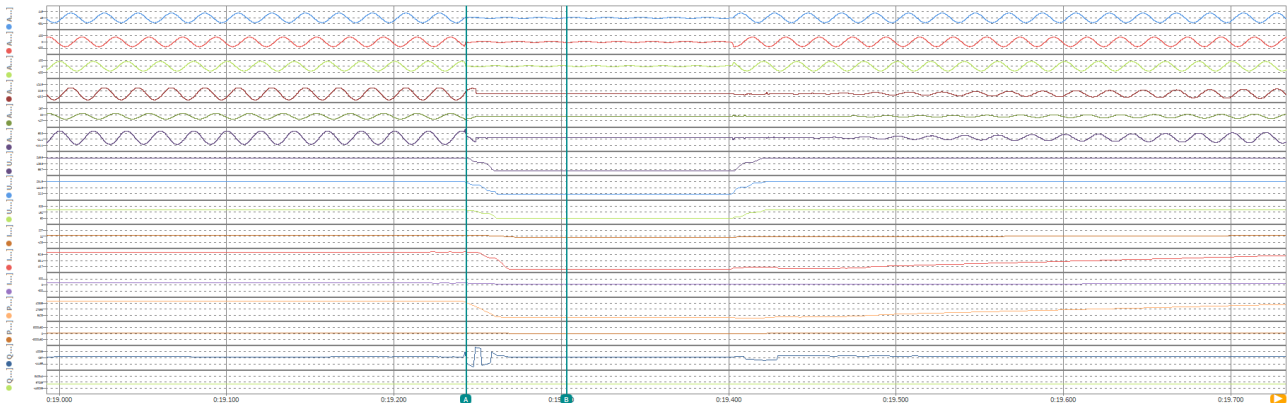

Time [s]	A	B	Delta	RMS
AI 1/U1 [V]	29.74177	16.71743	-13.02433	33.90743
AI 1/U2 [V]	-42.58609	-47.37163	-4.785538	33.64747
AI 1/U3 [V]	13.26656	30.75457	17.48800	33.65711
AI 1/I1 [A]	50.02241	-0.128066	-50.21048	25.13393
AI 1/I2 [A]	-85.29691	1.540868	86.83777	20.10249
AI 1/I3 [A]	35.27904	-1.324528	-36.60357	11.31517
U1_IRMS_rc@POWER0 [V]	231.1088	33.90415	-197.1146	95.91432
U2_IRMS_rc@POWER0 [V]	222.3553	33.84507	-188.5103	91.00399
U3_IRMS_rc@POWER0 [V]	225.9469	33.86456	-192.0824	103.0764
I1_IRMS_rc@POWER0 [A]	73.04758	1.034006	-72.01297	38.19740
I2_IRMS_rc@POWER0 [A]	74.02856	0.667714	-73.36084	36.26992
I3_IRMS_rc@POWER0 [A]	73.47150	1.166542	-72.30496	34.67454
P_t_rc@POWER0 [W]	49056.89	-71.74325	-49128.63	17168.91
P_fund_SYM+rc@POWER0 [W]	49119.43	-72.00271	-49191.43	16109.58
Q_t_rc@POWER0 [var]	8038.182	65.68937	-8063.869	7686.217
Q_fund_SYM+rc@POWER0 [var]	284.5392	16.33181	-278.2074	136.3185

t1+60ms

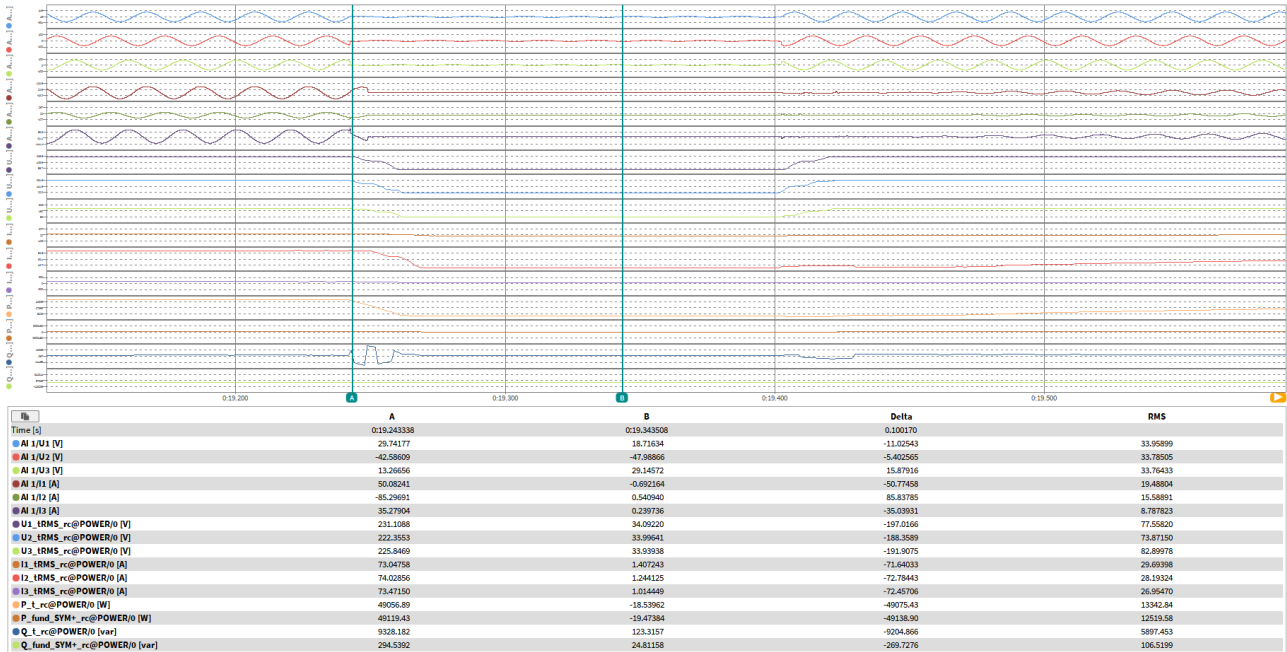

t1+100ms

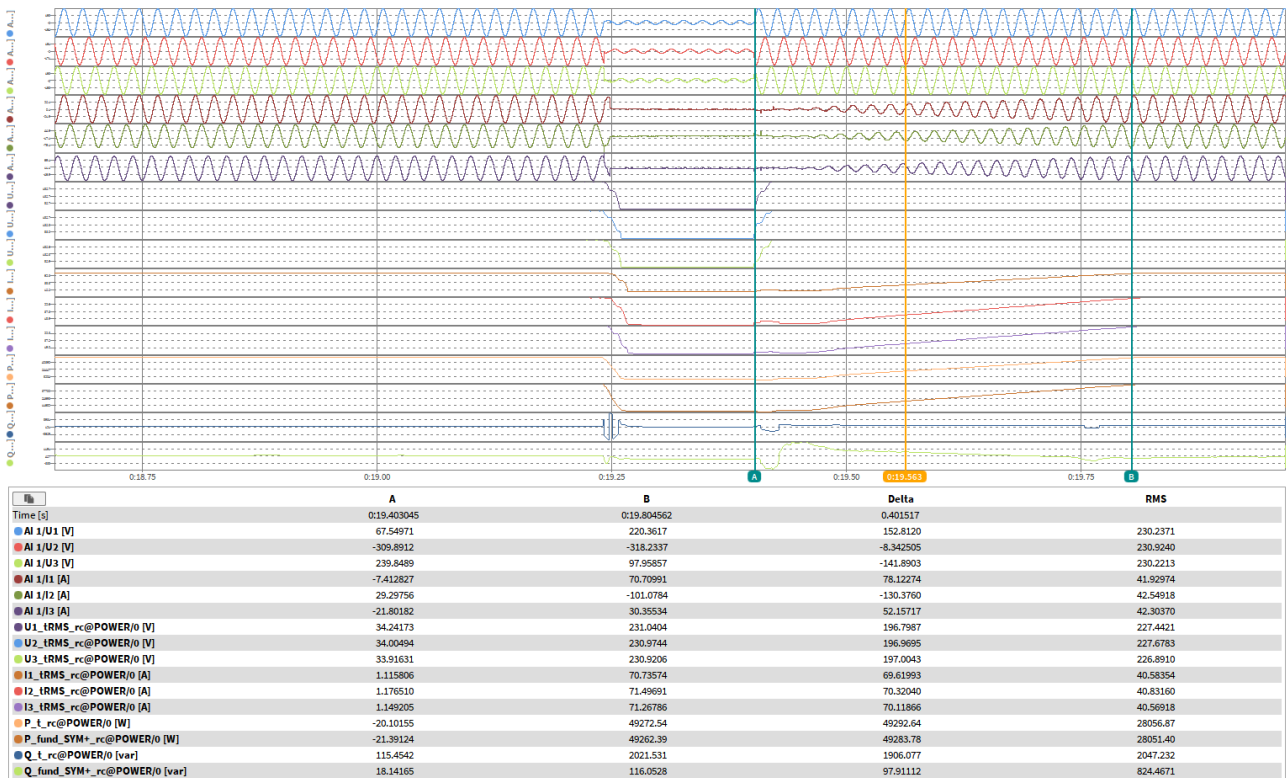

Active power rising time

Condition						Measurement
No.	Parameter	Phase ref.	Time ref.	unit		
General Info.	0	Test number	--	--	--	1.2
	1	Date	--	--	dd.mm.yyyy	13.06.2025
	2	Time (start of test)	--	--	hh:mm:ss.f	15:41:08
	3	Fault type (phase)	--	--		A
	4	Setting voltage depth	Line to line	--	p.u.	0.15
	5	Setting dip duration		--		150
	6	Point of fault entry	Total	--	ms	19442
	7	Point of fault clearance	Total	--	ms	19602
	8	Fault duration in empty load test	Total	--	ms	160
	9	Voltage depth/height in empty load test	Total	t1+100ms to t2 and t1-10s to t1	p.u.	0.151
10	Pos.		p.u.		1.000	
Before dip <t1	11	Voltage	Line to neutral	t1-100s to t1	p.u.	1.001
	12	Current	Pos.	t1-500ms to t1-100ms	p.u.	0.500
	13	Active power	Total	t1-10s to t1	p.u.	0.499
	14		Pos.			0.499
	15	Reactive power	Total	t1-10s to t1	p.u.	0.006
	16		Pos.			0.001
17	Cos ϕ	--	t1-10s to t1	--	0.999	
During dip t1 to t2	18	Voltage	Line to neutral	t1+100ms to t2-20ms	p.u.	0.149
	19	Line current	Phase 1	t1+60ms	p.u.	0.017
	20		Phase 2			0.016
	21		Phase 3			0.010
	22	Line current	Phase 1	t1+100ms	p.u.	0.028
	23		Phase 2			0.022
	24		Phase 3			0.012
	25	Active power	Total	t1+100ms to t2-20ms	p.u.	0.009
26	Pos.		0.009			
After dip > t2	27	Voltage	Line to neutral	t2+3s to t2+10s	p.u.	1.001
	28	Active power	Total	t2+3s to t2+10s	p.u.	0.499
	29		Pos.			0.499
	39	Active power rising time	Pos.	--	s	0.224
	31	Reactive power	Total	t2+3s to t2+10s	p.u.	0.008
	32		Pos.			0.004
	33	Reactive power rising time	Pos.	--	s	--
	34	PGU does not disconnect from grid till 60s after fault	--	t2 to t2+60s	Yes / No	Yes

Test No. 1.2 idle test



	A	B	Delta	RMS
Time [s]	0:19.279800	0:19.440000	0.160200	
AI 1/U1 [V]	-271.4129	-40.17449	231.2384	42.24883
AI 1/U2 [V]	-18.08214	-4.039526	14.04262	43.44770
AI 1/U3 [V]	289.2926	43.78891	-245.5037	56.16540
AI 1/I1 [A]	0.443662	-3.096854	-3.540516	7.036650
AI 1/I2 [A]	-0.104936	6.058185	6.163121	6.677274
AI 1/I3 [A]	-0.216836	-2.851361	-2.634525	6.050536
U1_IRMS@POWER/0 [V]	230.0038	34.85161	-195.1522	112.2266
U2_IRMS@POWER/0 [V]	229.9302	34.73226	-195.1980	112.4501
U3_IRMS@POWER/0 [V]	229.9259	34.70388	-195.2220	112.4513
I1_IRMS_rc@POWER/0 [A]	0.480590	4.091115	3.610526	6.997394
I2_IRMS_rc@POWER/0 [A]	0.487880	3.903387	3.415507	6.630583
I3_IRMS_rc@POWER/0 [A]	0.482007	4.024258	3.542251	5.973994
P_t_rc@POWER/0 [W]	-20.36963	-54.19457	-33.82594	370.8301
P_fund_SYM_rc@POWER/0 [W]	-21.37666	-53.32059	-31.94393	1049.889
Q_t_rc@POWER/0 [var]	-332.6787	414.0325	746.9112	2161.755
Q_fund_SYM_rc@POWER/0 [var]	-40.68301	403.4713	444.1543	363.7169

Test No. 1.2 with PGU



	A	B	Delta	RMS
Time [s]	9.431987	0:19.441166	0:10.009179	
AI 1/U1 [V]	29.17361	-118.5422	-147.7158	230.6657
AI 1/U2 [V]	265.4951	-203.7826	-469.2776	230.3893
AI 1/U3 [V]	-296.6128	321.9090	618.5217	230.4020
AI 1/I1 [A]	4.401411	-19.10666	-23.50807	36.18052
AI 1/I2 [A]	42.41702	-31.26625	-73.68327	36.13624
AI 1/I3 [A]	-46.73230	50.48288	97.21518	36.15282
U1_IRMS@POWER/0 [V]	230.6515	230.6692	0.017731	230.6577
U2_IRMS@POWER/0 [V]	230.3810	230.3921	0.011093	230.3898
U3_IRMS@POWER/0 [V]	230.4079	230.4048	-3.067e-3	230.4094
I1_IRMS_rc@POWER/0 [A]	36.18189	36.06420	-0.117691	36.17942
I2_IRMS_rc@POWER/0 [A]	36.12372	35.99712	-0.126598	36.13627
I3_IRMS_rc@POWER/0 [A]	36.14528	36.42714	0.281857	36.15400
P_t_rc@POWER/0 [W]	24993.72	25003.26	9.535156	24998.40
P_fund_SYM_rc@POWER/0 [W]	24992.77	24981.77	-11.00000	24997.38
Q_t_rc@POWER/0 [var]	-337.8857	-336.2055	1.680145	340.2174
Q_fund_SYM_rc@POWER/0 [var]	-12.15965	-13.89419	-1.734538	17.80276

t1-10s to t1

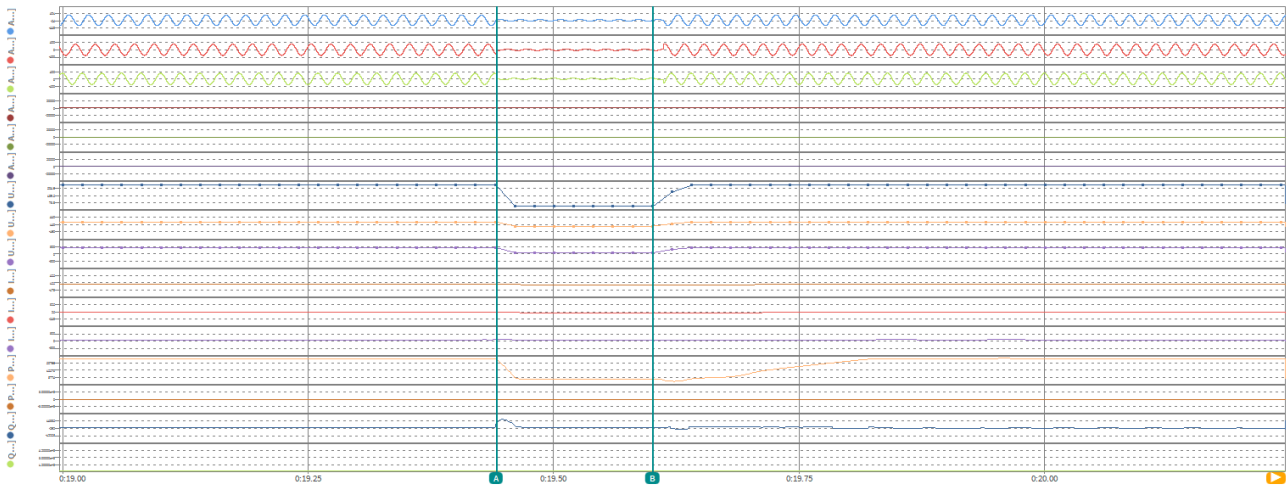

	A	B	Delta	RMS
Time [s]	0:19:442270	0:19:601569	0:159300	
AI 1/U1 [V]	-3.638506	-11.74021	-8.101702	34.45171
AI 1/U2 [V]	-277.8776	-34.18493	243.6927	36.23154
AI 1/U3 [V]	283.5279	45.70627	-237.8216	36.15181
AI 1/I1 [A]	0.932420	-0.140464	-1.072884	14.62673
AI 1/I2 [A]	-44.20045	1.254050	45.45450	14.29594
AI 1/I3 [A]	43.41377	-1.003617	-44.41738	10.57603
U1_IRMS@POWER/0 [V]	230.6693	34.37724	-196.2921	112.4875
U2_IRMS@POWER/0 [V]	230.3921	34.23297	-196.1591	112.7457
U3_IRMS@POWER/0 [V]	230.4047	34.21494	-196.1898	112.7334
I1_IRMS_rc@POWER/0 [A]	35.92663	1.242045	-34.68458	17.39477
I2_IRMS_rc@POWER/0 [A]	36.20372	1.219530	-34.98419	16.74351
I3_IRMS_rc@POWER/0 [A]	36.36095	0.678227	-35.68272	14.48546
P_t_rc@POWER/0 [W]	25004.00	-44.29202	-25048.29	5999.398
P_fund_SYM+rc@POWER/0 [W]	24985.53	-44.64821	-25030.17	6446.819
Q_t_rc@POWER/0 [var]	-337.9417	98.16472	436.1064	4763.670
Q_fund_SYM+rc@POWER/0 [var]	-9.926939	20.84923	30.77617	241.0943

t1 to t2

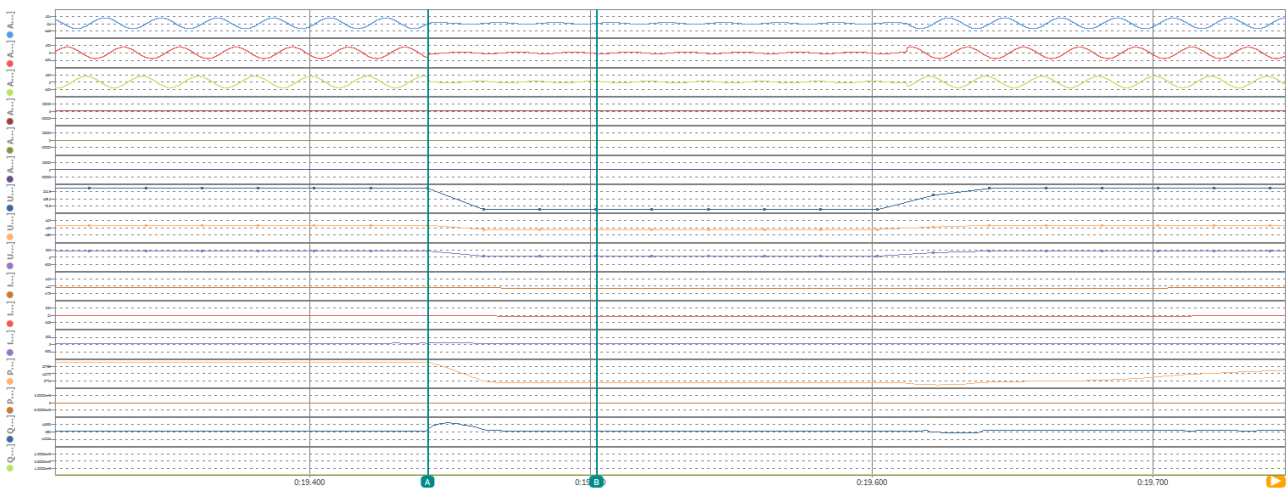

	A	B	Delta	RMS
Time [s]	0:19:442270	0:19:502296	0:060026	
AI 1/U1 [V]	-3.638506	-2.880573	0.757933	34.44232
AI 1/U2 [V]	-277.8776	-40.57837	237.2992	39.40140
AI 1/U3 [V]	283.5279	42.77349	-240.7544	39.29129
AI 1/I1 [A]	0.932420	-1.046454	-1.978874	23.71127
AI 1/I2 [A]	-44.20045	1.831776	46.03863	23.20411
AI 1/I3 [A]	43.41377	-0.693673	-44.10744	17.18025
U1_IRMS@POWER/0 [V]	230.6693	34.28511	-196.3842	164.3123
U2_IRMS@POWER/0 [V]	230.3921	34.12015	-196.2719	164.7479
U3_IRMS@POWER/0 [V]	230.4047	34.22112	-196.1836	164.7249
I1_IRMS_rc@POWER/0 [A]	35.92663	1.294193	-34.63244	28.08007
I2_IRMS_rc@POWER/0 [A]	36.20372	1.169640	-35.03408	27.04953
I3_IRMS_rc@POWER/0 [A]	36.36095	0.731179	-35.62977	23.43536
P_t_rc@POWER/0 [W]	25004.00	-17.45268	-25021.45	9716.170
P_fund_SYM+rc@POWER/0 [W]	24985.53	-17.77343	-25003.30	10440.80
Q_t_rc@POWER/0 [var]	-337.9417	107.8024	445.7441	7713.132
Q_fund_SYM+rc@POWER/0 [var]	-9.926939	24.61247	34.53941	389.0717

t1+60ms

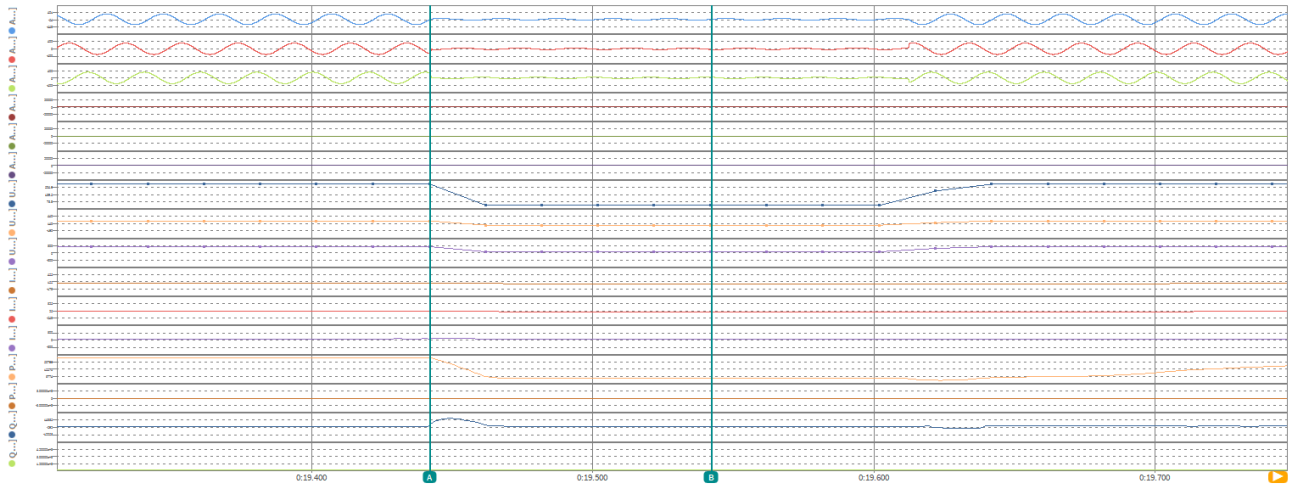

	A	B	Delta	RMS
Time [s]	0:19:442270	0:19:542304	0:100035	
AI 1/U1 [V]	-3.638506	-1.918793	1.719713	34.36682
AI 1/U2 [V]	-277.8776	-41.31747	236.5601	37.39709
AI 1/U3 [V]	283.5279	42.25397	-241.2739	37.33205
AI 1/I1 [A]	0.932420	-1.213347	-2.145767	18.40826
AI 1/I2 [A]	-44.20045	2.124278	46.32473	17.99950
AI 1/I3 [A]	43.41377	-0.789040	-44.20281	13.32616
U1_IRMS@POWER/0 [V]	230.6693	34.32503	-196.3443	126.2193
U2_IRMS@POWER/0 [V]	230.3921	34.16818	-196.2239	126.5265
U3_IRMS@POWER/0 [V]	230.4047	34.16882	-196.2359	126.5135
I1_IRMS@POWER/0 [A]	35.92663	2.046512	-33.88012	21.85631
I2_IRMS@POWER/0 [A]	36.20372	1.642917	-34.56080	21.04456
I3_IRMS@POWER/0 [A]	36.36095	0.905666	-35.45528	18.22141
P_t_rc@POWER/0 [W]	25004.00	-45.21682	-25049.22	7550.976
P_fund_SYM+rc@POWER/0 [W]	24985.53	-45.83137	-25031.36	8114.119
Q_t_rc@POWER/0 [var]	-337.9417	150.6806	488.6223	5994.914
Q_fund_SYM+rc@POWER/0 [var]	-9.926939	27.10309	37.03003	302.8783

t1+100ms

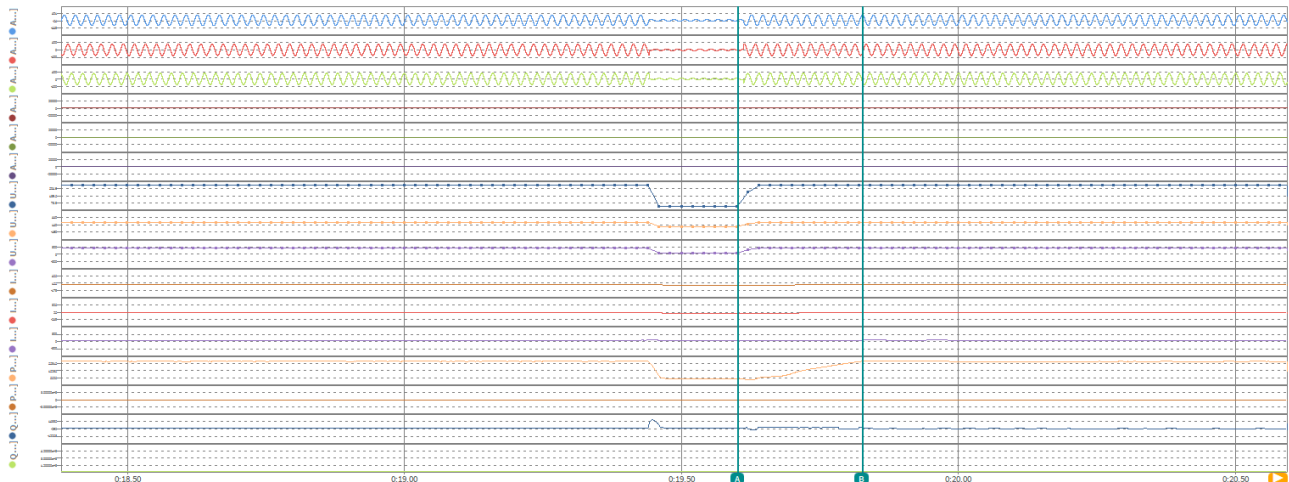

	A	B	Delta	RMS
Time [s]	0:19:526026	0:20:022427	0:224227	
AI 1/U1 [V]	-3.296418	298.7213	308.0177	224.3712
AI 1/U2 [V]	-36.09157	-261.7610	-225.6694	226.2696
AI 1/U3 [V]	45.10165	-38.42569	-83.52733	223.7548
AI 1/I1 [A]	-0.116622	47.00681	47.12343	21.11082
AI 1/I2 [A]	1.468627	-43.21102	-44.67964	21.48543
AI 1/I3 [A]	-1.242036	-3.673905	-2.431870	21.17729
U1_IRMS@POWER/0 [V]	34.37724	230.6905	196.3133	207.6178
U2_IRMS@POWER/0 [V]	34.23297	230.5169	196.2839	207.3532
U3_IRMS@POWER/0 [V]	34.21494	230.5007	196.2858	207.3374
I1_IRMS@POWER/0 [A]	1.242045	36.10646	34.86442	19.80070
I2_IRMS@POWER/0 [A]	1.219530	36.25050	35.03097	19.84540
I3_IRMS@POWER/0 [A]	0.678227	36.17408	35.49586	19.79048
P_t_rc@POWER/0 [W]	-44.29202	24993.01	25037.30	13583.39
P_fund_SYM+rc@POWER/0 [W]	-44.64821	24990.46	25035.11	13577.46
Q_t_rc@POWER/0 [var]	98.16472	1232.345	1134.180	1555.109
Q_fund_SYM+rc@POWER/0 [var]	20.84923	19.48932	-1.359911	478.0339

Active power rising time

Condition						Measurement
No.	Parameter	Phase ref.	Time ref.	unit		
General Info.	0	Test number	--	--	--	1.3
	1	Date	--	--	dd.mm.yyyy	26.06.2025
	2	Time (start of test)	--	--	hh:mm:ss.f	15:06:08
	3	Fault type (phase)	--	--		D1
	4	Setting voltage depth	Line to line	--	p.u.	0.15
	5	Setting dip duration		--		150
	6	Point of fault entry	Total	--	ms	36621
	7	Point of fault clearance	Total	--	ms	36797
	8	Fault duration in empty load test	Total	--	ms	161
	9	Voltage depth/height in empty load test	Total	t1+100ms to t2 and t1-10s to t1	p.u.	0.150
10	Pos.		p.u.		0.999	
Before dip <t1	11	Voltage	Line to neutral	t1-100s to t1	p.u.	1.004
	12	Current	Pos.	t1-500ms to t1-100ms	p.u.	1.006
	13	Active power	Total	t1-10s to t1	p.u.	1.008
	14		Pos.			1.008
	15	Reactive power	Total	t1-10s to t1	p.u.	0.012
	16		Pos.			0.006
17	Cosφ	--	t1-10s to t1	--	0.999	
During dip t1 to t2	18	Voltage	Line to neutral	t1+100ms to t2-20ms	p.u.	0.148
	19	Line current	Phase 1	t1+60ms	p.u.	0.051
	20		Phase 2			0.053
	21		Phase 3			0.047
	22	Line current	Phase 1	t1+100ms	p.u.	0.025
	23		Phase 2			0.025
	24		Phase 3			0.024
	25	Active power	Total	t1+100ms to t2-20ms	p.u.	0.001
26	Pos.		0.001			
After dip > t2	27	Voltage	Line to neutral	t2+3s to t2+10s	p.u.	1.004
	28	Active power	Total	t2+3s to t2+10s	p.u.	1.008
	29		Pos.			1.008
	39	Active power rising time	Pos.	--	s	0.484
	31	Reactive power	Total	t2+3s to t2+10s	p.u.	0.011
	32		Pos.			0.006
	33	Reactive power rising time	Pos.	--	s	--
	34	PGU does not disconnect from grid till 60s after fault	--	t2 to t2+60s	Yes / No	Yes

Test No. 1.3 idle test

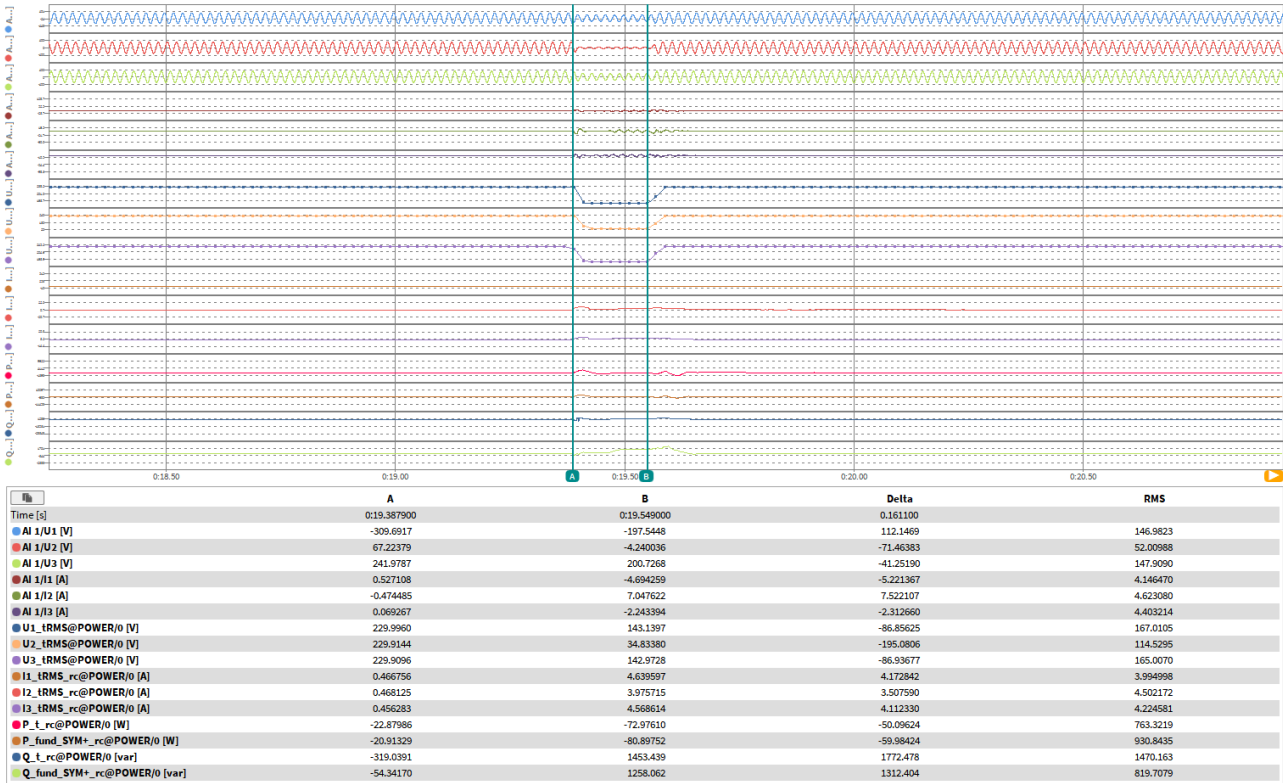

Test No. 1.3 with PGU

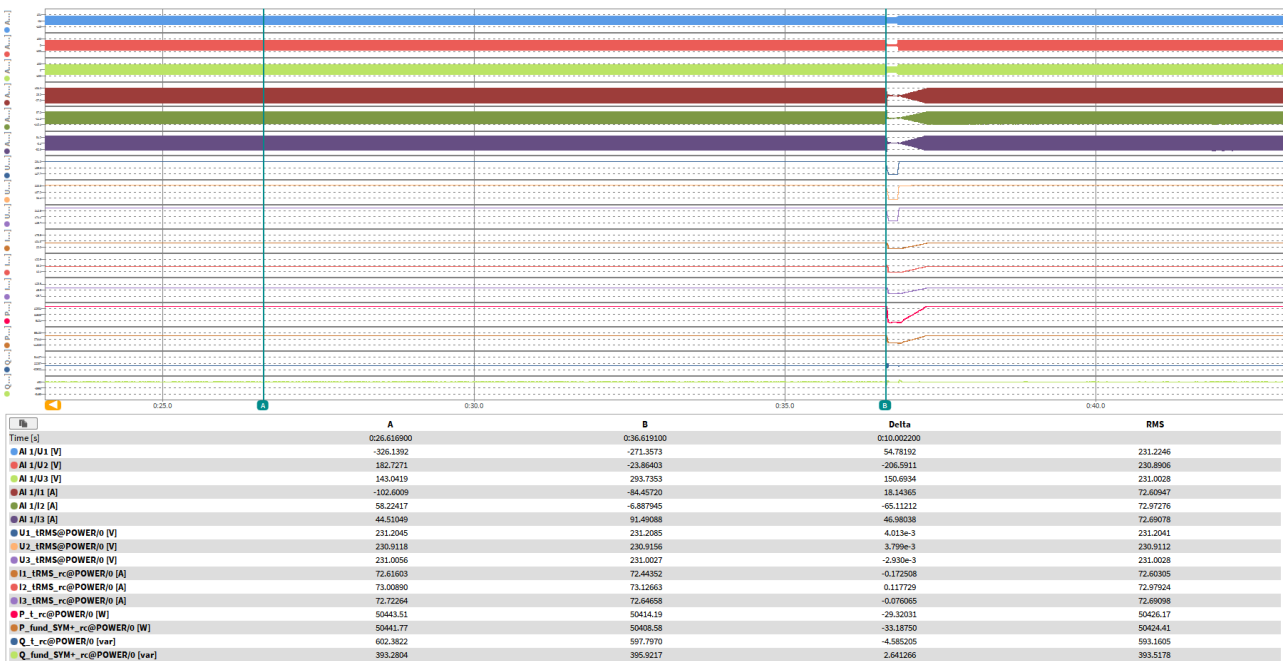

t1-10s to t1

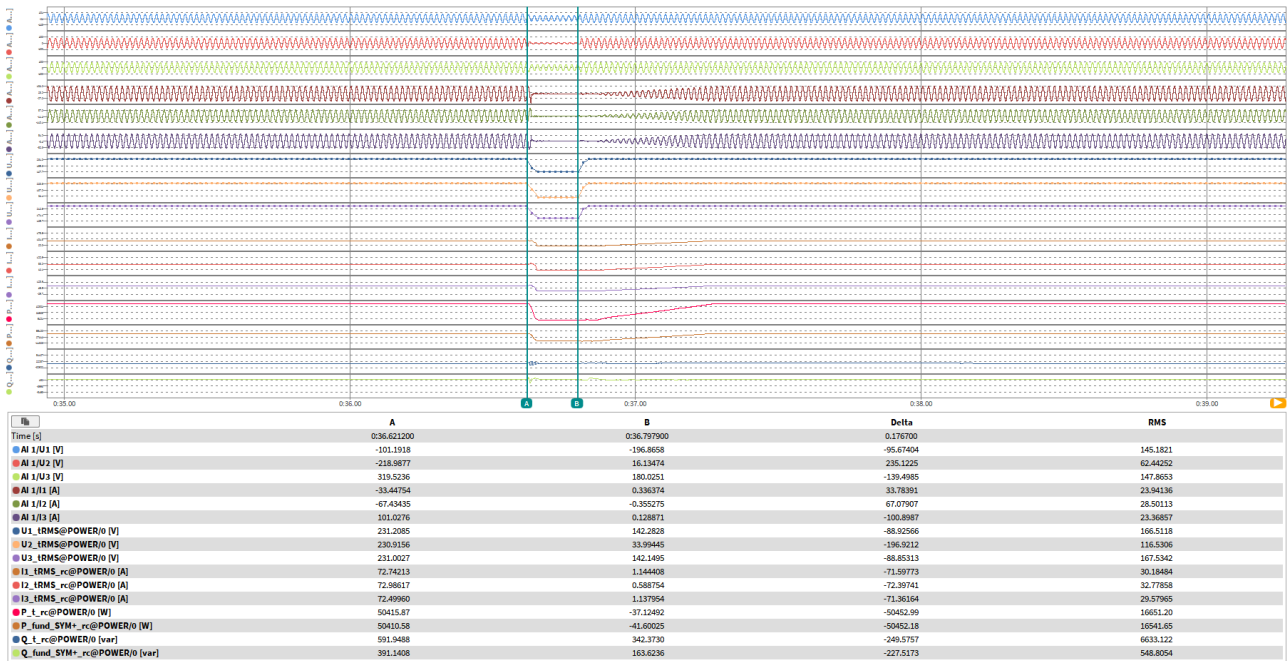

t1 to t2

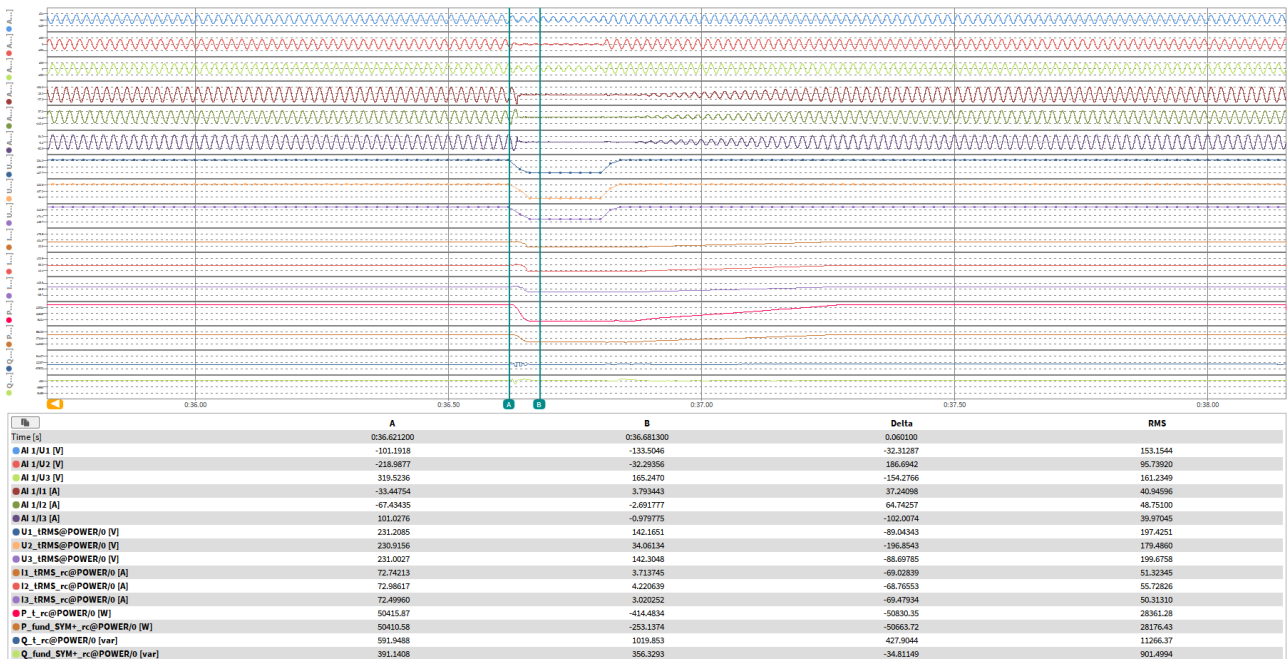

t1+60ms

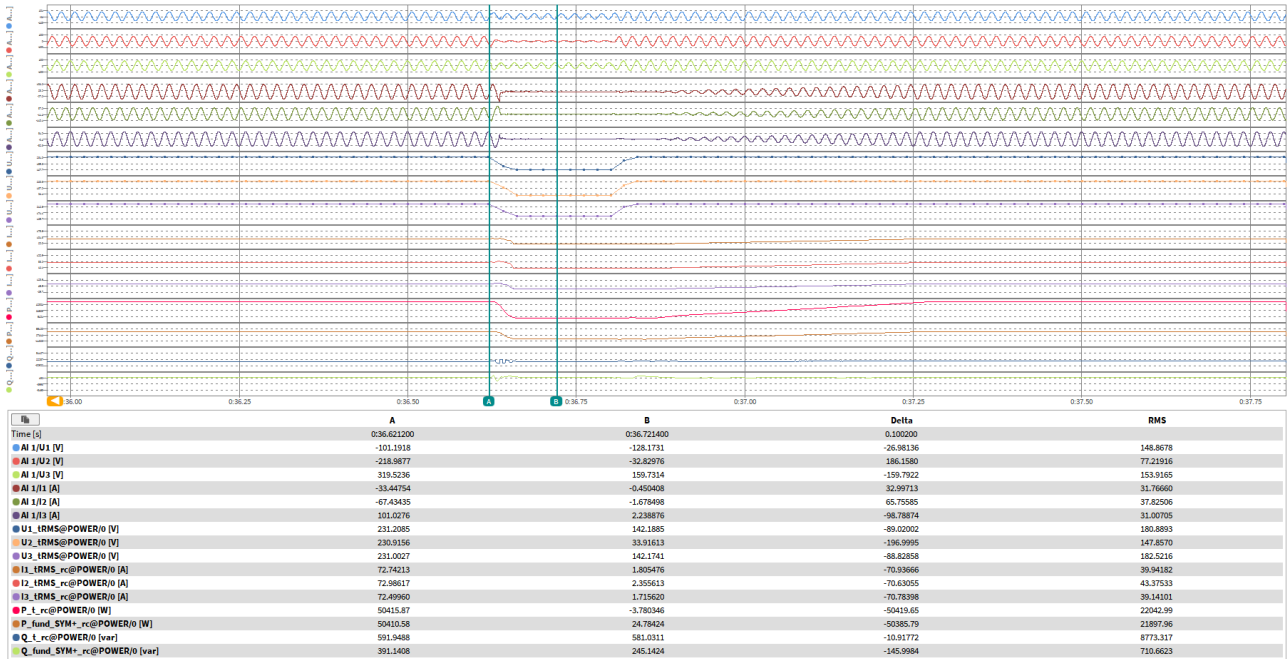

t1+100ms

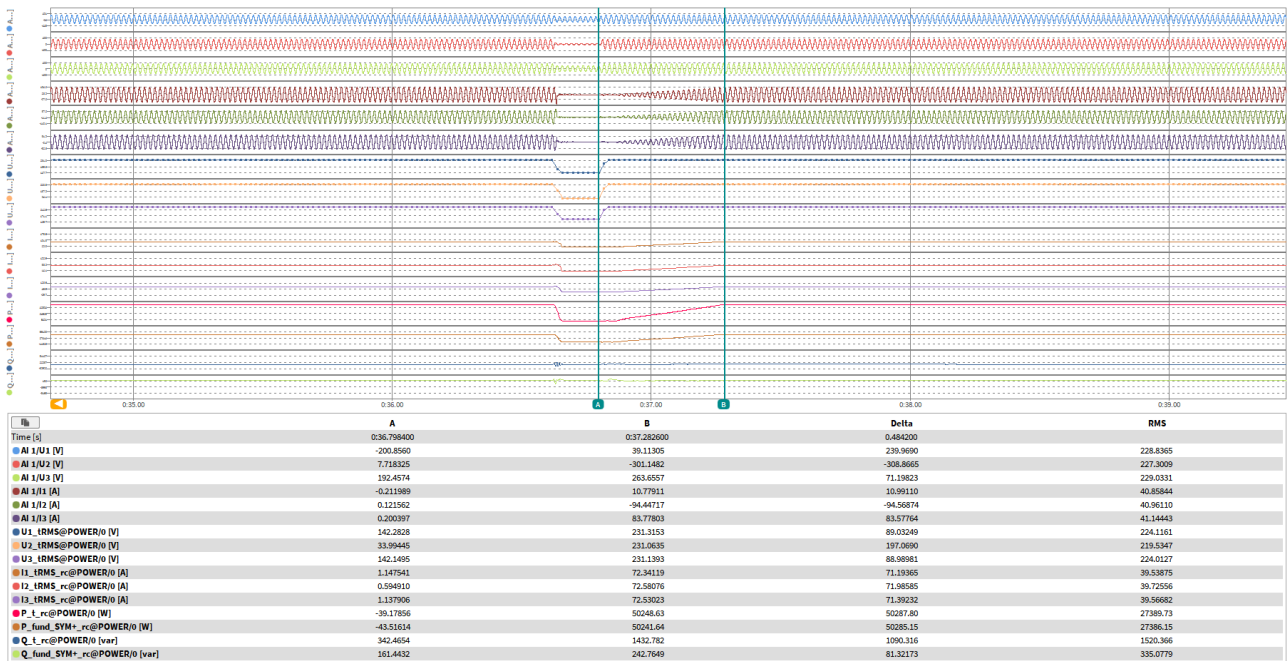

Active power rising time

Condition						Measurement
No.	Parameter	Phase ref.	Time ref.	unit		
General Info.	0	Test number	--	--	--	1.3(D2)
	1	Date	--	--	dd.mm.yyyy	14.06.2025
	2	Time (start of test)	--	--	hh:mm:ss.f	10:56:29
	3	Fault type (phase)	--	--		D2
	4	Setting voltage depth	Line to line	--	p.u.	0.15
	5	Setting dip duration		--		150
	6	Point of fault entry	Total	--	ms	19523
	7	Point of fault clearance	Total	--	ms	19686
	8	Fault duration in empty load test	Total	--	ms	181
	9	Voltage depth/height in empty load test	Total	t1+100ms to t2 and t1-10s to t1	p.u.	0.150
10	Pos.		p.u.		1.000	
Before dip <t1	11	Voltage	Line to neutral	t1-100s to t1	p.u.	1.003
	12	Current	Pos.	t1-500ms to t1-100ms	p.u.	1.009
	13	Active power	Total	t1-10s to t1	p.u.	1.009
	14		Pos.			1.009
	15	Reactive power	Total	t1-10s to t1	p.u.	0.010
	16		Pos.			0.009
17	Cosφ	--	t1-10s to t1	--	0.999	
During dip t1 to t2	18	Voltage	Line to neutral	t1+100ms to t2-20ms	p.u.	0.148
	19	Line current	Phase 1	t1+60ms	p.u.	0.030
	20		Phase 2			0.031
	21		Phase 3			0.016
	22	Line current	Phase 1	t1+100ms	p.u.	0.023
	23		Phase 2			0.026
	24		Phase 3			0.012
	25	Active power	Total	t1+100ms to t2-20ms	p.u.	0.003
26	Pos.		0.001			
After dip > t2	27	Voltage	Line to neutral	t2+3s to t2+10s	p.u.	1.003
	28	Active power	Total	t2+3s to t2+10s	p.u.	1.009
	29		Pos.			1.009
	39	Active power rising time	Pos.	--	s	0.626
	31	Reactive power	Total	t2+3s to t2+10s	p.u.	0.010
	32		Pos.			0.001
	33	Reactive power rising time	Pos.	--	s	--
	34	PGU does not disconnect from grid till 60s after fault	--	t2 to t2+60s	Yes / No	Yes

Test No. 1.3(D2) idle test

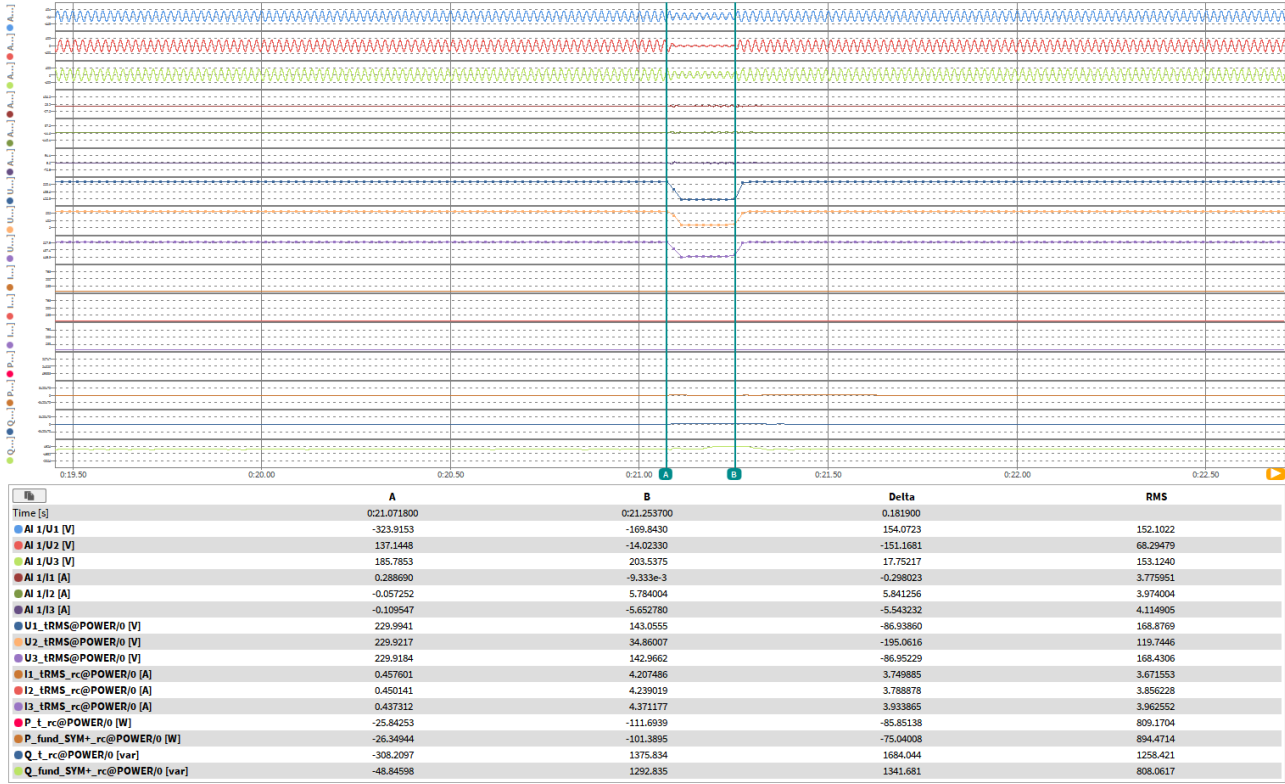

Test No. 1.3(D2) with PGU

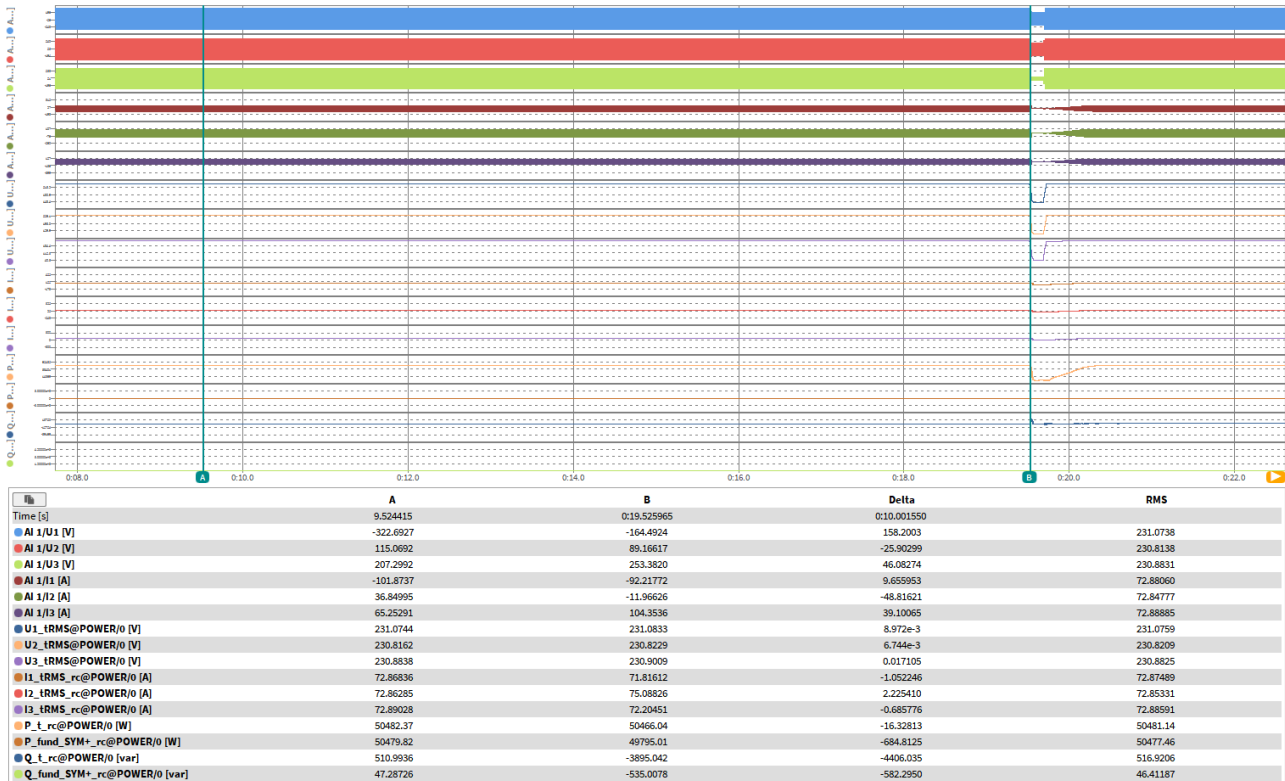

t1-10s to t1

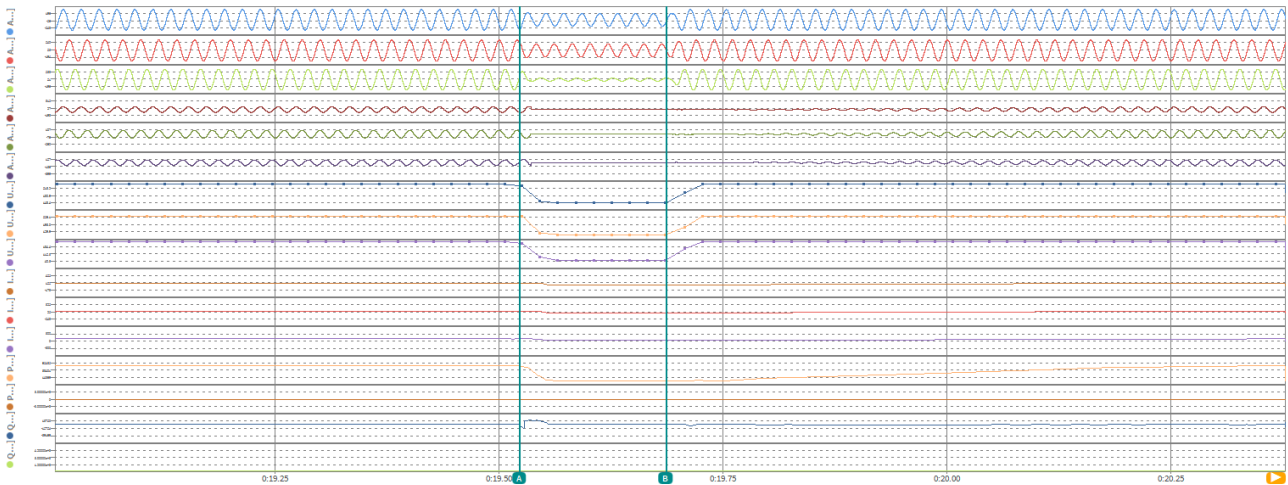

	A	B	Delta	RMS
Time [s]	0:19.523509	0:19.686903	0.163394	
AI 1/U1 [V]	-323.7179	-55.55106	268.1668	146.1454
AI 1/U2 [V]	200.1484	7.991553	-192.1568	143.5053
AI 1/U3 [V]	123.0228	47.04690	-75.97590	53.70772
AI 1/I1 [A]	-102.2790	0.157560	102.4365	23.53516
AI 1/I2 [A]	63.39786	1.134841	-62.26302	19.63351
AI 1/I3 [A]	38.96726	-1.170510	-40.13777	23.80256
U1_IRMS@POWER/0 [V]	231.0833	142.3976	-88.68579	166.0867
U2_IRMS@POWER/0 [V]	230.8229	142.3163	-88.50665	167.1375
U3_IRMS@POWER/0 [V]	230.9009	34.13491	-196.7660	111.1503
I1_IRMS_rc@POWER/0 [A]	70.40807	1.025292	-69.38277	29.84949
I2_IRMS_rc@POWER/0 [A]	73.58617	1.143493	-72.44267	28.25002
I3_IRMS_rc@POWER/0 [A]	74.51366	0.594397	-73.91927	29.70526
P_t_rc@POWER/0 [W]	50471.25	-47.11162	-50518.36	15776.62
P_fund_SYM+rc@POWER/0 [W]	49785.42	-47.71815	-49833.14	15535.26
Q_t_rc@POWER/0 [var]	529.9064	325.7466	-204.1597	5879.892
Q_fund_SYM+rc@POWER/0 [var]	62.33977	165.2250	102.8853	615.3587

t1 to t2

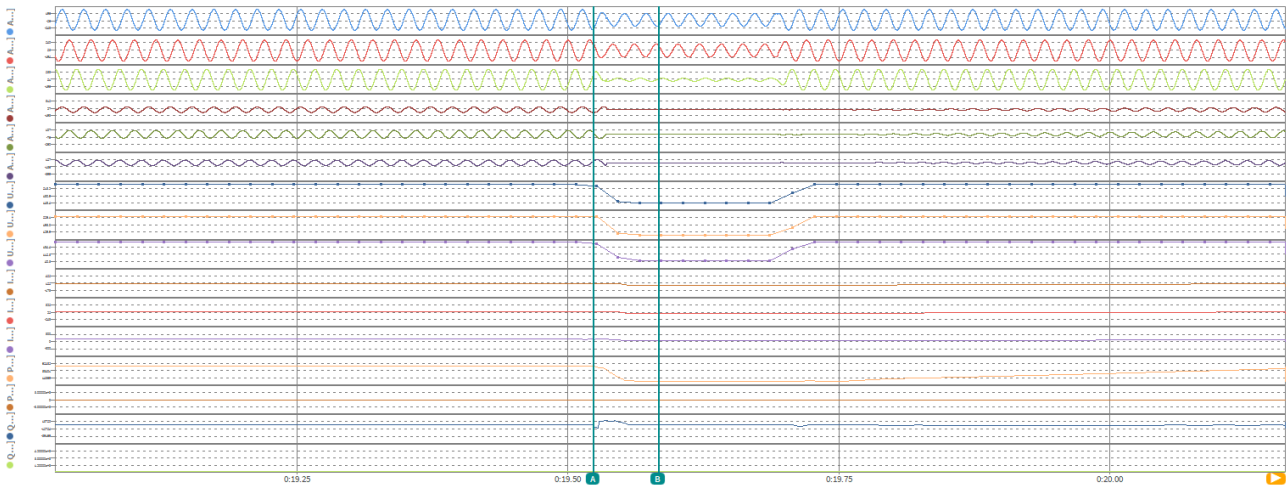

	A	B	Delta	RMS
Time [s]	0:19.523509	0:19.583515	0.060007	
AI 1/U1 [V]	-323.7179	-195.8344	127.8834	152.3907
AI 1/U2 [V]	200.1484	179.4620	-20.68639	147.0870
AI 1/U3 [V]	123.0228	16.18767	-106.8351	76.39198
AI 1/I1 [A]	-102.2790	0.801290	103.0803	38.75693
AI 1/I2 [A]	63.39786	0.181167	-63.21669	32.29025
AI 1/I3 [A]	38.96726	-0.872487	-39.83975	39.24460
U1_IRMS@POWER/0 [V]	231.0833	142.2366	-88.84674	151.6843
U2_IRMS@POWER/0 [V]	230.8229	142.0551	-88.76785	163.8588
U3_IRMS@POWER/0 [V]	230.9009	34.12763	-196.7732	162.3138
I1_IRMS_rc@POWER/0 [A]	70.40807	2.173976	-68.23409	48.88926
I2_IRMS_rc@POWER/0 [A]	73.58617	2.239465	-71.34770	46.25228
I3_IRMS_rc@POWER/0 [A]	74.51366	1.192926	-73.32074	48.69405
P_t_rc@POWER/0 [W]	50471.25	-411.3639	-50882.61	25885.56
P_fund_SYM+rc@POWER/0 [W]	49785.42	-278.2332	-50063.66	25471.64
Q_t_rc@POWER/0 [var]	529.9064	526.1273	-3.779053	9621.870
Q_fund_SYM+rc@POWER/0 [var]	62.33977	251.6466	189.3069	981.3961

t1+60ms

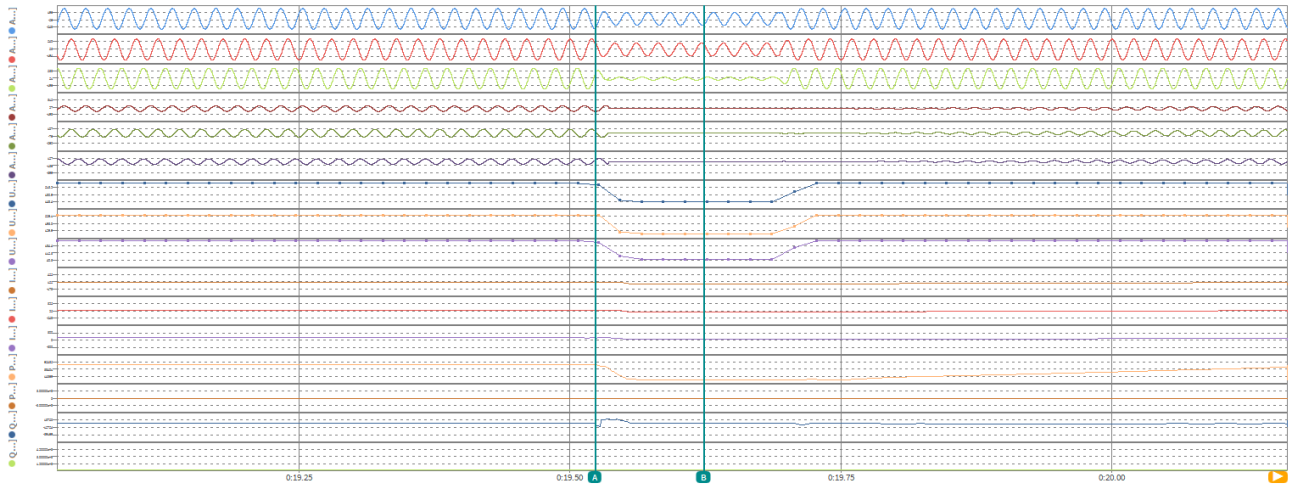

	A	B	Delta	RMS
Time [s]	0:19.523509	0:19.623783	0:100274	
AI 1/U1 [V]	-323.7179	-192.4374	131.2804	148.5529
AI 1/U2 [V]	200.1484	173.9041	-26.64423	145.1994
AI 1/U3 [V]	123.0228	18.93330	-104.0895	62.92730
AI 1/I1 [A]	-102.2790	-0.963008	101.3160	30.03689
AI 1/I2 [A]	63.39786	1.981227	-61.41663	25.04682
AI 1/I3 [A]	38.96726	-0.908250	-39.87551	30.38509
U1_IRMS@POWER/0 [V]	231.0833	142.3151	-88.76826	176.7587
U2_IRMS@POWER/0 [V]	230.8229	142.1179	-88.70503	178.2850
U3_IRMS@POWER/0 [V]	230.9009	34.04689	-196.8540	133.9783
I1_IRMS_rc@POWER/0 [A]	70.40807	1.674397	-68.73367	38.02509
I2_IRMS_rc@POWER/0 [A]	73.58617	1.943609	-71.64256	35.98058
I3_IRMS_rc@POWER/0 [A]	74.51366	0.902647	-73.61102	37.84778
P_t_rc@POWER/0 [W]	50471.25	-170.7663	-50642.01	20103.60
P_fund_SYM+rc@POWER/0 [W]	49785.42	-73.20787	-49858.63	19796.09
Q_t_rc@POWER/0 [var]	529.9064	518.0153	-11.89111	7486.259
Q_fund_SYM+rc@POWER/0 [var]	62.33977	199.5922	97.25241	773.7955

t1+100ms

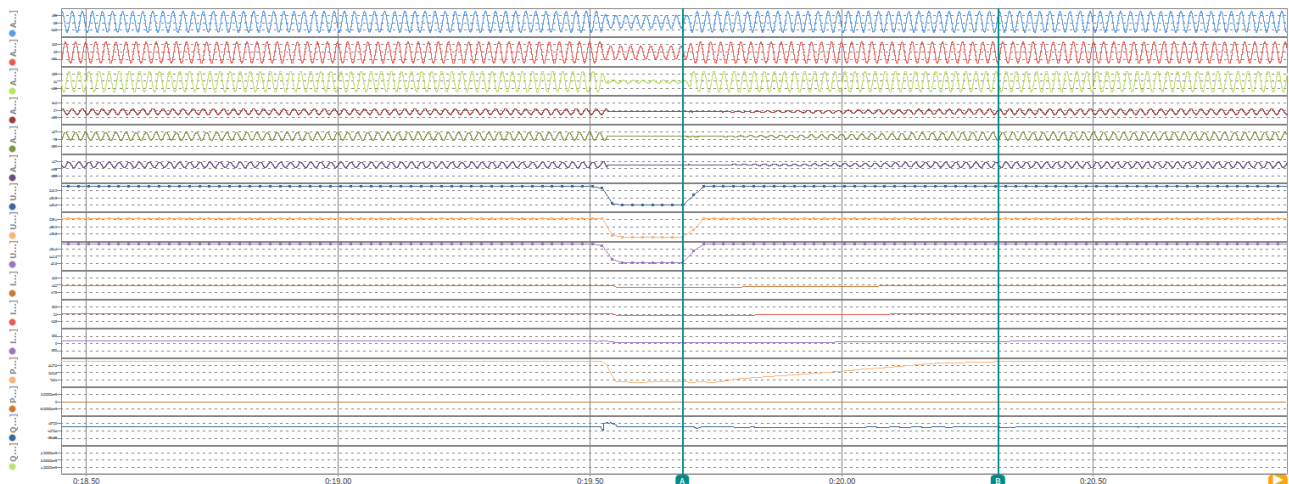

	A	B	Delta	RMS
Time [s]	0:19.685465	0:20.311675	0:626209	
AI 1/U1 [V]	-136.3285	243.1622	379.4906	228.6870
AI 1/U2 [V]	97.64195	-310.2055	-407.8474	228.9980
AI 1/U3 [V]	39.02436	65.93299	26.90864	227.8821
AI 1/I1 [A]	0.396978	78.27541	77.87943	45.12876
AI 1/I2 [A]	0.574557	-65.81808	-66.39264	45.36407
AI 1/I3 [A]	-0.848645	17.59303	18.44168	45.36183
U1_IRMS@POWER/0 [V]	142.3976	231.1266	88.72903	225.1196
U2_IRMS@POWER/0 [V]	142.3163	230.8985	88.58224	224.7527
U3_IRMS@POWER/0 [V]	34.13491	230.9646	196.8297	221.6715
I1_IRMS_rc@POWER/0 [A]	1.023262	71.40118	70.37791	44.31416
I2_IRMS_rc@POWER/0 [A]	1.150577	71.52605	70.37547	44.31340
I3_IRMS_rc@POWER/0 [A]	0.603003	71.66612	71.06312	44.34305
P_t_rc@POWER/0 [W]	-45.37043	49545.19	49590.56	30658.69
P_fund_SYM+rc@POWER/0 [W]	-47.46675	49537.58	49585.05	30654.27
Q_t_rc@POWER/0 [var]	327.0134	1571.445	1244.432	1461.846
Q_fund_SYM+rc@POWER/0 [var]	167.6742	5.390247	-162.2839	285.0142

Active power rising time

Condition						Measurement
	No.	Parameter	Phase ref.	Time ref.	unit	
General Info.	0	Test number	--	--	--	1.4
	1	Date	--	--	dd.mm.yyyy	13.06.2025
	2	Time (start of test)	--	--	hh:mm:ss.f	17:38:56
	3	Fault type (phase)	--	--		D1
	4	Setting voltage depth	Line to line	--		p.u.
	5	Setting dip duration		--		150
	6	Point of fault entry	Total	--		ms
	7	Point of fault clearance	Total	--		ms
	8	Fault duration in empty load test	Total	--		ms
	9	Voltage depth/height in empty load test	Total	t1+100ms to t2 and t1-10s to t1		p.u.
10	Pos.				p.u.	
Before dip <t1	11	Voltage	Line to neutral	t1-100s to t1		p.u.
	12	Current	Pos.	t1-500ms to t1-100ms		p.u.
	13	Active power	Total	t1-10s to t1		p.u.
	14		Pos.			p.u.
	15	Reactive power	Total	t1-10s to t1		p.u.
	16		Pos.			p.u.
17	Cosφ	--	t1-10s to t1		--	
During dip t1 to t2	18	Voltage	Line to neutral	t1+100ms to t2-20ms		p.u.
	19	Line current	Phase 1	t1+60ms		p.u.
	20		Phase 2			p.u.
	21		Phase 3			p.u.
	22	Line current	Phase 1	t1+100ms		p.u.
	23		Phase 2			p.u.
	24		Phase 3			p.u.
	25	Active power	Total	t1+100ms to t2-20ms		p.u.
26	Pos.				p.u.	
After dip > t2	27	Voltage	Line to neutral	t2+3s to t2+10s		p.u.
	28	Active power	Total	t2+3s to t2+10s		p.u.
	29		Pos.			p.u.
	39	Active power rising time	Pos.	--		s
	31	Reactive power	Total	t2+3s to t2+10s		p.u.
	32		Pos.			p.u.
	33	Reactive power rising time	Pos.	--		s
	34	PGU does not disconnect from grid till 60s after fault	--	t2 to t2+60s		Yes / No

Test No. 1.4 idle test

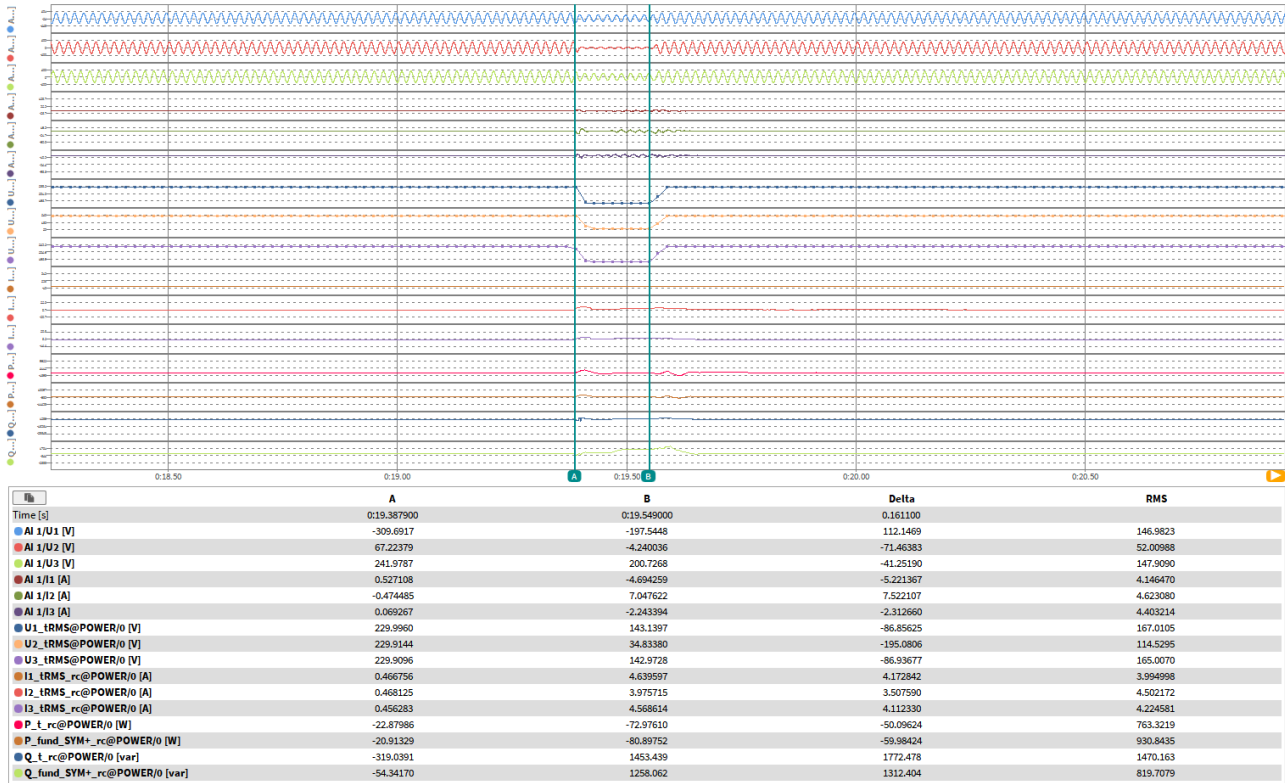

Test No. 1.4 with PGU

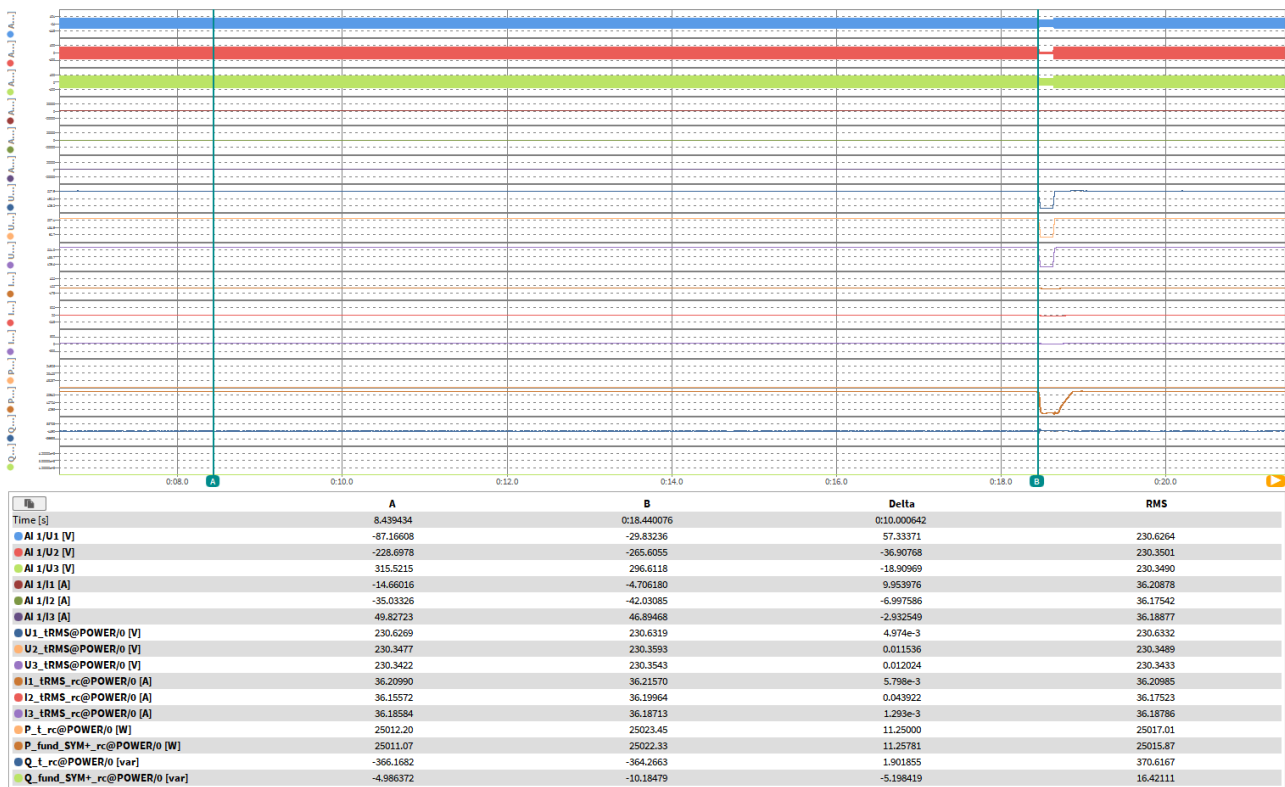

t1-10s to t1

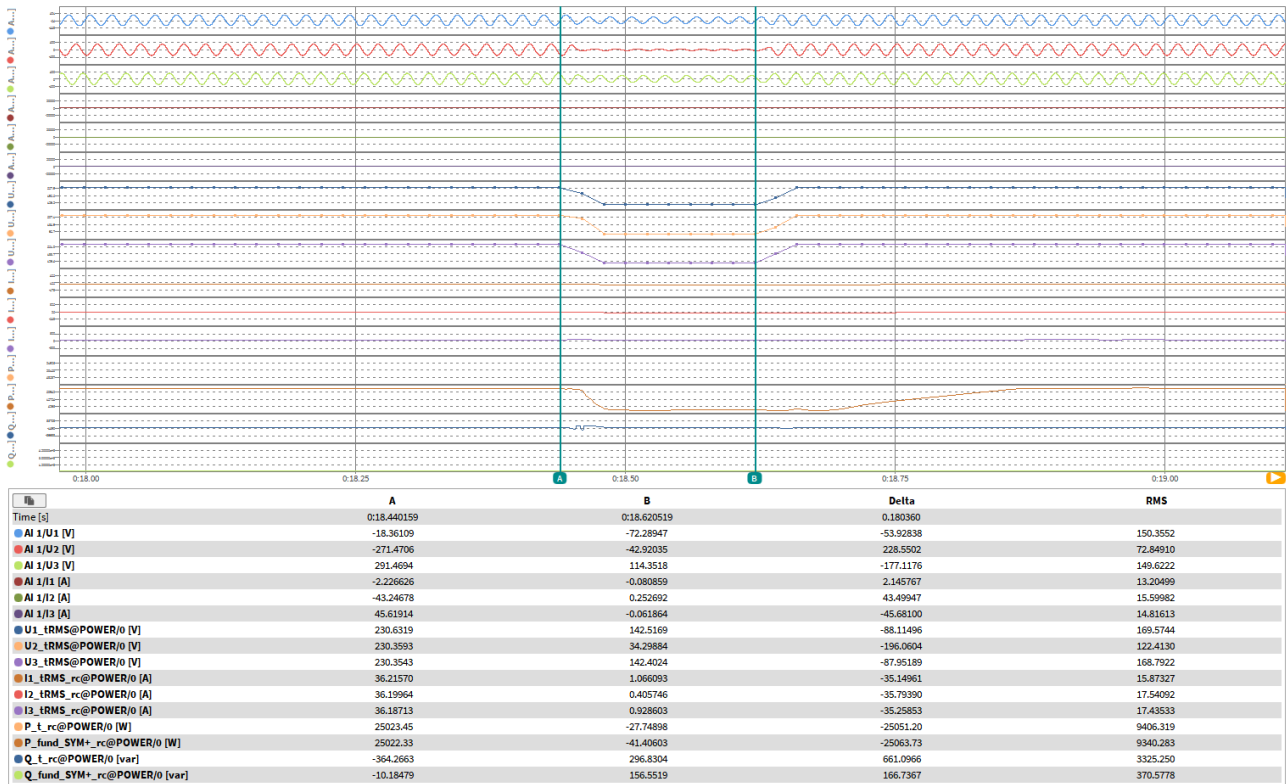

t1 to t2

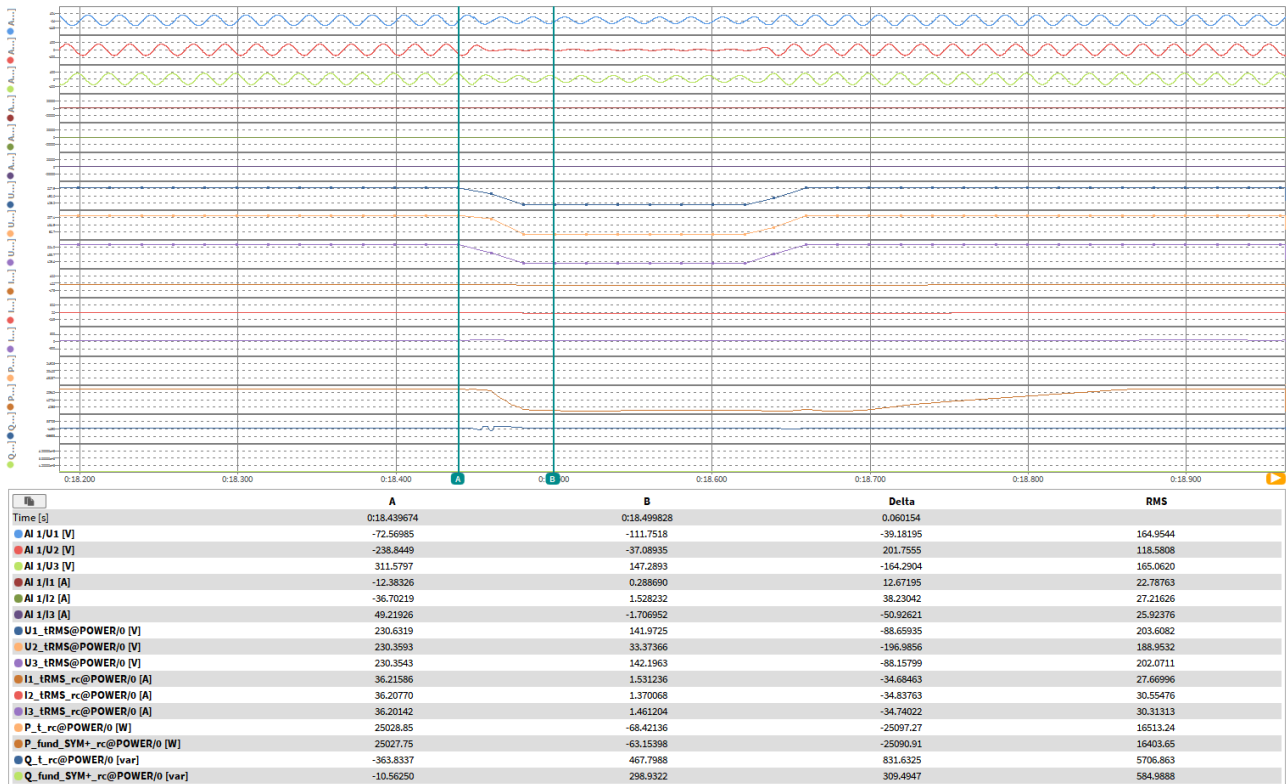

t1+60ms

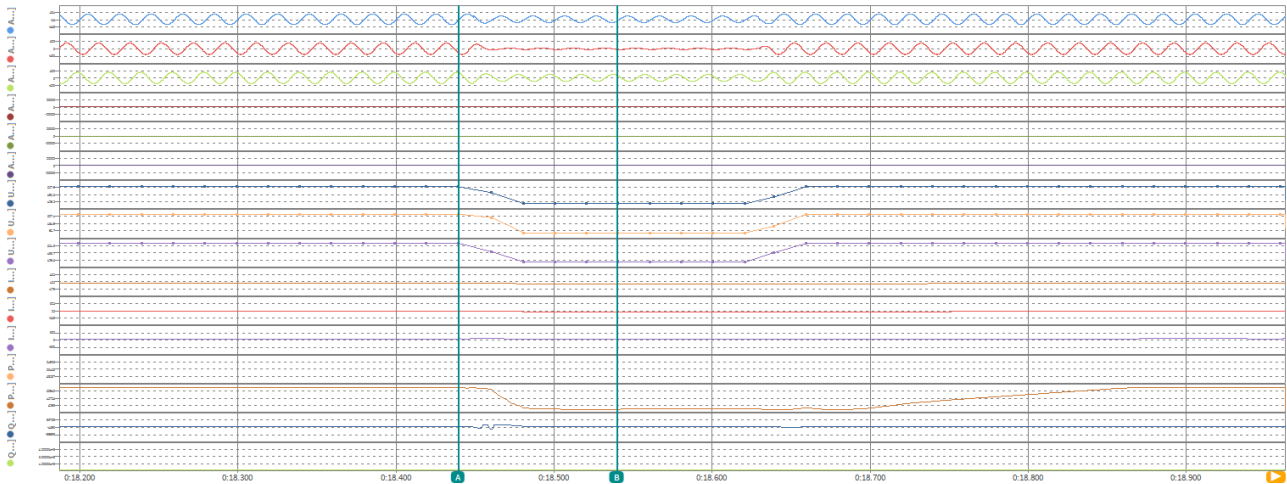

	A	B	Delta	RMS
Time [s]	0:18.439674	0:18.540063	0:100389	
AI 1/U1 [V]	-72.56985	-100.7767	-28.20683	156.2608
AI 1/U2 [V]	-238.8449	-390.02483	199.8201	94.36887
AI 1/U3 [V]	311.5797	139.1349	-172.4448	156.3728
AI 1/I1 [A]	-12.38326	0.622476	13.00573	17.68414
AI 1/I2 [A]	-36.70219	0.658004	37.36019	21.08612
AI 1/I3 [A]	49.21926	-1.170510	-50.38977	20.12469
U1_IRMS@POWER/0 [V]	230.6319	142.3775	-88.25439	185.4572
U2_IRMS@POWER/0 [V]	230.3993	34.19107	-196.1682	155.5402
U3_IRMS@POWER/0 [V]	230.3543	142.3342	-88.02011	184.3120
I1_IRMS@POWER/0 [A]	36.21586	1.310367	-34.90550	21.42599
I2_IRMS@POWER/0 [A]	36.20770	0.650448	-35.55725	23.63556
I3_IRMS@POWER/0 [A]	36.20142	1.681036	-34.52038	23.47954
P_t_rc@POWER/0 [W]	25028.85	-282.3792	-25311.23	12772.66
P_fund_SYM+rc@POWER/0 [W]	25027.75	-171.0933	-25198.85	12686.50
Q_t_rc@POWER/0 [var]	-363.8337	348.0563	711.8900	4420.974
Q_fund_SYM+rc@POWER/0 [var]	-10.56250	173.8841	184.4466	473.9735

t1+100ms

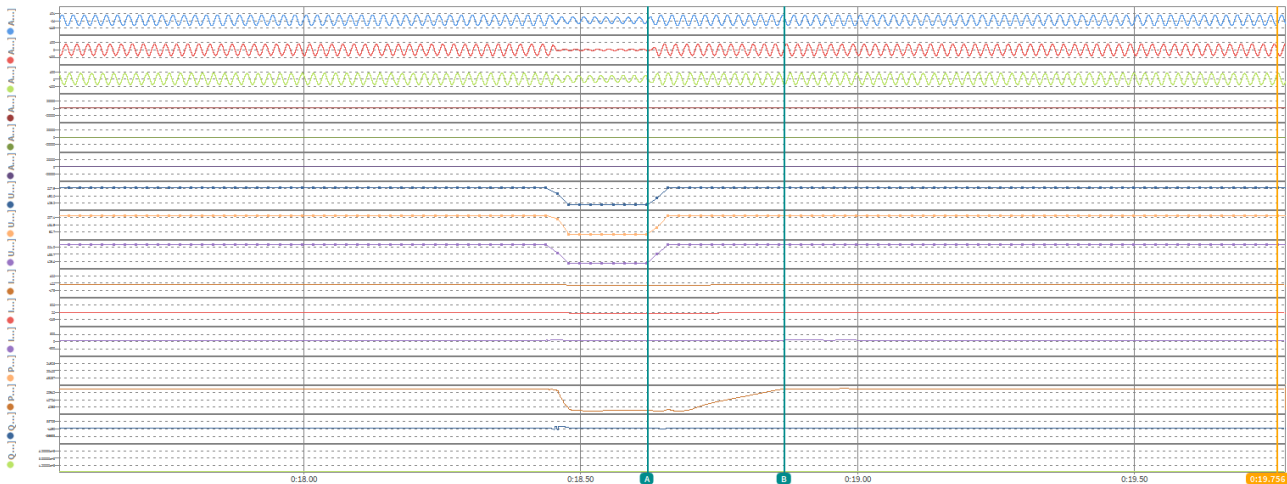

	A	B	Delta	RMS
Time [s]	0:18.620669	0:18.868078	0:247410	
AI 1/U1 [V]	-66.40554	216.7232	283.1288	226.9750
AI 1/U2 [V]	-43.65134	104.0015	147.6529	222.8808
AI 1/U3 [V]	109.5150	-319.2020	-428.7169	225.7415
AI 1/I1 [A]	-0.021254	35.97995	36.00121	20.70046
AI 1/I2 [A]	0.252692	13.48492	13.23223	20.30849
AI 1/I3 [A]	-0.109547	-49.34299	-49.23344	20.37038
U1_IRMS@POWER/0 [V]	142.5169	230.7324	88.21550	216.3776
U2_IRMS@POWER/0 [V]	34.29884	230.5104	196.2116	206.5401
U3_IRMS@POWER/0 [V]	142.4024	230.4552	88.05280	216.7418
I1_IRMS@POWER/0 [A]	1.066093	36.33090	35.26481	19.13581
I2_IRMS@POWER/0 [A]	0.405746	36.08360	35.67786	19.09783
I3_IRMS@POWER/0 [A]	0.928603	36.08373	35.15513	19.08821
P_t_rc@POWER/0 [W]	-27.74898	24982.79	25010.53	13110.91
P_fund_SYM+rc@POWER/0 [W]	-41.40603	24980.21	25021.62	13109.79
Q_t_rc@POWER/0 [var]	296.8304	1259.137	962.3062	1482.543
Q_fund_SYM+rc@POWER/0 [var]	156.5519	10.36703	-146.1849	506.7478

Active power rising time

Condition						Measurement
No.	Parameter	Phase ref.	Time ref.	unit		
General Info.	0	Test number	--	--	--	2.1
	1	Date	--	--	dd.mm.yyyy	14.06.2025
	2	Time (start of test)	--	--	hh:mm:ss.f	10:17:25
	3	Fault type (phase)	--	--		A
	4	Setting voltage depth	Line to line	--	p.u.	0.50
	5	Setting dip duration		--		1500
	6	Point of fault entry	Total	--	ms	16992
	7	Point of fault clearance	Total	--	ms	18497
	8	Fault duration in empty load test	Total	--	ms	1602
	9	Voltage depth/height in empty load test	Total	t1+100ms to t2 and t1-10s to t1	p.u.	0.500
10	Pos.		p.u.		1.000	
Before dip <t1	11	Voltage	Line to neutral	t1-100s to t1	p.u.	1.004
	12	Current	Pos.	t1-500ms to t1-100ms	p.u.	1.097
	13	Active power	Total	t1-10s to t1	p.u.	0.985
	14		Pos.			0.985
	15	Reactive power	Total	t1-10s to t1	p.u.	0.487
	16		Pos.			0.487
17	Cos ϕ	--	t1-10s to t1	--	0.896	
During dip t1 to t2	18	Voltage	Line to neutral	t1+100ms to t2-20ms	p.u.	0.498
	19	Line current	Phase 1	t1+60ms	p.u.	0.036
	20		Phase 2			0.026
	21		Phase 3			0.025
	22	Line current	Phase 1	t1+100ms	p.u.	0.013
	23		Phase 2			0.009
	24		Phase 3			0.012
	25	Active power	Total	t1+100ms to t2-20ms	p.u.	0.002
26	Pos.		0.002			
After dip > t2	27	Voltage	Line to neutral	t2+3s to t2+10s	p.u.	1.003
	28	Active power	Total	t2+3s to t2+10s	p.u.	0.985
	29		Pos.			0.985
	39	Active power rising time	Pos.	--	s	0.393
	31	Reactive power	Total	t2+3s to t2+10s	p.u.	0.483
	32		Pos.			0.481
	33	Reactive power rising time	Pos.	--	s	9.086
	34	PGU does not disconnect from grid till 60s after fault	--	t2 to t2+60s	Yes / No	Yes

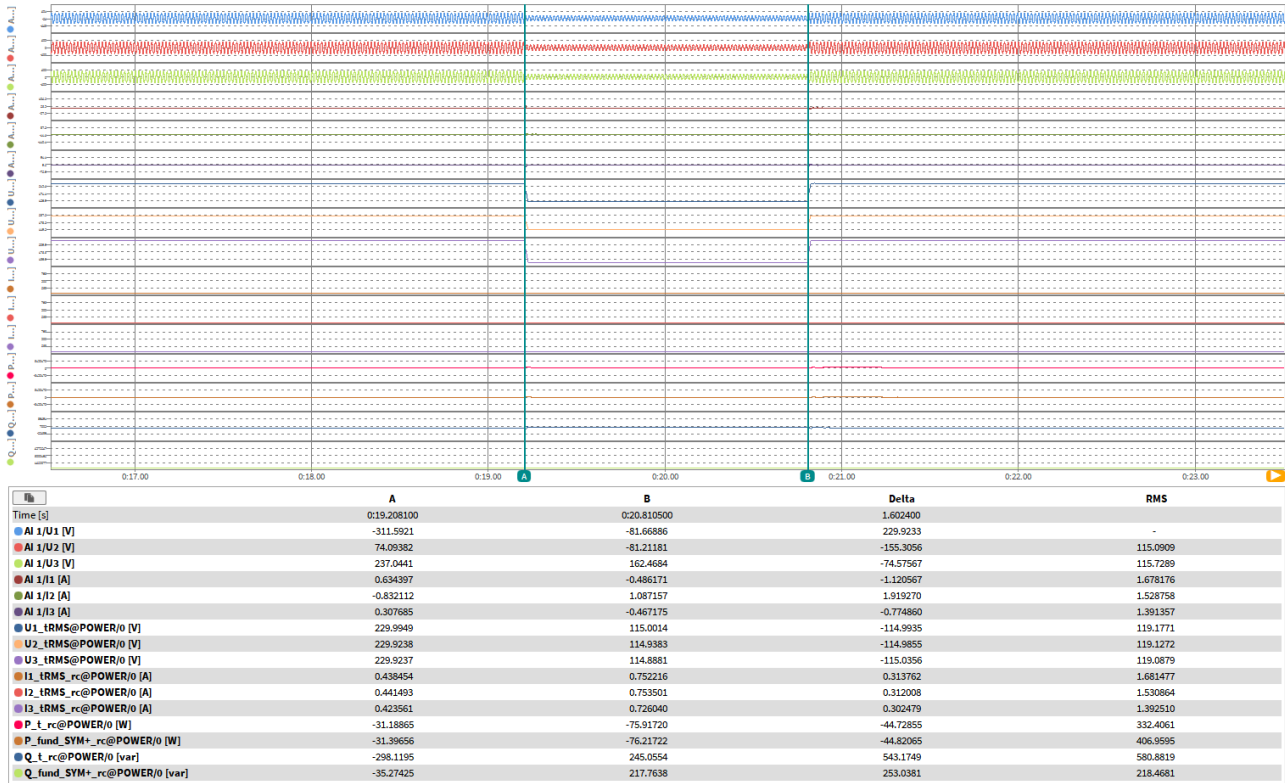
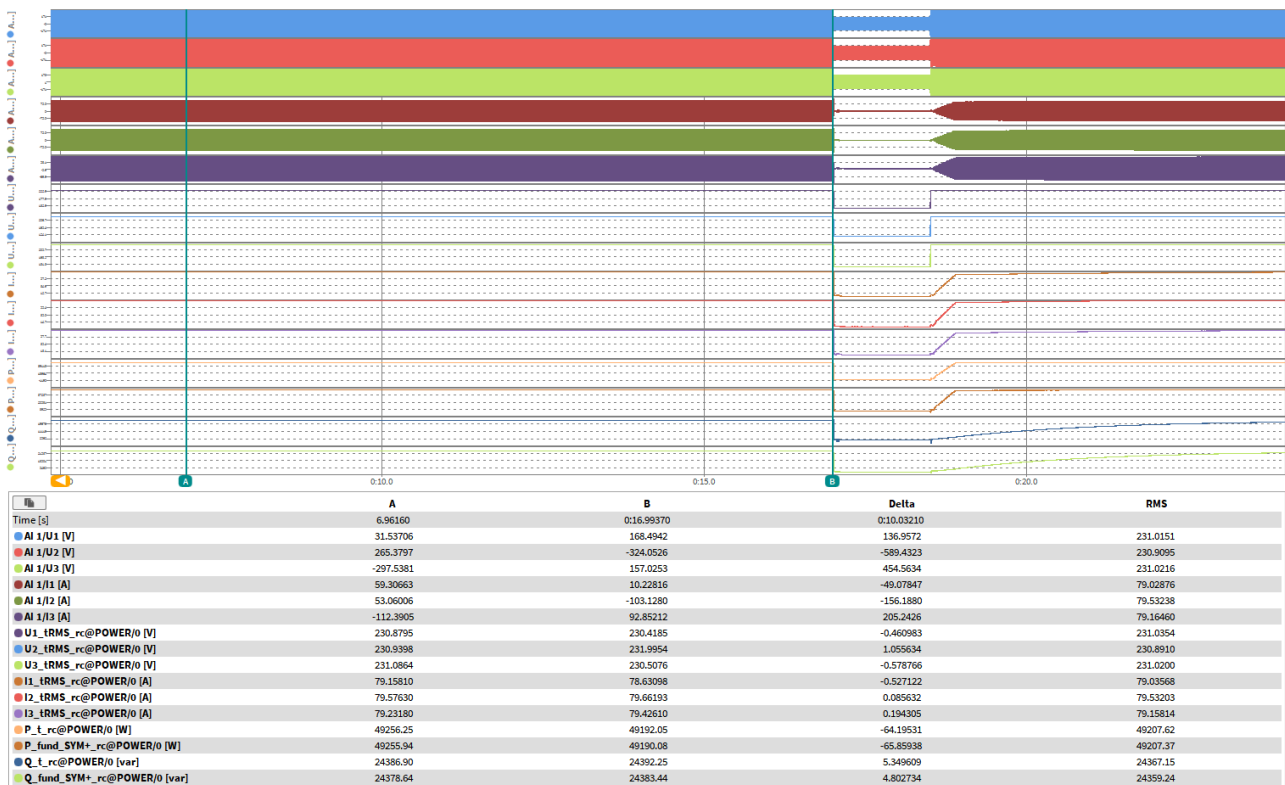
Test No. 2.1 idle test

Test No. 2.1 with PGU

t1-10s to t1

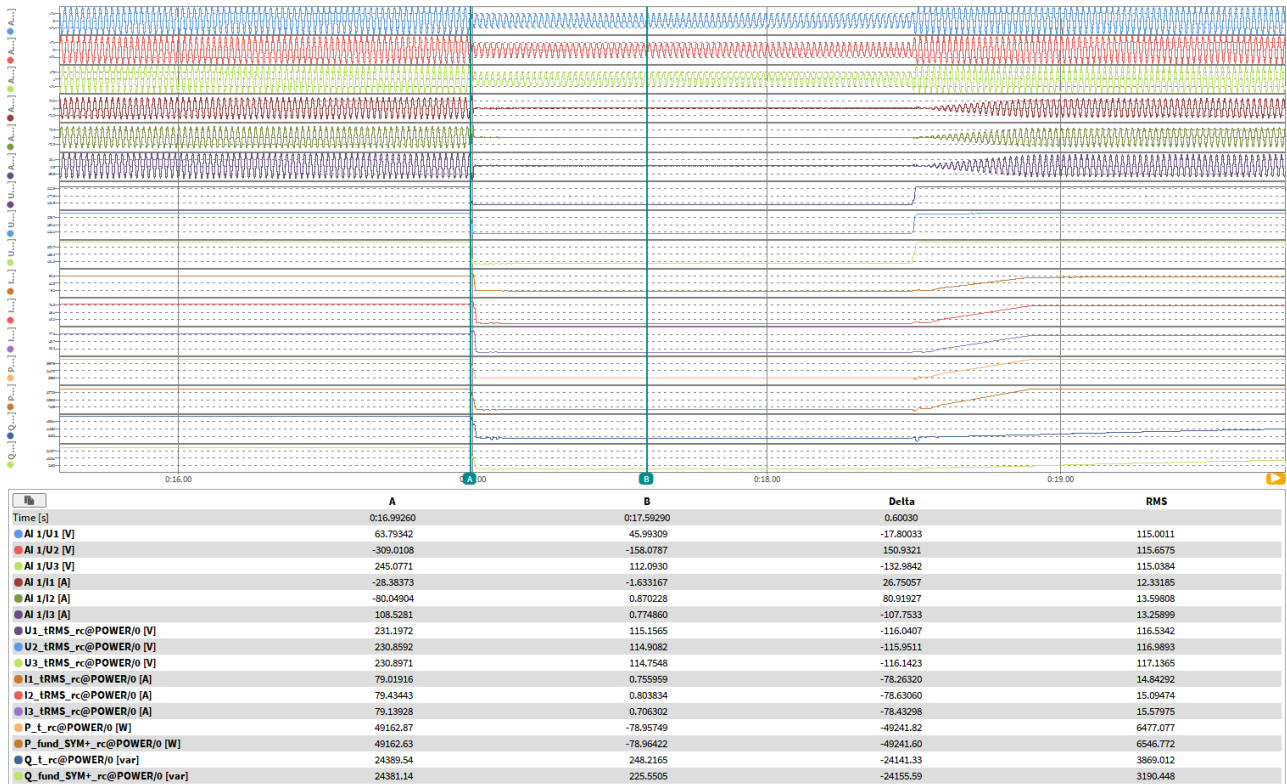

t1 to t2



t1+60ms

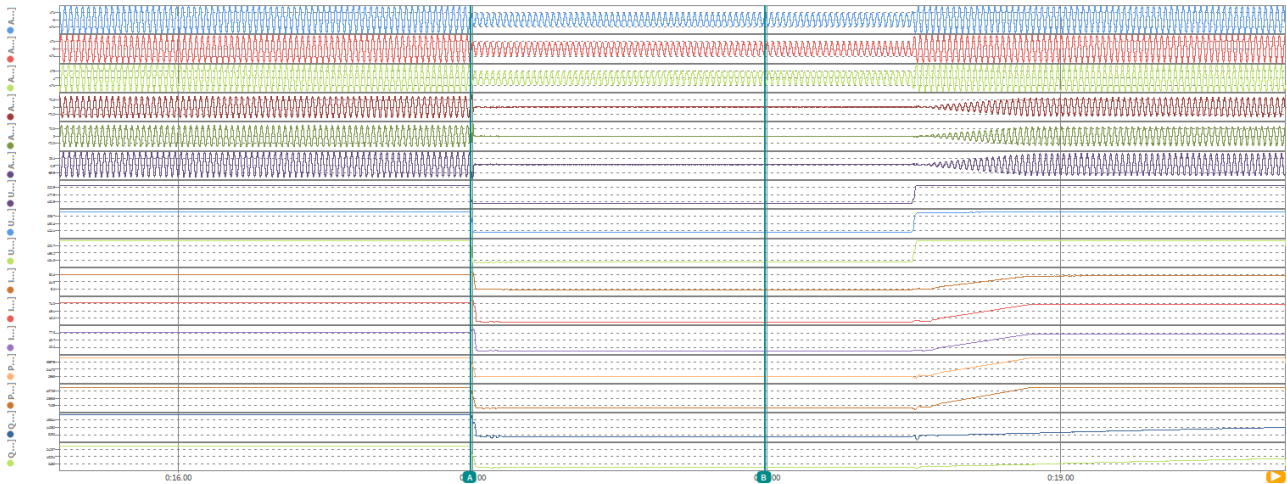

	A	B	Delta	RMS
Time [s]	0:16.99260	0:17.99350	1.00090	
AI 1/U1 [V]	63.79342	74.26835	10.47492	114.9749
AI 1/U2 [V]	-309.0108	-162.5331	146.4777	115.4013
AI 1/U3 [V]	245.0771	87.51107	-157.5661	114.9664
AI 1/I1 [A]	-28.38973	-1.001358	27.38238	9.569499
AI 1/I2 [A]	-80.04904	0.488758	80.53780	10.54250
AI 1/I3 [A]	108.5281	0.524521	-108.0036	10.28035
U1_IRMS_rc@POWER/0 [V]	231.1972	115.1419	-116.0553	115.9211
U2_IRMS_rc@POWER/0 [V]	230.8992	114.9348	-115.9244	116.1708
U3_IRMS_rc@POWER/0 [V]	230.8971	114.7122	-116.1849	116.2391
I1_IRMS_rc@POWER/0 [A]	79.01916	0.774170	-78.24499	11.50605
I2_IRMS_rc@POWER/0 [A]	79.43443	0.790993	-78.64344	11.70051
I3_IRMS_rc@POWER/0 [A]	79.13928	0.727215	-78.41207	12.07597
P_t_rc@POWER/0 [W]	49162.87	-82.06545	-49244.93	5016.673
P_fund_SYM+rc@POWER/0 [W]	49162.63	-82.06659	-49244.70	5070.646
Q_t_rc@POWER/0 [var]	24389.54	250.3656	-24139.18	3000.549
Q_fund_SYM+rc@POWER/0 [var]	24381.14	227.4241	-24153.72	2475.002

t1+100ms

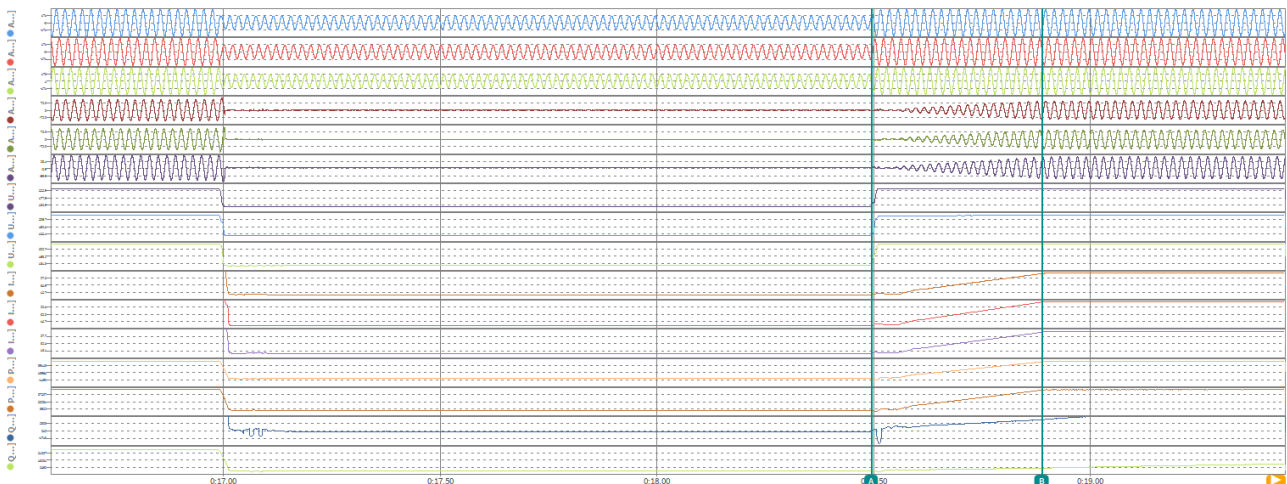

	A	B	Delta	RMS
Time [s]	0:18.49630	0:18.88820	0.39290	
AI 1/U1 [V]	147.8946	-302.4793	-450.3739	229.8659
AI 1/U2 [V]	-149.4677	44.16013	193.6278	229.3976
AI 1/U3 [V]	1.142740	256.8944	255.7516	228.8819
AI 1/I1 [A]	-1.919270	-91.85076	-89.93149	40.15820
AI 1/I2 [A]	1.049042	16.79659	15.74755	40.27155
AI 1/I3 [A]	0.882149	75.07802	74.19587	39.77543
U1_IRMS_rc@POWER/0 [V]	115.1170	231.0152	115.8982	228.0054
U2_IRMS_rc@POWER/0 [V]	114.9470	230.9419	115.9949	227.9637
U3_IRMS_rc@POWER/0 [V]	114.6858	231.1406	116.4549	227.9166
I1_IRMS_rc@POWER/0 [A]	0.760229	69.04226	68.28203	39.12235
I2_IRMS_rc@POWER/0 [A]	0.781651	69.63456	68.85291	39.26406
I3_IRMS_rc@POWER/0 [A]	0.734303	68.73009	67.99578	39.13906
P_t_rc@POWER/0 [W]	-85.61304	47744.27	47829.89	26978.86
P_fund_SYM+rc@POWER/0 [W]	-85.62012	47742.88	47828.50	26977.84
Q_t_rc@POWER/0 [var]	247.1708	3989.965	3742.795	2730.612
Q_fund_SYM+rc@POWER/0 [var]	223.3164	3540.721	3317.405	2306.166

Active power rising time

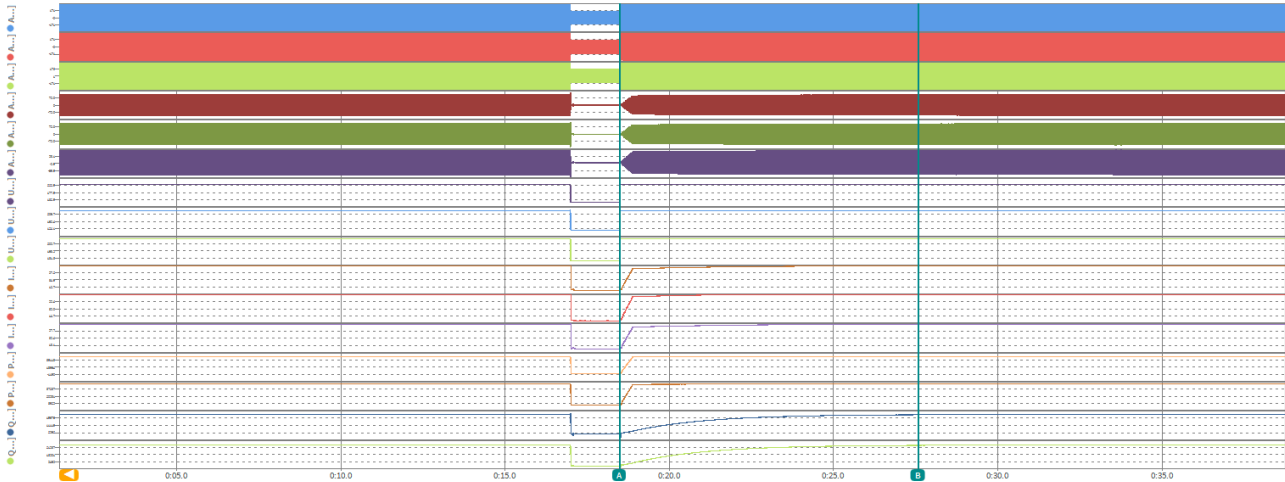

	A	B	Delta	RMS
Time [s]	0:18.49530	0:27.58220	9.08690	
AI 1/U1 [V]	147.8946	-16.67738	-164.5720	230.9573
AI 1/U2 [V]	-149.4677	290.5562	440.0239	230.8066
AI 1/U3 [V]	1.142740	-274.6694	-275.8122	230.9656
AI 1/I1 [A]	-1.919270	40.35235	42.27162	75.15356
AI 1/I2 [A]	1.049042	66.47110	65.42206	75.58548
AI 1/I3 [A]	0.882149	-106.8354	-107.7175	75.26126
U1_TRMS_rc@POWER/0 [V]	115.1170	230.8689	115.7519	230.8945
U2_TRMS_rc@POWER/0 [V]	114.9470	230.9448	115.9977	230.7658
U3_TRMS_rc@POWER/0 [V]	114.6858	231.0894	116.4037	230.8858
I1_TRMS_rc@POWER/0 [A]	0.760229	78.89635	78.13612	75.11965
I2_TRMS_rc@POWER/0 [A]	0.781651	79.39103	78.60938	75.56394
I3_TRMS_rc@POWER/0 [A]	0.734303	79.07236	78.33805	75.23087
P_t_rc@POWER/0 [W]	-85.61304	49269.59	49355.21	48375.36
P_fund_SYM+_rc@POWER/0 [W]	-85.62012	49270.02	49355.64	48375.32
Q_t_rc@POWER/0 [var]	247.1708	24041.78	23794.60	19561.40
Q_fund_SYM+_rc@POWER/0 [var]	223.3164	23940.38	23717.06	19449.87

Reactive power rising time

Condition						Measurement
No.	Parameter	Phase ref.	Time ref.	unit		
General Info.	0	Test number	--	--	--	2.2
	1	Date	--	--	dd.mm.yyyy	08.06.2025
	2	Time (start of test)	--	--	hh:mm:ss.f	16:38:46
	3	Fault type (phase)	--	--		A
	4	Setting voltage depth	Line to line	--	p.u.	0.50
	5	Setting dip duration		--		1500
	6	Point of fault entry	Total	--	ms	16646
	7	Point of fault clearance	Total	--	ms	18152
	8	Fault duration in empty load test	Total	--	ms	1602
	9	Voltage depth/height in empty load test	Total	t1+100ms to t2 and t1-10s to t1	p.u.	0.500
10	Pos.		p.u.		1.000	
Before dip <t1	11	Voltage	Line to neutral	t1-100s to t1	p.u.	1.002
	12	Current	Pos.	t1-500ms to t1-100ms	p.u.	0.555
	13	Active power	Total	t1-10s to t1	p.u.	0.497
	14		Pos.			0.497
	15	Reactive power	Total	t1-10s to t1	p.u.	0.244
	16		Pos.			0.244
17	Cos ϕ	--	t1-10s to t1	--	0.897	
During dip t1 to t2	18	Voltage	Line to neutral	t1+100ms to t2-20ms	p.u.	0.498
	19	Line current	Phase 1	t1+60ms	p.u.	0.017
	20		Phase 2			0.024
	21		Phase 3			0.022
	22	Line current	Phase 1	t1+100ms	p.u.	0.021
	23		Phase 2			0.013
	24		Phase 3			0.020
	25	Active power	Total	t1+100ms to t2-20ms	p.u.	0.001
26	Pos.		0.001			
After dip > t2	27	Voltage	Line to neutral	t2+3s to t2+10s	p.u.	1.002
	28	Active power	Total	t2+3s to t2+10s	p.u.	0.497
	29		Pos.			0.497
	39	Active power rising time	Pos.	--	s	0.218
	31	Reactive power	Total	t2+3s to t2+10s	p.u.	0.246
	32		Pos.			0.246
	33	Reactive power rising time	Pos.	--	s	9.976
	34	PGU does not disconnect from grid till 60s after fault	--	t2 to t2+60s	Yes / No	Yes

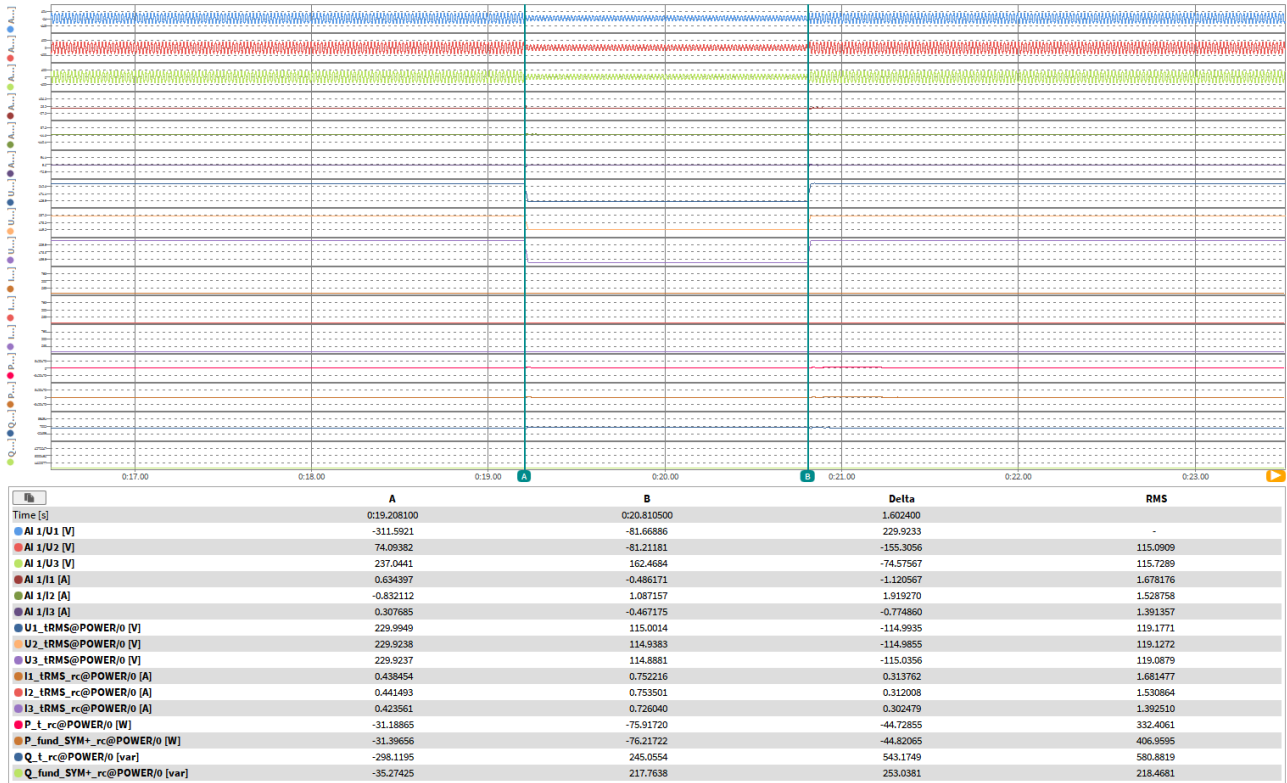
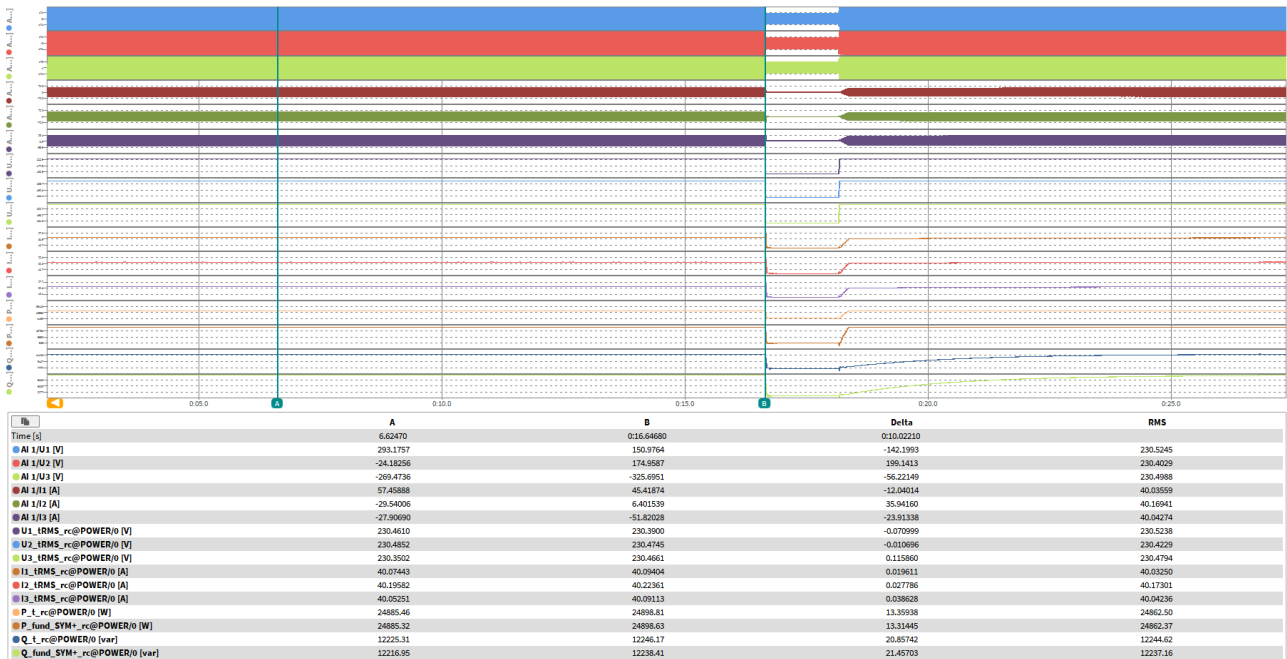
Test No. 2.2 idle test

Test No. 2.2 with PGU

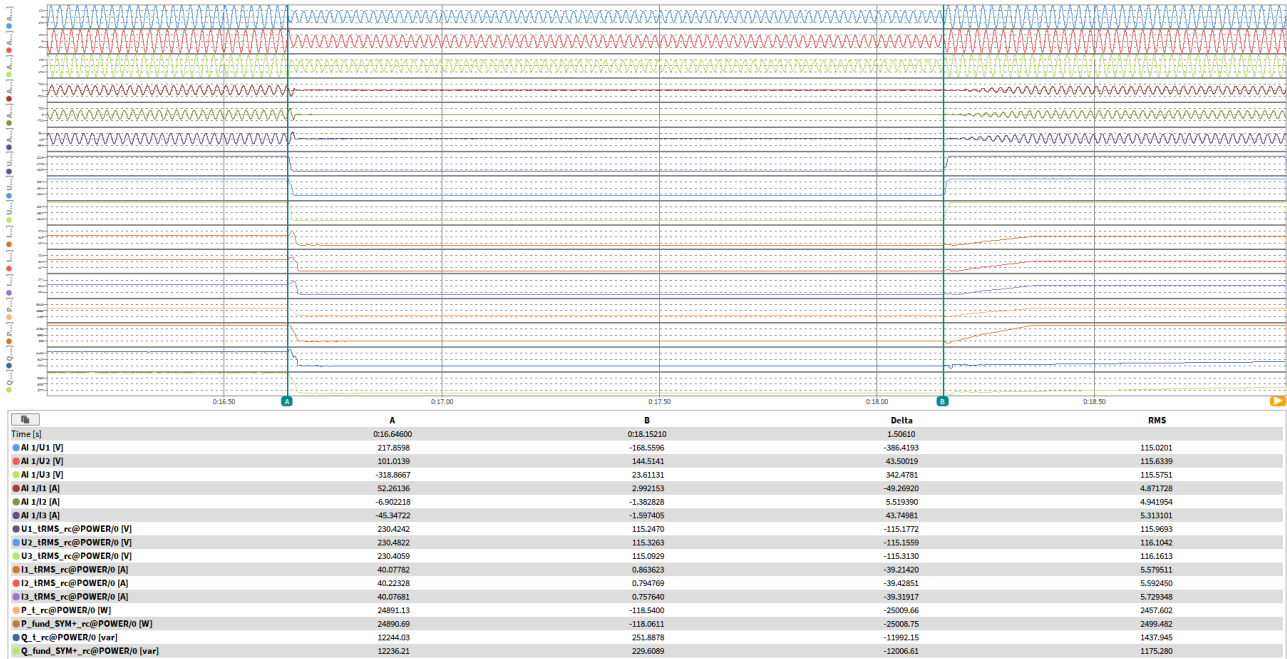
t1-10s to t1

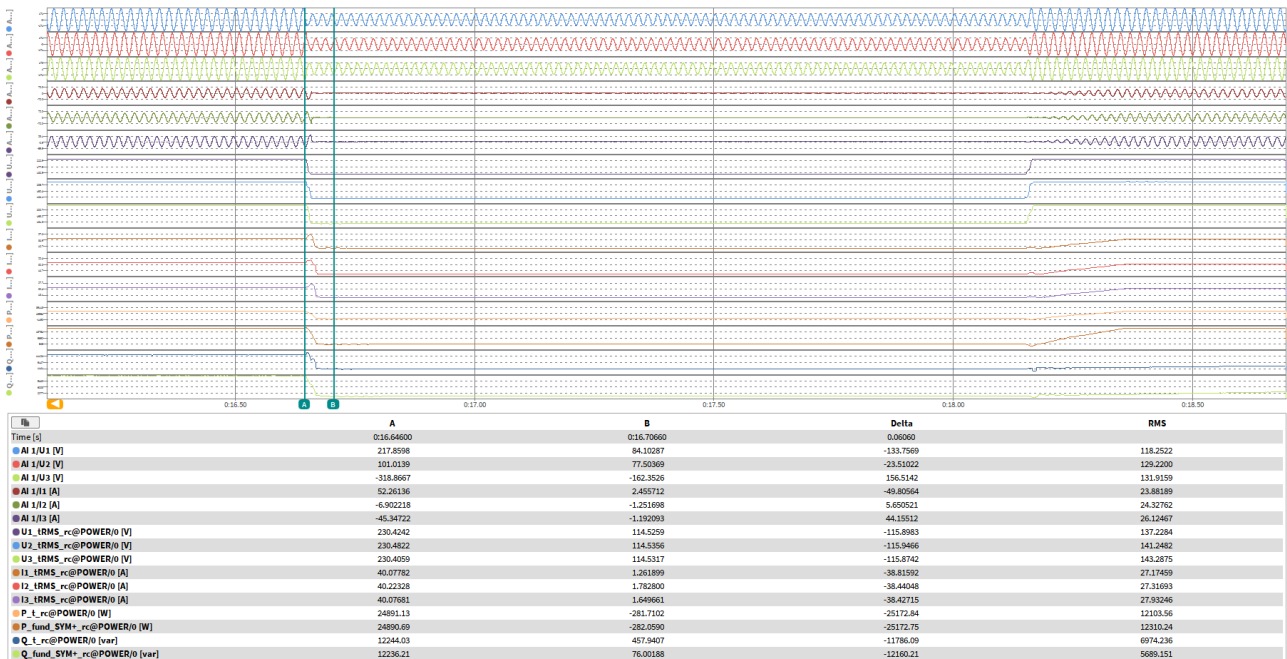

t1 to t2



t1+60ms

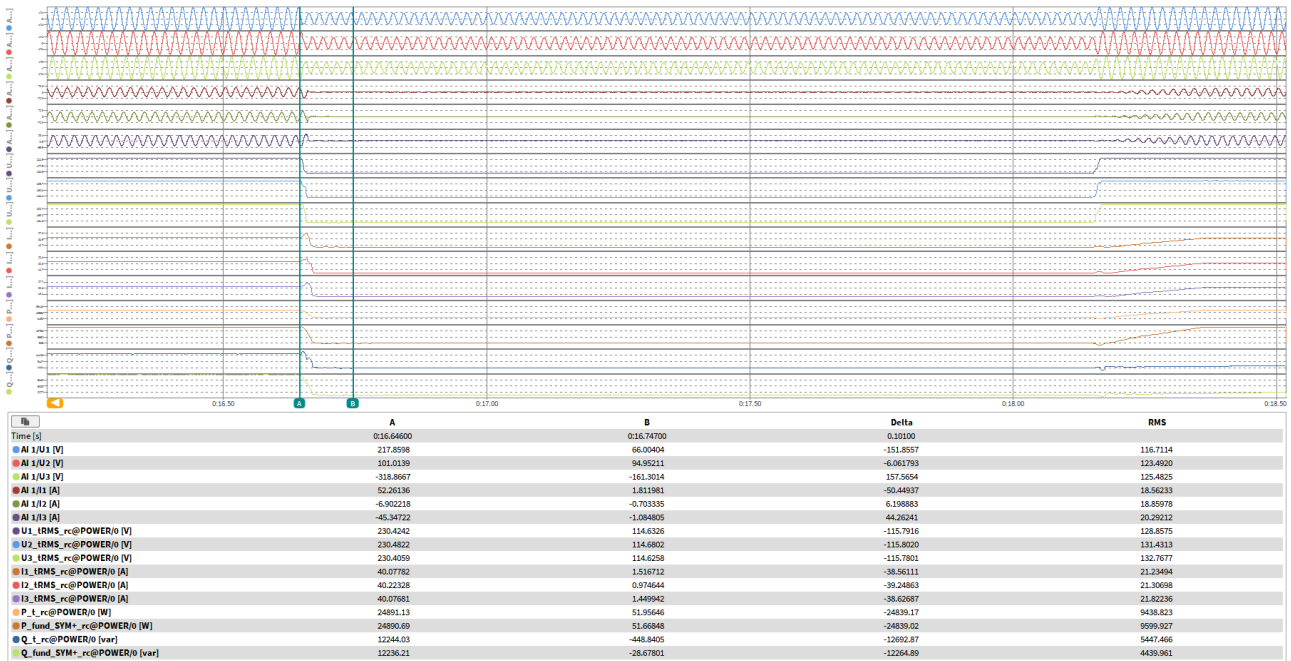

t1+100ms

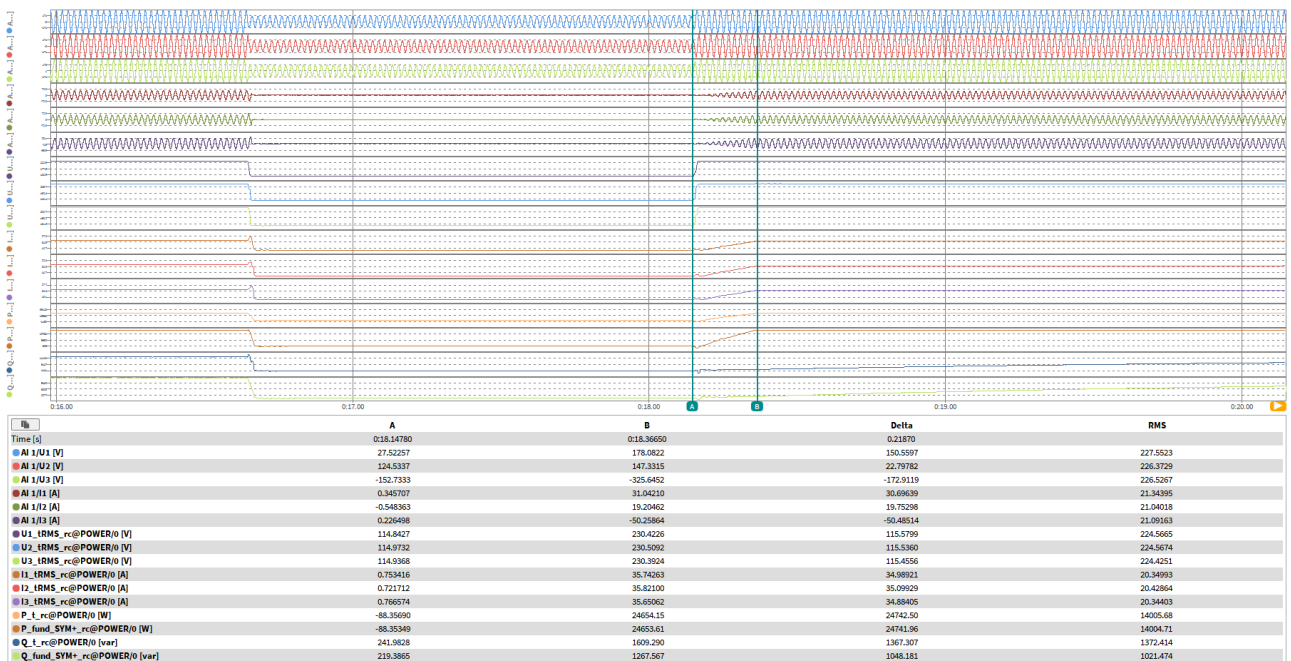

Active power rising time

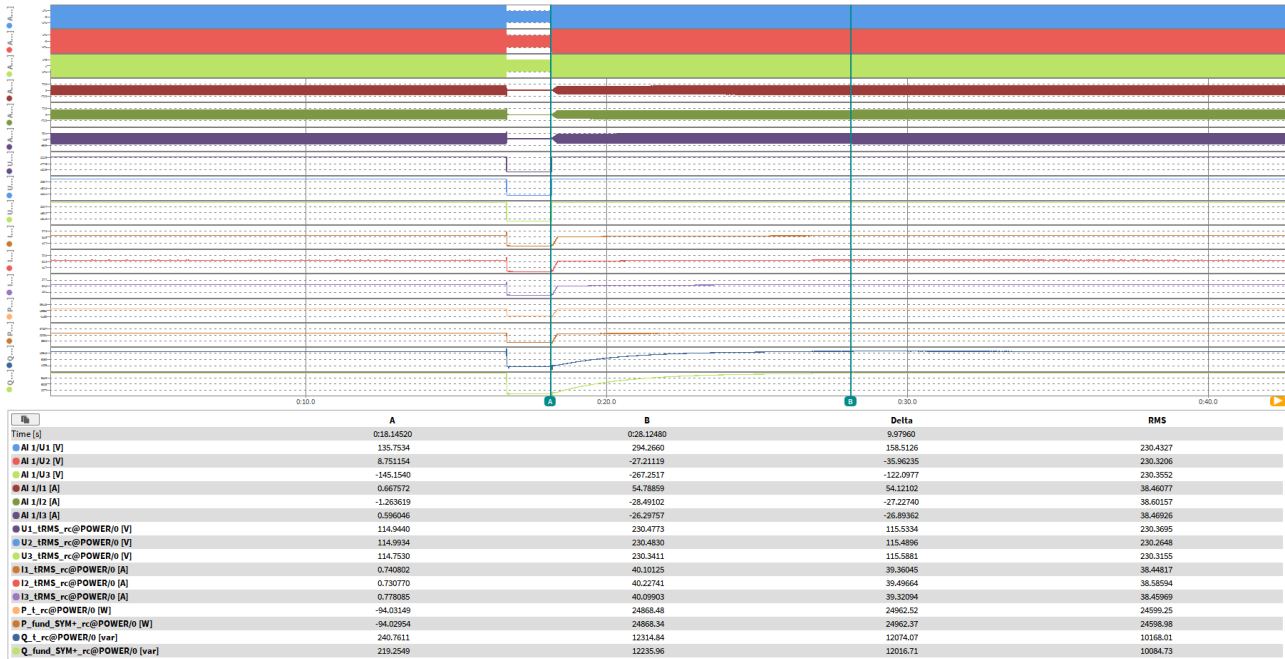

Reactive power rising time

Condition						Measurement
No.	Parameter	Phase ref.	Time ref.	unit		
General Info.	0	Test number	--	--	--	2.3
	1	Date	--	--	dd.mm.yyyy	08.06.2025
	2	Time (start of test)	--	--	hh:mm:ss.f	17:14:28
	3	Fault type (phase)	--	--		D1
	4	Setting voltage depth	Line to line	--	p.u.	0.50
	5	Setting dip duration		--		1500
	6	Point of fault entry	Total	--	ms	16281
	7	Point of fault clearance	Total	--	ms	17789
	8	Fault duration in empty load test	Total	--	ms	1601
	9	Voltage depth/height in empty load test	Total	t1+100ms to t2 and t1-10s to t1	p.u.	0.499
10	Pos.		p.u.		1.000	
Before dip <t1	11	Voltage	Line to neutral	t1-100s to t1	p.u.	1.003
	12	Current	Pos.	t1-500ms to t1-100ms	p.u.	1.094
	13	Active power	Total	t1-10s to t1	p.u.	0.983
	14		Pos.			0.983
	15	Reactive power	Total	t1-10s to t1	p.u.	0.486
	16		Pos.			0.486
17	Cosφ	--	t1-10s to t1	--	0.896	
During dip t1 to t2	18	Voltage	Line to neutral	t1+100ms to t2-20ms	p.u.	0.497
	19	Line current	Phase 1	t1+60ms	p.u.	0.056
	20		Phase 2			0.080
	21		Phase 3			0.049
	22	Line current	Phase 1	t1+100ms	p.u.	0.025
	23		Phase 2			0.016
	24		Phase 3			0.034
	25	Active power	Total	t1+100ms to t2-20ms	p.u.	0.008
26	Pos.		0.006			
After dip > t2	27	Voltage	Line to neutral	t2+3s to t2+10s	p.u.	1.003
	28	Active power	Total	t2+3s to t2+10s	p.u.	0.984
	29		Pos.			0.984
	39	Active power rising time	Pos.	--	s	0.407
	31	Reactive power	Total	t2+3s to t2+10s	p.u.	0.483
	32		Pos.			0.483
	33	Reactive power rising time	Pos.	--	s	9.816
	34	PGU does not disconnect from grid till 60s after fault	--	t2 to t2+60s	Yes / No	Yes

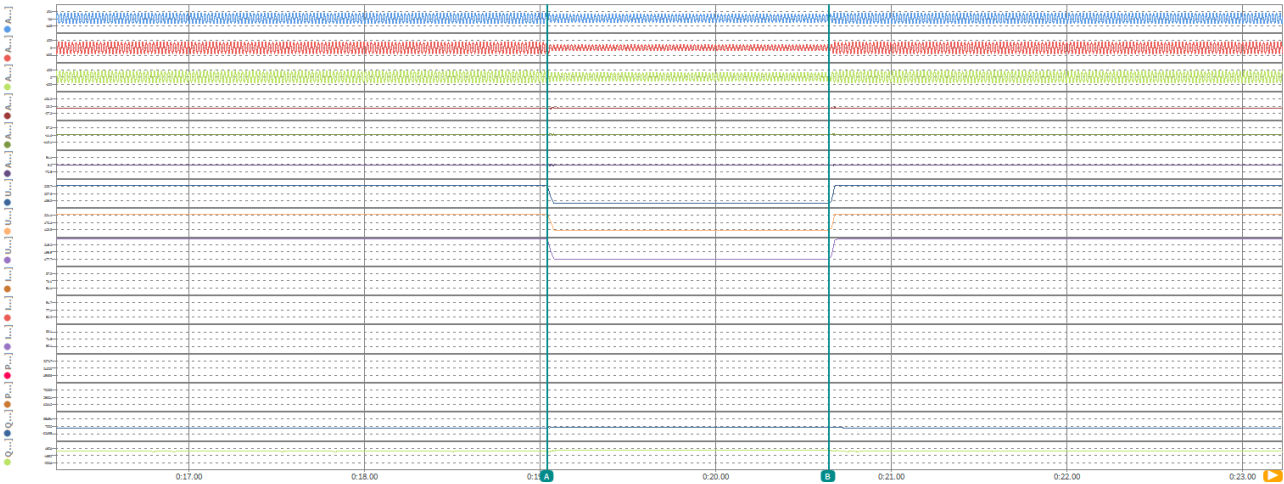
Test No. 2.3 idle test

	A	B	Delta	RMS
Time [s]	0:19.044000	0:20.645000	1.601000	
AI 1/U1 [V]	-324.0993	-229.3563	94.74302	175.3227
AI 1/U2 [V]	138.7308	-6.437634	-147.1684	116.0359
AI 1/U3 [V]	184.3801	237.4187	53.03860	175.3530
AI 1/I1 [A]	0.241006	-1.129901	-1.370907	1.383915
AI 1/I2 [A]	-0.045331	1.158683	1.204014	1.222032
AI 1/I3 [A]	-0.073785	0.081188	0.154972	1.230354
U1_IRMS@POWER/0 [V]	229.9937	174.8016	-55.19205	176.6468
U2_IRMS@POWER/0 [V]	229.9224	114.9377	-114.9848	119.9966
U3_IRMS@POWER/0 [V]	229.9133	174.7067	-55.20660	176.5827
I1_IRMS_rc@POWER/0 [A]	0.437068	1.192756	0.755688	1.380368
I2_IRMS_rc@POWER/0 [A]	0.448086	0.616071	0.367985	1.218028
I3_IRMS_rc@POWER/0 [A]	0.427962	1.021406	0.593444	1.226311
P_t_rc@POWER/0 [W]	-25.63596	-31.06049	-5.424534	277.2531
P_fund_SYM+rc@POWER/0 [W]	-26.21505	-44.69857	-18.48352	302.1170
Q_t_rc@POWER/0 [var]	-300.8504	479.7242	780.5746	545.0747
Q_fund_SYM+rc@POWER/0 [var]	-56.43849	397.2321	453.6705	393.9124

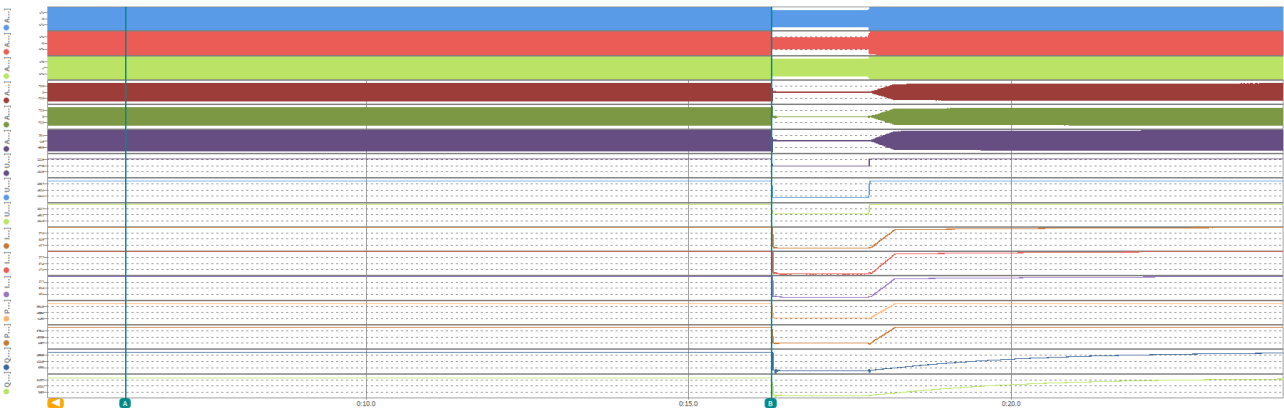
Test No. 2.3 with PGU

	A	B	Delta	RMS
Time [s]	6.27800	0:16.28200	0:10.09400	
AI 1/U1 [V]	-125.9508	244.1228	369.1735	230.9813
AI 1/U2 [V]	-199.8139	-309.8841	-110.0702	230.9016
AI 1/U3 [V]	323.5076	65.49240	-258.0152	231.0056
AI 1/I1 [A]	-84.14984	43.02264	127.1725	79.06485
AI 1/I2 [A]	-22.10140	-112.7482	-90.64675	79.56838
AI 1/I3 [A]	106.2989	69.73744	-36.56149	79.20560
U1_IRMS_rc@POWER/0 [V]	231.1428	230.3065	-0.836288	231.0124
U2_IRMS_rc@POWER/0 [V]	230.8136	234.0943	3.280746	230.8133
U3_IRMS_rc@POWER/0 [V]	231.0002	228.4268	-2.573410	231.0029
I1_IRMS_rc@POWER/0 [A]	78.99335	78.06556	-0.927788	79.07520
I2_IRMS_rc@POWER/0 [A]	79.50459	80.61207	1.107483	79.56768
I3_IRMS_rc@POWER/0 [A]	79.10127	79.45983	0.358559	79.19558
P_t_rc@POWER/0 [W]	49189.95	49276.19	88.23438	49226.25
P_fund_SYM+rc@POWER/0 [W]	49189.69	49226.98	37.28996	49225.99
Q_t_rc@POWER/0 [var]	24338.65	24277.94	-60.70997	24377.83
Q_fund_SYM+rc@POWER/0 [var]	24331.12	24403.69	72.57227	24370.10

t1-10s to t1

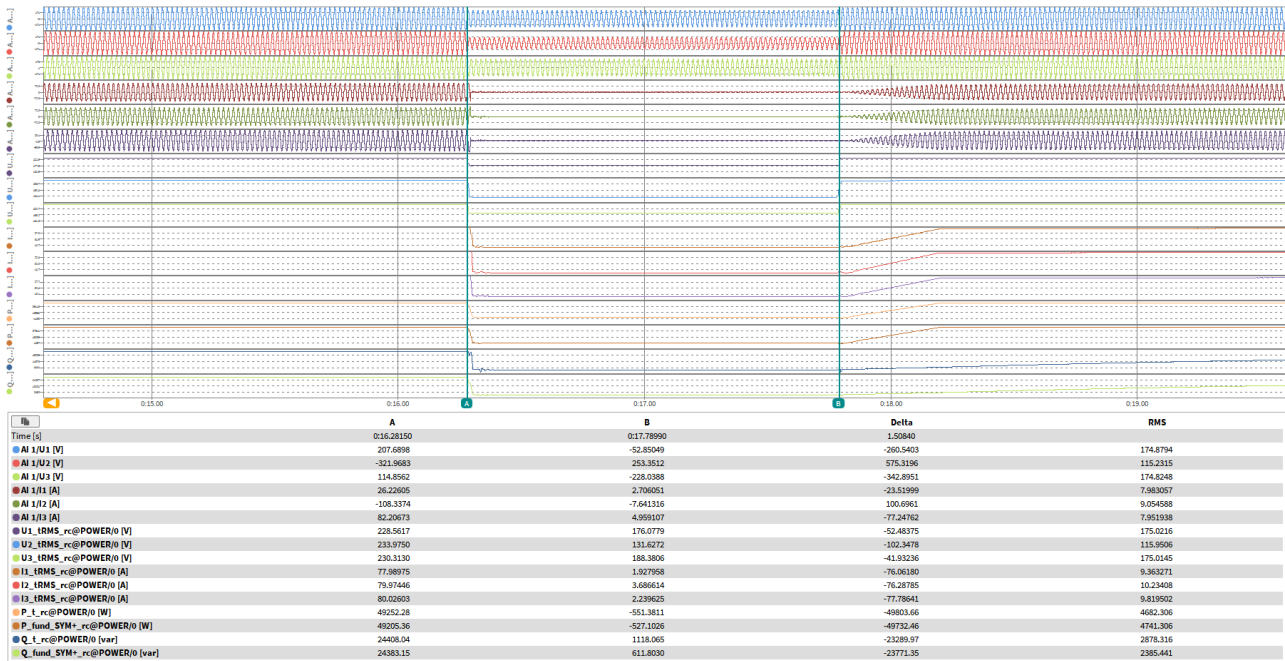

t1 to t2

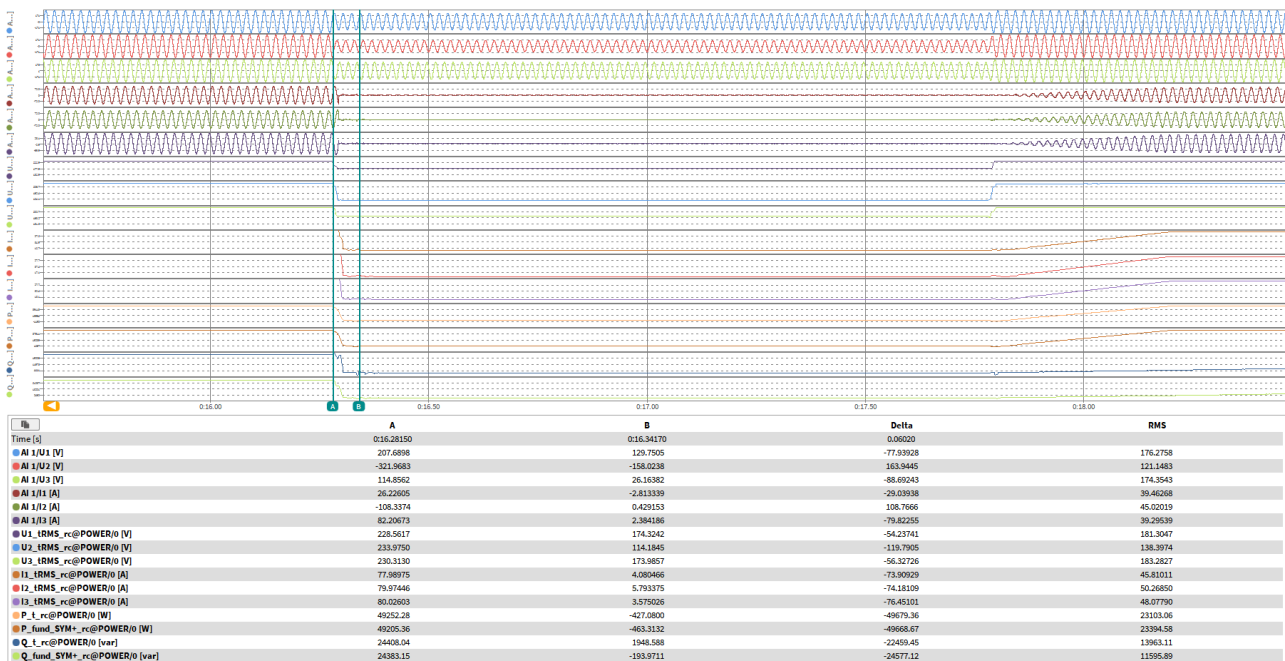

t1+60ms

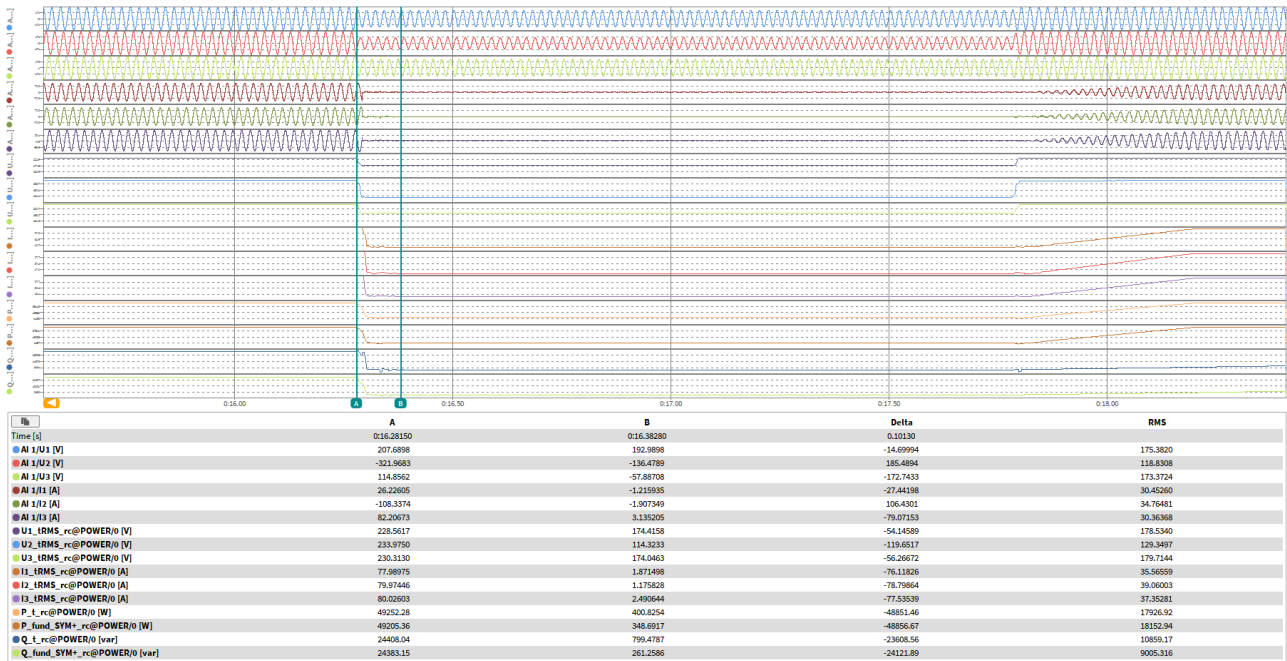

t1+100ms

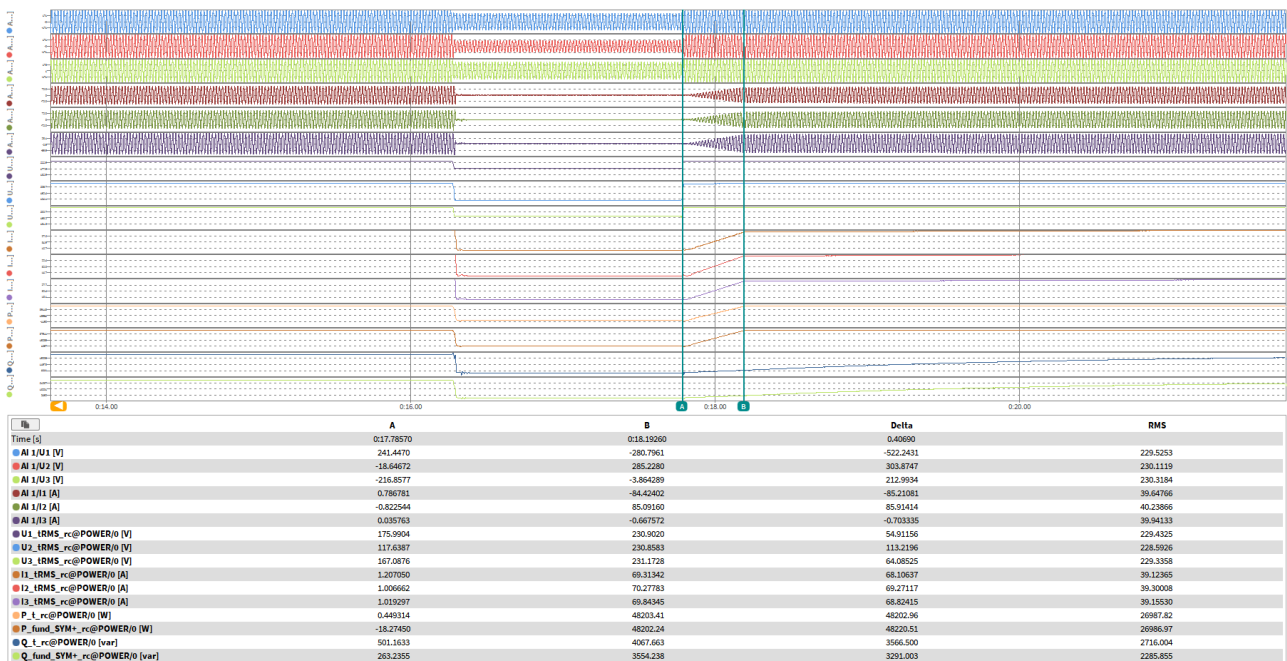

Active power rising time

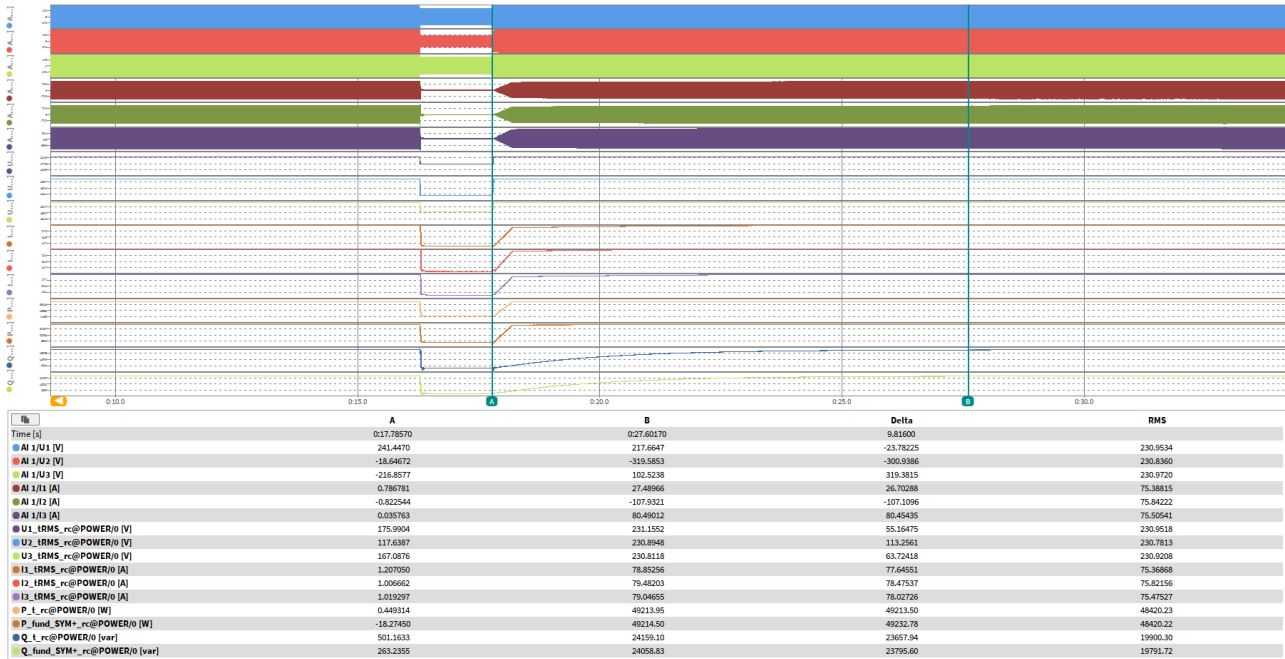

Reactive power rising time

Condition						Measurement
No.	Parameter	Phase ref.	Time ref.	unit		
General Info.	0	Test number	--	--	--	2.4
	1	Date	--	--	dd.mm.yyyy	08.06.2025
	2	Time (start of test)	--	--	hh:mm:ss.f	17:12:22
	3	Fault type (phase)	--	--		D1
	4	Setting voltage depth	Line to line	--	p.u.	0.50
	5	Setting dip duration		--		1500
	6	Point of fault entry	Total	--	ms	16041
	7	Point of fault clearance	Total	--	ms	17546
	8	Fault duration in empty load test	Total	--	ms	1601
	9	Voltage depth/height in empty load test	Total	t1+100ms to t2 and t1-10s to t1	p.u.	0.499
10	Pos.		p.u.		1.000	
Before dip <t1	11	Voltage	Line to neutral	t1-100s to t1	p.u.	1.002
	12	Current	Pos.	t1-500ms to t1-100ms	p.u.	0.554
	13	Active power	Total	t1-10s to t1	p.u.	0.497
	14		Pos.			0.497
	15	Reactive power	Total	t1-10s to t1	p.u.	0.244
	16		Pos.			0.244
17	Cosφ	--	t1-10s to t1	--	0.897	
During dip t1 to t2	18	Voltage	Line to neutral	t1+100ms to t2-20ms	p.u.	0.498
	19	Line current	Phase 1	t1+60ms	p.u.	0.053
	20		Phase 2			0.074
	21		Phase 3			0.041
	22	Line current	Phase 1	t1+100ms	p.u.	0.012
	23		Phase 2			0.018
	24		Phase 3			0.022
	25	Active power	Total	t1+100ms to t2-20ms	p.u.	0.005
26	Pos.		0.005			
After dip > t2	27	Voltage	Line to neutral	t2+3s to t2+10s	p.u.	1.002
	28	Active power	Total	t2+3s to t2+10s	p.u.	0.496
	29		Pos.			0.496
	39	Active power rising time	Pos.	--	s	0.219
	31	Reactive power	Total	t2+3s to t2+10s	p.u.	0.246
	32		Pos.			0.245
	33	Reactive power rising time	Pos.	--	s	9.985
	34	PGU does not disconnect from grid till 60s after fault	--	t2 to t2+60s	Yes / No	Yes

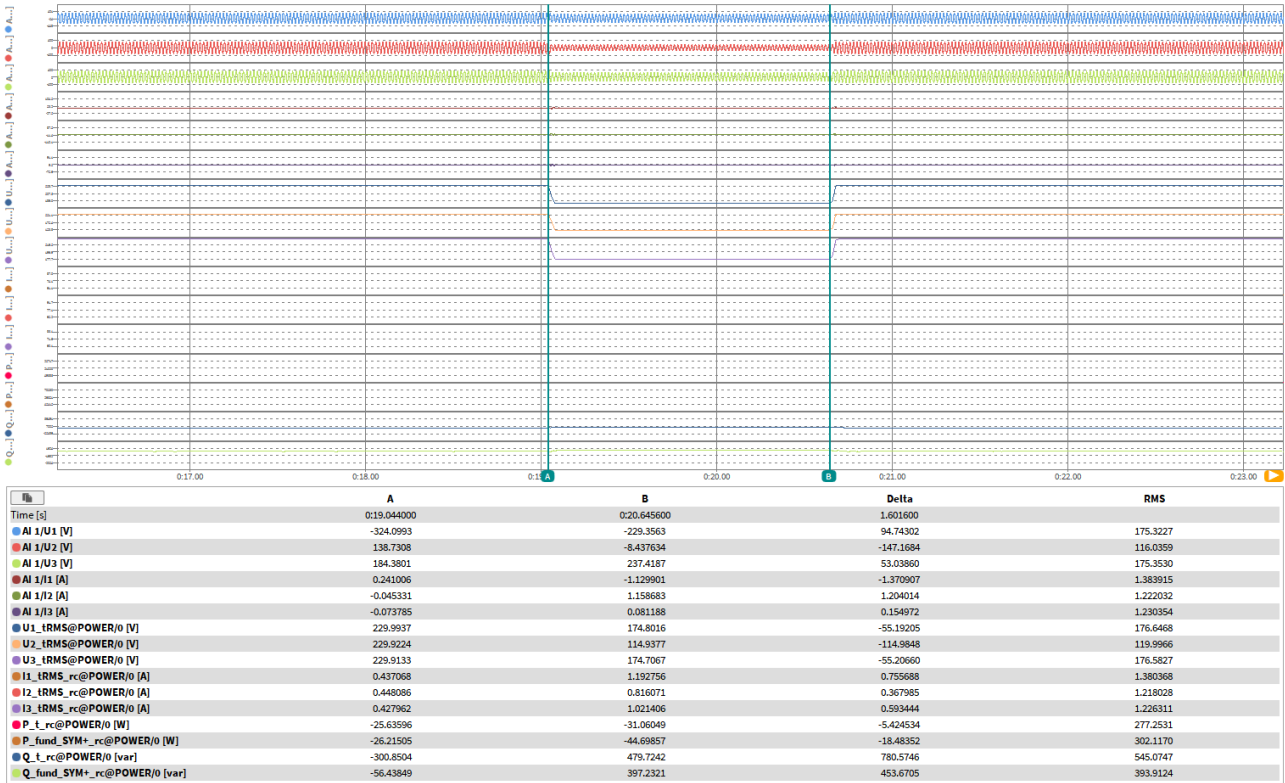
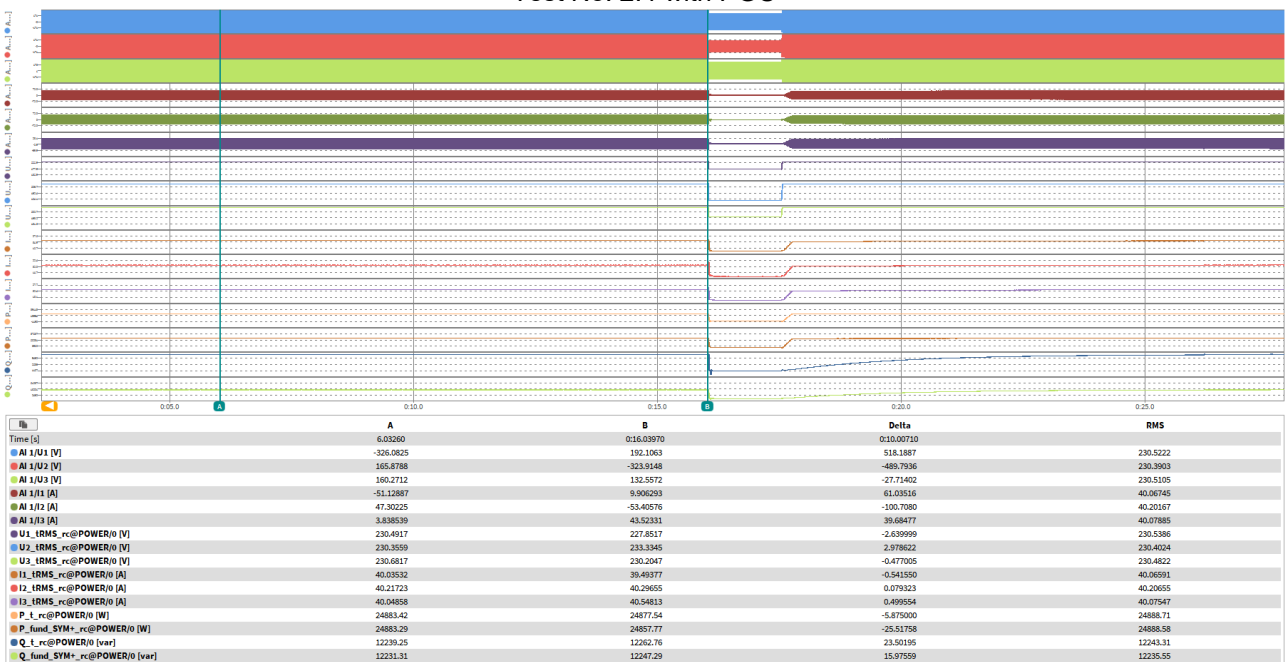
Test No. 2.4 idle test

Test No. 2.4 with PGU

t1-10s to t1

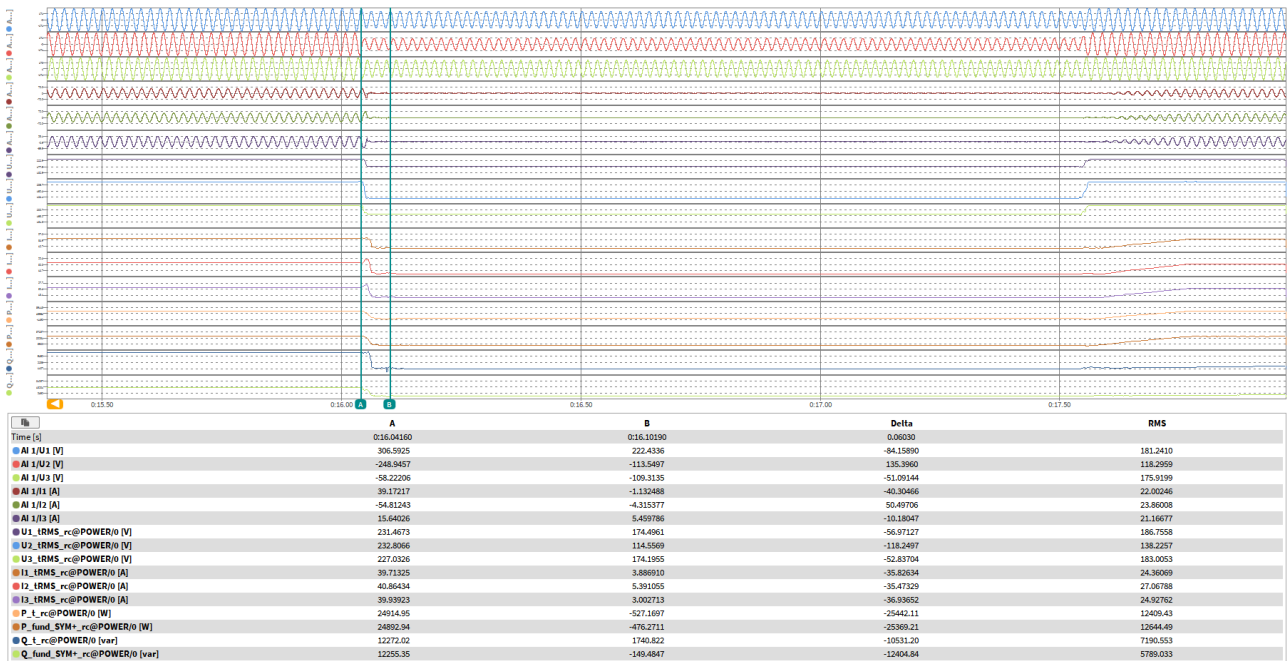

t1 to t2



t1+60ms

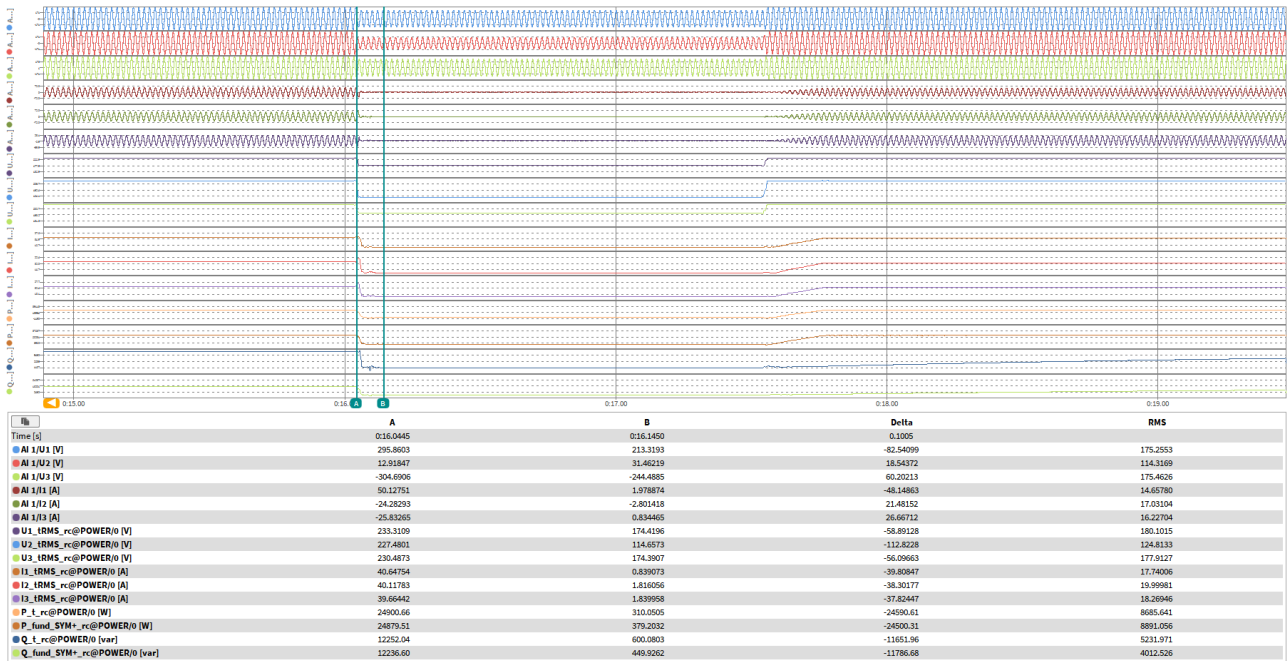

t1+100ms

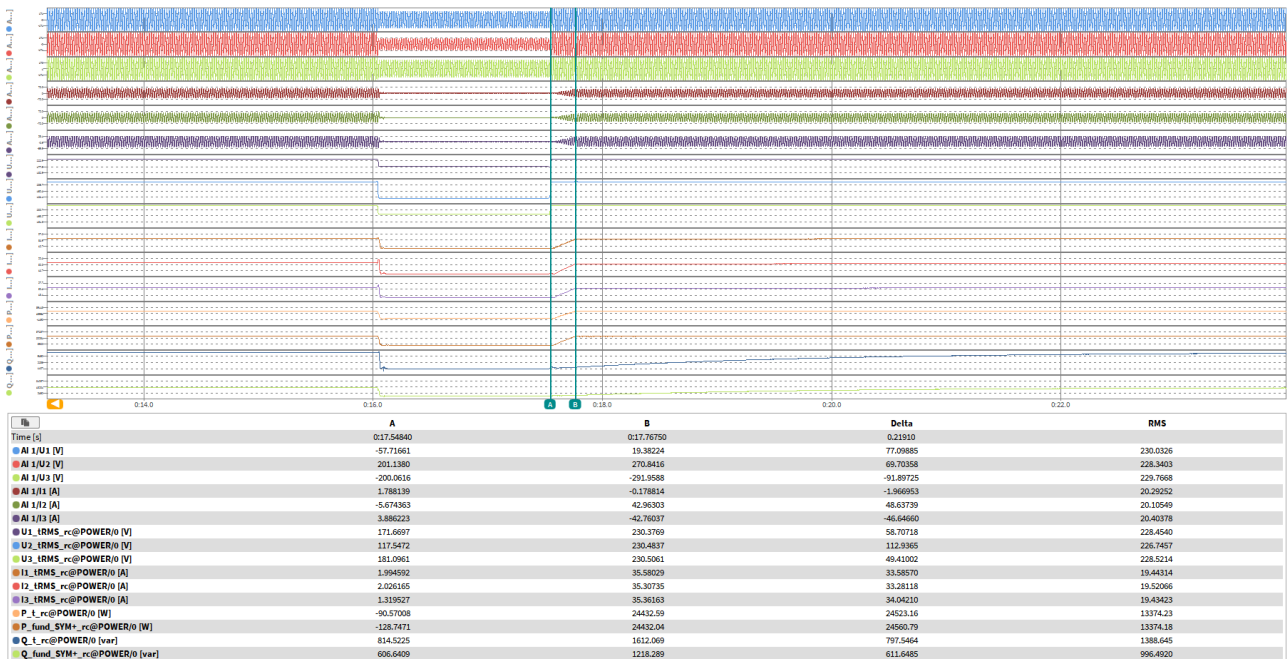

Active power rising time

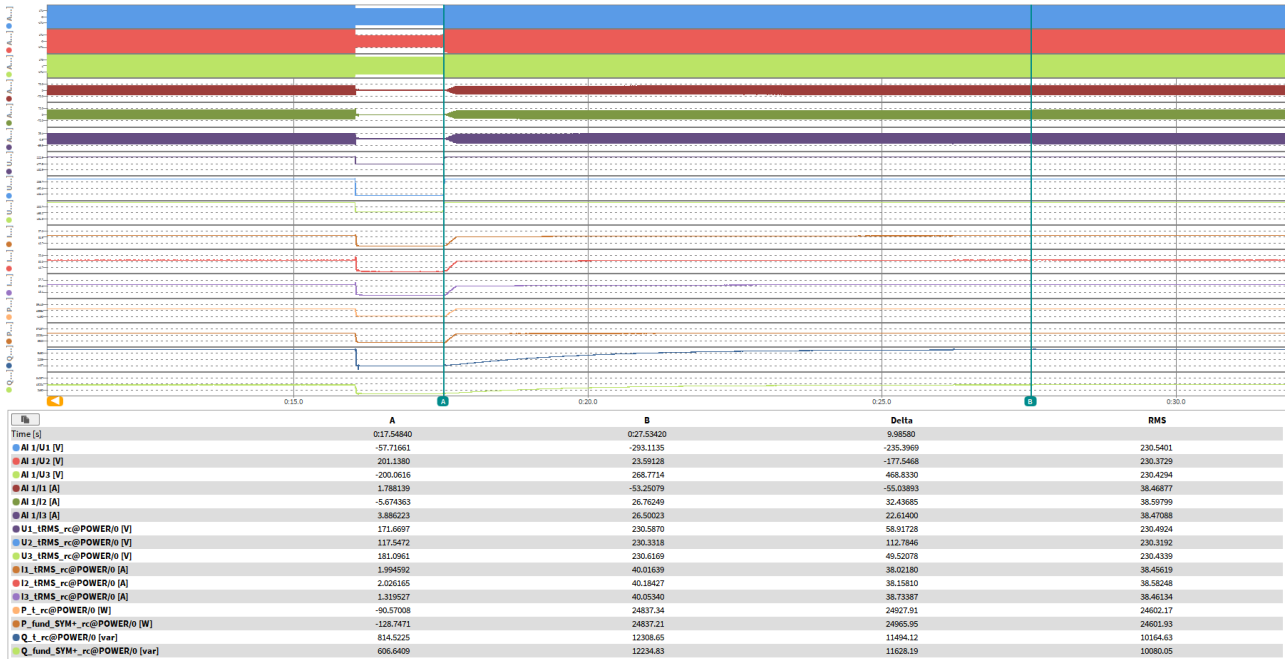

Reactive power rising time

Condition						Measurement
No.	Parameter	Phase ref.	Time ref.	unit		
General Info.	0	Test number	--	--	--	3.1
	1	Date	--	--	dd.mm.yyyy	08.06.2025
	2	Time (start of test)	--	--	hh:mm:ss.f	17:28:22
	3	Fault type (phase)	--	--		A
	4	Setting voltage depth	Line to line	--	p.u.	0.50
	5	Setting dip duration		--		1500
	6	Point of fault entry	Total	--	ms	15842
	7	Point of fault clearance	Total	--	ms	17345
	8	Fault duration in empty load test	Total	--	ms	1602
	9	Voltage depth/height in empty load test	Total	t1+100ms to t2 and t1-10s to t1	p.u.	0.500
10	Pos.		p.u.		1.000	
Before dip <t1	11	Voltage	Line to neutral	t1-100s to t1	p.u.	1.004
	12	Current	Pos.	t1-500ms to t1-100ms	p.u.	1.009
	13	Active power	Total	t1-10s to t1	p.u.	0.992
	14		Pos.			0.992
	15	Reactive power	Total	t1-10s to t1	p.u.	-0.471
	16		Pos.			-0.471
17	Cosφ	--	t1-10s to t1	--	0.903	
During dip t1 to t2	18	Voltage	Line to neutral	t1+100ms to t2-20ms	p.u.	0.500
	19	Line current	Phase 1	t1+60ms	p.u.	0.050
	20		Phase 2			0.032
	21		Phase 3			0.036
	22	Line current	Phase 1	t1+100ms	p.u.	0.022
	23		Phase 2			0.020
	24		Phase 3			0.008
	25	Active power	Total	t1+100ms to t2-20ms	p.u.	0.003
26	Pos.		0.003			
After dip > t2	27	Voltage	Line to neutral	t2+3s to t2+10s	p.u.	1.003
	28	Active power	Total	t2+3s to t2+10s	p.u.	0.993
	29		Pos.			0.993
	39	Active power rising time	Pos.	--	s	0.408
	31	Reactive power	Total	t2+3s to t2+10s	p.u.	-0.464
	32		Pos.			-0.464
	33	Reactive power rising time	Pos.	--	s	9.914
	34	PGU does not disconnect from grid till 60s after fault	--	t2 to t2+60s	Yes / No	Yes

Test No. 3.1 idle test

	A	B	Delta	RMS
Time [s]	0:19:208100	0:20:810500	1.602400	
AI 1/U1 [V]	-311.5921	-81.66886	229.9233	-
AI 1/U2 [V]	74.09382	-81.21181	-155.3056	115.0909
AI 1/U3 [V]	237.0441	162.4684	-74.57567	115.7289
AI 1/I1 [A]	0.634397	-0.486171	-1.120567	1.678176
AI 1/I2 [A]	-0.832112	1.087157	1.919270	1.528758
AI 1/I3 [A]	0.307685	-0.467175	-0.774860	1.391357
U1_IRMS@POWER/0 [V]	229.9949	115.0014	-114.9935	119.1771
U2_IRMS@POWER/0 [V]	229.9238	114.9383	-114.9855	119.1272
U3_IRMS@POWER/0 [V]	229.9237	114.8881	-115.0356	119.0879
I1_IRMS_rc@POWER/0 [A]	0.438454	0.752216	0.313762	1.681477
I2_IRMS_rc@POWER/0 [A]	0.441493	0.753501	0.312008	1.539864
I3_IRMS_rc@POWER/0 [A]	0.423561	0.726040	0.302479	1.392510
P_t_rc@POWER/0 [W]	-31.18065	-75.91720	-44.73655	332.4061
P_fund_SYM+rc@POWER/0 [W]	-31.39565	-76.21722	-44.82056	406.9595
Q_t_rc@POWER/0 [var]	-298.1195	245.0554	543.1749	580.8619
Q_fund_SYM+rc@POWER/0 [var]	-35.27425	217.7638	253.0381	218.4681

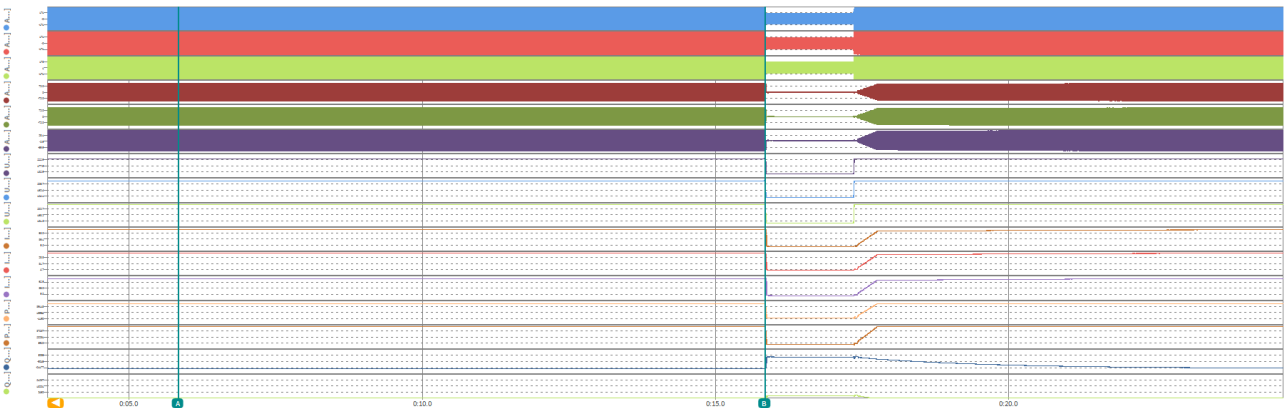
Test No. 3.1 with PGU

	A	B	Delta	RMS
Time [s]	5.841800	0:15.842800	0:10.001000	
AI 1/U1 [V]	-287.5204	-230.9523	56.56815	230.9226
AI 1/U2 [V]	9.977341	-84.81277	-94.80912	230.7890
AI 1/U3 [V]	277.2968	315.5132	88.21635	230.8941
AI 1/I1 [A]	-64.43262	-37.92048	26.51215	79.09571
AI 1/I2 [A]	-46.26513	-72.49117	-26.22605	79.63434
AI 1/I3 [A]	110.7812	110.4832	-0.298023	79.25398
U1_IRMS_rc@POWER/0 [V]	230.9674	230.9510	-0.036407	230.9189
U2_IRMS_rc@POWER/0 [V]	230.7364	231.7770	1.040574	230.8004
U3_IRMS_rc@POWER/0 [V]	231.0018	228.9635	-1.038315	230.8863
I1_IRMS_rc@POWER/0 [A]	78.98518	79.28453	0.299355	79.09786
I2_IRMS_rc@POWER/0 [A]	79.67838	79.81468	0.136307	79.63619
I3_IRMS_rc@POWER/0 [A]	79.21512	78.84079	-0.374329	79.24991
P_t_rc@POWER/0 [W]	49619.65	49626.83	7.179688	49644.02
P_fund_SYM+rc@POWER/0 [W]	49619.50	49628.69	9.189375	49643.04
Q_t_rc@POWER/0 [var]	-2358.57	-2357.05	1.5152	2351.42
Q_fund_SYM+rc@POWER/0 [var]	-23553.36	-23565.86	-12.50781	23536.45

t1-10s to t1

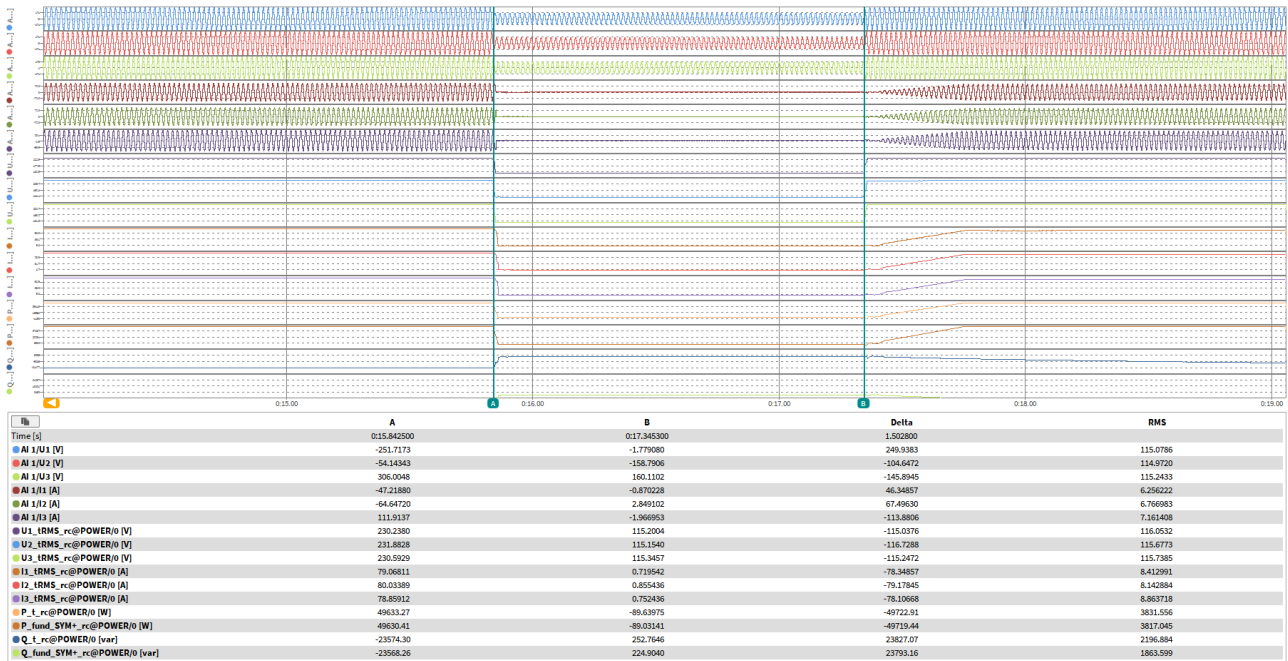

t1 to t2

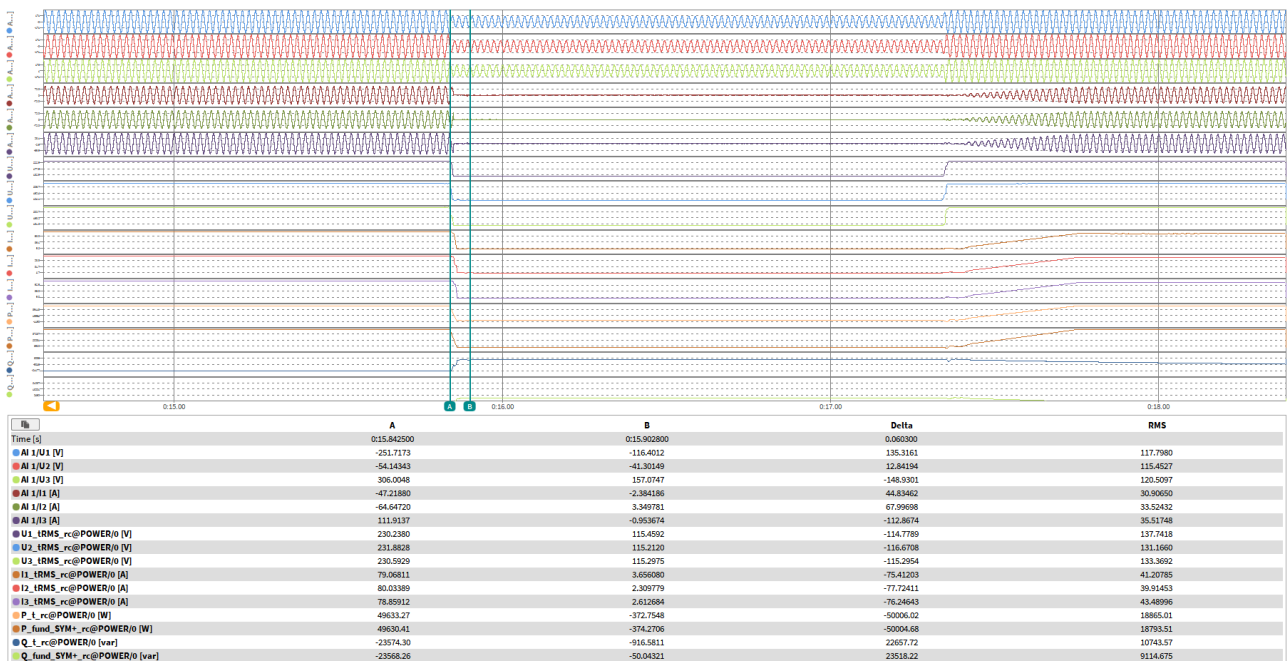

t1+60ms

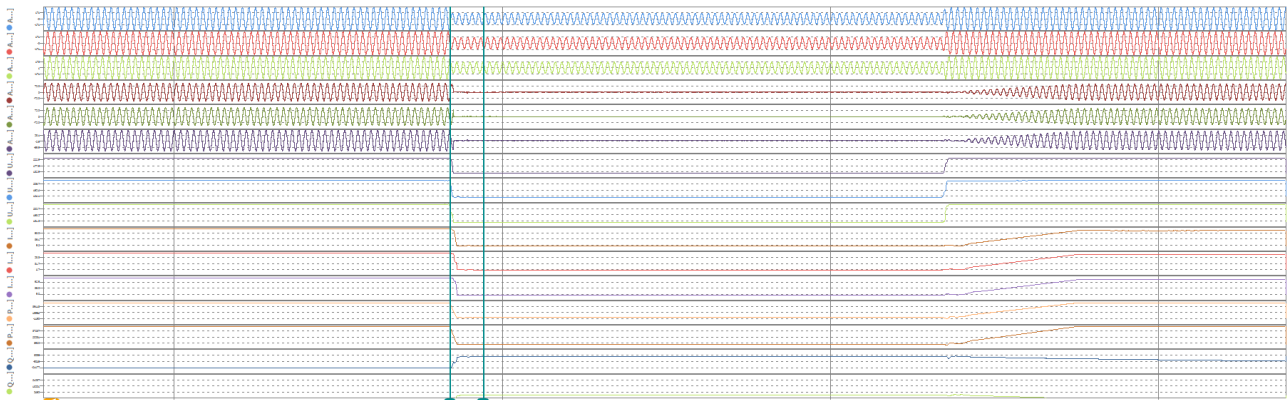

	A	B	Delta	RMS
Time [s]	0:15:842500	0:15:843800	0.001300	
AI 1/U1 [V]	-251.7173	-74.98479	176.7326	116.6197
AI 1/U2 [V]	-54.14343	-87.84271	-33.69928	115.0006
AI 1/U3 [V]	306.0048	162.4453	-143.5595	118.9352
AI 1/I1 [A]	-47.21880	-2.646446	44.57236	23.89423
AI 1/I2 [A]	-64.64720	2.217293	66.86449	25.89523
AI 1/I3 [A]	111.9137	0.463995	-111.4607	27.49432
U1_IRMS_rc@POWER() [V]	230.2380	115.4536	-114.7854	129.2867
U2_IRMS_rc@POWER() [V]	231.8828	115.1739	-116.7090	125.0701
U3_IRMS_rc@POWER() [V]	230.5929	115.2073	-115.3856	126.4647
I1_IRMS_rc@POWER() [A]	79.06811	1.608728	-77.45938	32.00487
I2_IRMS_rc@POWER() [A]	80.03389	1.471632	-78.56226	30.98585
I3_IRMS_rc@POWER() [A]	78.85912	0.614294	-78.24482	33.75398
P_t_rc@POWER() [W]	49633.27	198.1836	-49435.08	14637.97
P_fund_SYM+rc@POWER() [W]	49630.41	198.0512	-49432.36	14582.51
Q_t_rc@POWER() [var]	-23574.30	377.0892	23951.39	8341.851
Q_fund_SYM+rc@POWER() [var]	-23568.26	128.6381	23696.90	7074.045

t1+100ms

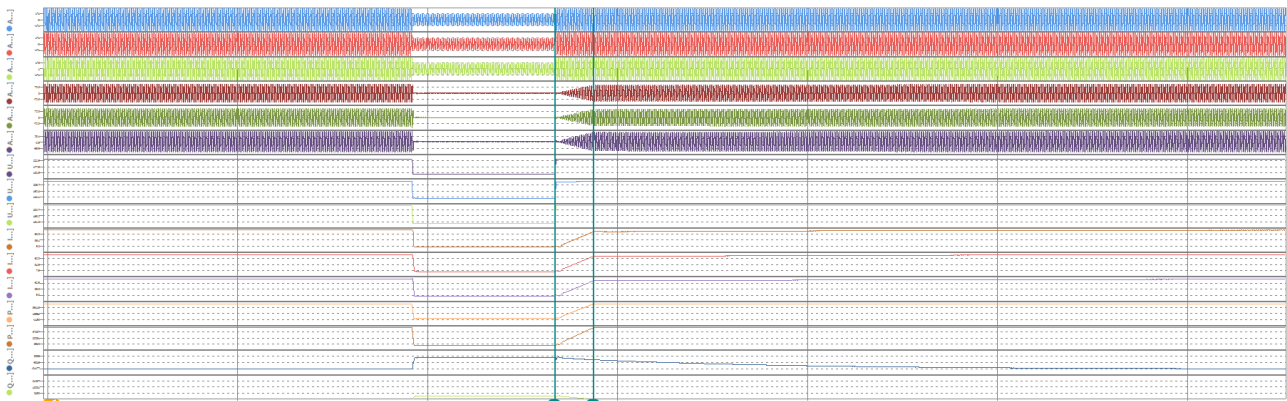

	A	B	Delta	RMS
Time [s]	0:17:36700	0:17:76700	0.400000	
AI 1/U1 [V]	-142.0331	199.0218	341.0549	227.8081
AI 1/U2 [V]	136.7866	-323.6757	-460.4622	228.1303
AI 1/U3 [V]	1.114369	124.2518	123.1375	228.4643
AI 1/I1 [A]	0.274181	69.15331	68.87913	40.35830
AI 1/I2 [A]	0.452995	-99.77818	-100.2312	40.91239
AI 1/I3 [A]	-0.727177	30.67255	31.39973	40.78561
U1_IRMS_rc@POWER() [V]	114.0192	231.0843	116.1651	226.9689
U2_IRMS_rc@POWER() [V]	114.9037	230.8317	115.9280	226.9113
U3_IRMS_rc@POWER() [V]	115.0849	230.7628	115.6779	226.9743
I1_IRMS_rc@POWER() [A]	0.766062	70.25136	69.48530	39.78455
I2_IRMS_rc@POWER() [A]	0.710450	70.87278	70.16233	39.96913
I3_IRMS_rc@POWER() [A]	0.761561	70.88640	70.12484	39.82666
P_t_rc@POWER() [W]	-91.19623	48776.55	48867.75	21479.43
P_fund_SYM+rc@POWER() [W]	-91.16429	48776.25	48867.42	21479.06
Q_t_rc@POWER() [var]	240.6092	-4136.238	-4376.847	2355.442
Q_fund_SYM+rc@POWER() [var]	217.7457	-4047.866	-4265.611	2185.262

Active power rising time

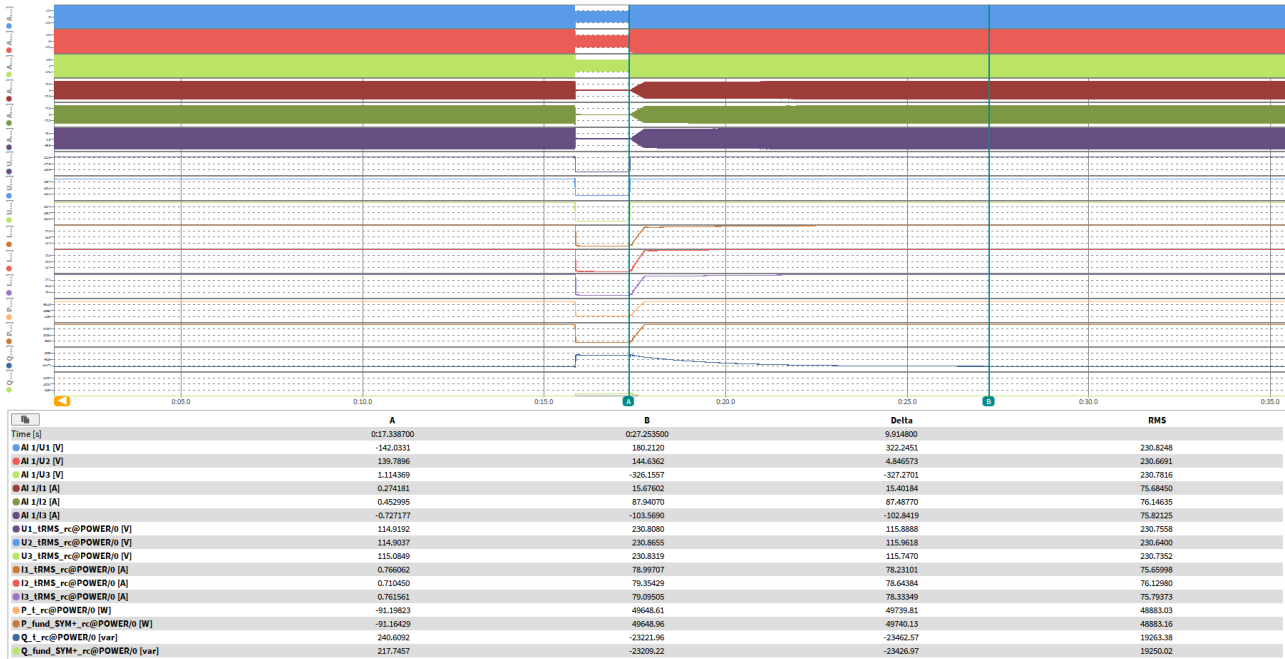

Reactive power rising time

Condition						Measurement
No.	Parameter	Phase ref.	Time ref.	unit		
General Info.	0	Test number	--	--	--	3.2
	1	Date	--	--	dd.mm.yyyy	08.06.2025
	2	Time (start of test)	--	--	hh:mm:ss.f	16:30:22
	3	Fault type (phase)	--	--		A
	4	Setting voltage depth	Line to line	--	p.u.	0.50
	5	Setting dip duration		--		1500
	6	Point of fault entry	Total	--	ms	16382
	7	Point of fault clearance	Total	--	ms	17884
	8	Fault duration in empty load test	Total	--	ms	1602
	9	Voltage depth/height in empty load test	Total	t1+100ms to t2 and t1-10s to t1	p.u.	0.500
10	Pos.		p.u.		1.000	
Before dip <t1	11	Voltage	Line to neutral	t1-100s to t1	p.u.	1.000
	12	Current	Pos.	t1-500ms to t1-100ms	p.u.	0.556
	13	Active power	Total	t1-10s to t1	p.u.	0.501
	14		Pos.			0.501
	15	Reactive power	Total	t1-10s to t1	p.u.	-0.238
	16		Pos.			-0.238
17	Cos ϕ	--	t1-10s to t1	--	0.902	
During dip t1 to t2	18	Voltage	Line to neutral	t1+100ms to t2-20ms	p.u.	0.500
	19	Line current	Phase 1	t1+60ms	p.u.	0.013
	20		Phase 2			0.018
	21		Phase 3			0.019
	22	Line current	Phase 1	t1+100ms	p.u.	0.013
	23		Phase 2			0.023
	24		Phase 3			0.015
	25	Active power	Total	t1+100ms to t2-20ms	p.u.	0.004
26	Pos.		0.004			
After dip > t2	27	Voltage	Line to neutral	t2+3s to t2+10s	p.u.	1.001
	28	Active power	Total	t2+3s to t2+10s	p.u.	0.500
	29		Pos.			0.500
	39	Active power rising time	Pos.	--	s	0.212
	31	Reactive power	Total	t2+3s to t2+10s	p.u.	-0.239
	32		Pos.			-0.239
	33	Reactive power rising time	Pos.	--	s	9.974
	34	PGU does not disconnect from grid till 60s after fault	--	t2 to t2+60s	Yes / No	Yes

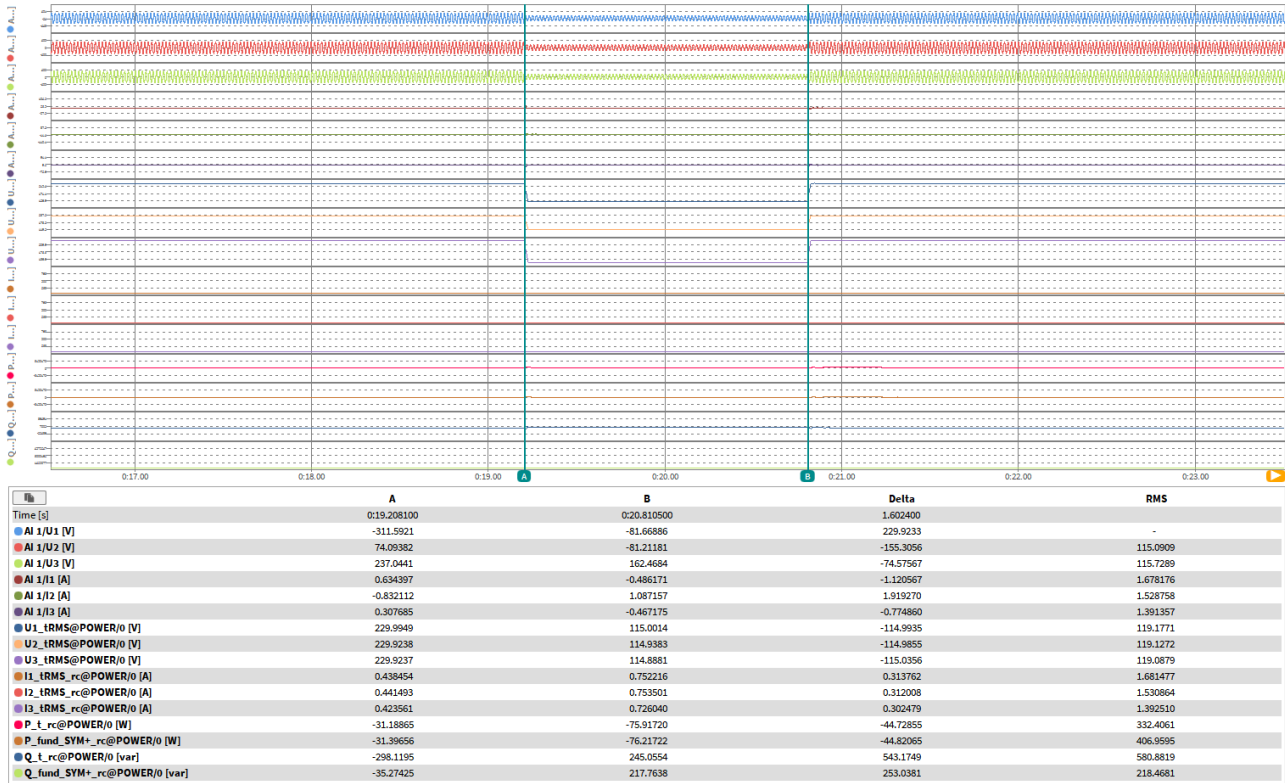
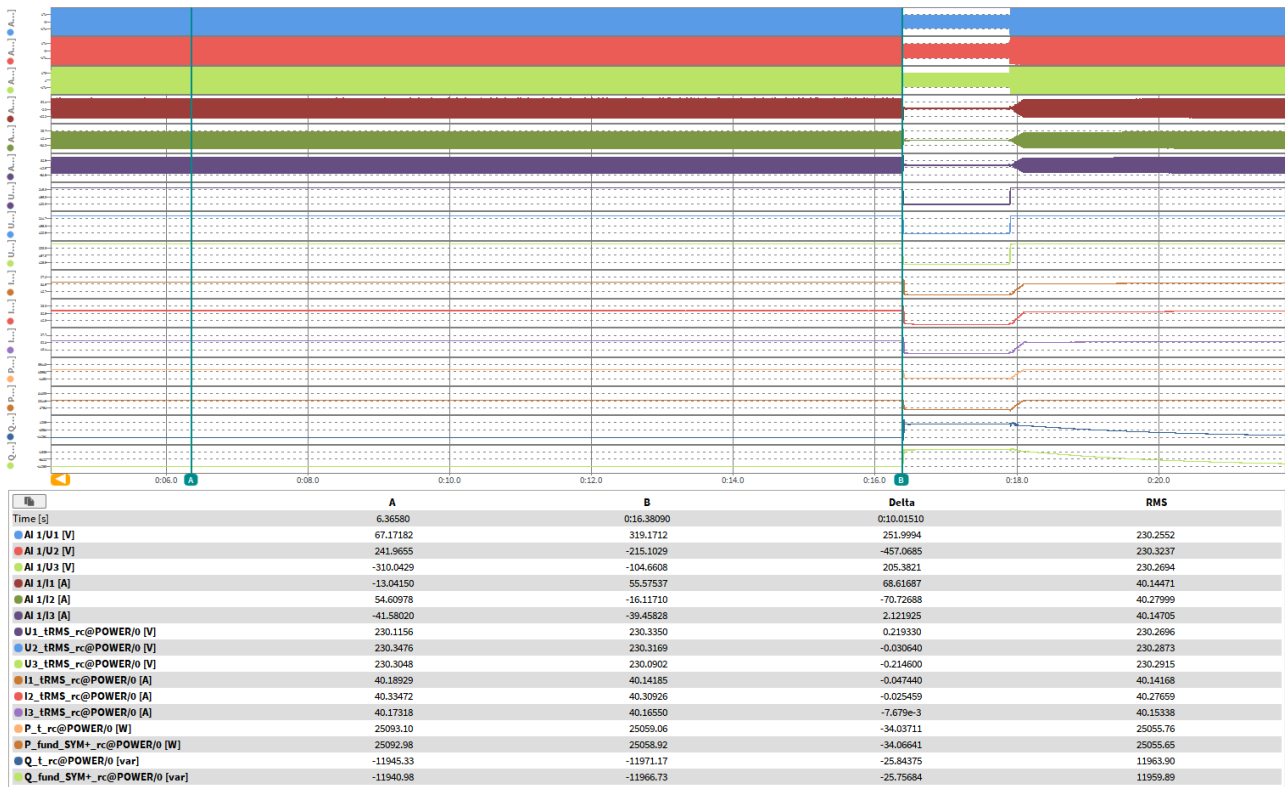
Test No. 3.2 idle test

Test No. 3.2 with PGU

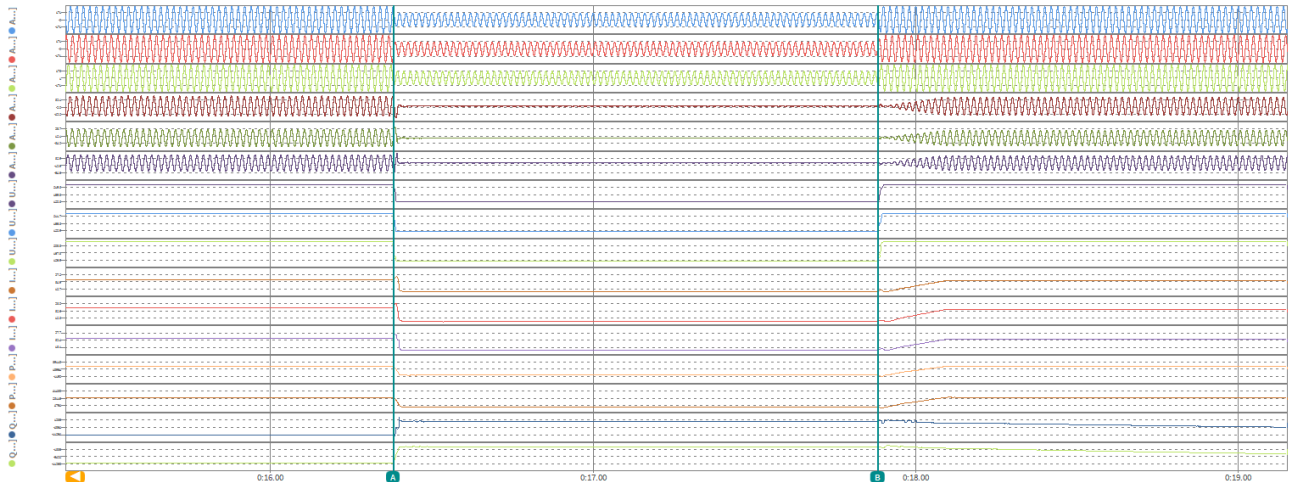
t1-10s to t1

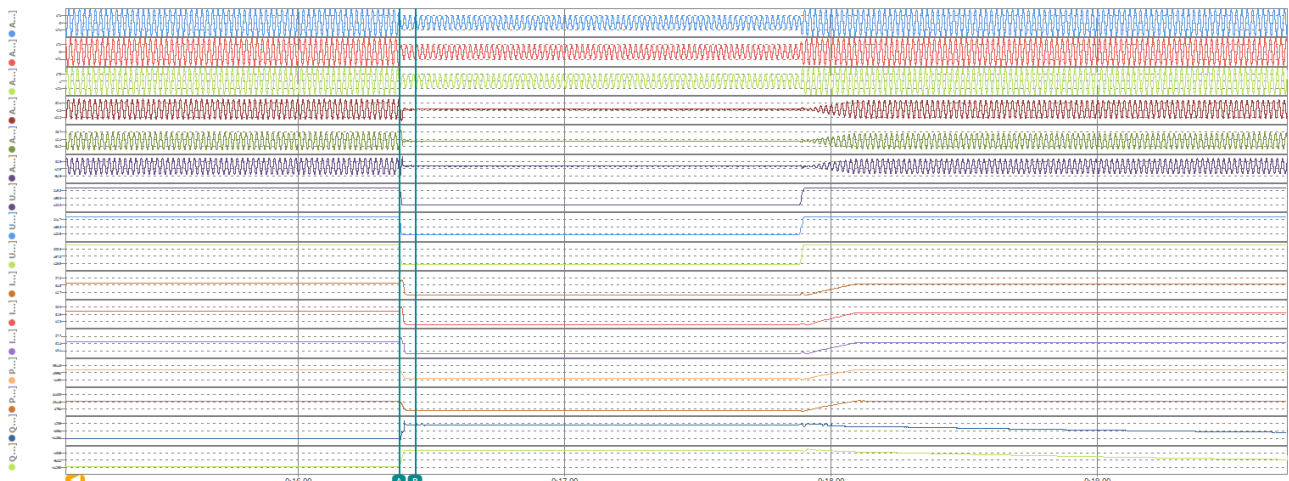

	A	B	Delta	RMS
Time [s]	0:16.38230	0:17.88440	1.50210	
AI 1/U1 [V]	316.1371	109.1027	-207.0344	115.2216
AI 1/U2 [V]	-90.12199	63.15136	153.2734	114.8884
AI 1/U3 [V]	-225.9836	-172.6129	53.37072	115.0776
AI 1/I1 [A]	44.32202	-0.226498	-44.54851	4.406038
AI 1/I2 [A]	8.630753	-1.847744	-10.47850	4.508576
AI 1/I3 [A]	-52.95277	2.086163	55.03893	4.780227
U1_IRMS_rc@POWER/0 [V]	230.2385	115.0340	-115.2046	115.9082
U2_IRMS_rc@POWER/0 [V]	230.3485	115.0113	-115.3372	115.7106
U3_IRMS_rc@POWER/0 [V]	230.1374	115.1213	-115.0161	115.4888
I1_IRMS_rc@POWER/0 [A]	40.18170	0.729382	-39.45232	5.204272
I2_IRMS_rc@POWER/0 [A]	40.30942	0.729396	-39.58003	5.086687
I3_IRMS_rc@POWER/0 [A]	40.15928	0.781539	-39.37774	5.261876
P_t_rc@POWER/0 [W]	25071.98	-81.50224	-25153.48	2151.261
P_fund_SYM+_rc@POWER/0 [W]	25071.81	-81.26592	-25153.08	2202.419
Q_t_rc@POWER/0 [var]	-11960.54	244.5400	12205.08	1215.302
Q_fund_SYM+_rc@POWER/0 [var]	-11956.25	219.2093	12175.45	890.6329

t1 to t2



	A	B	Delta	RMS
Time [s]	0:16.38230	0:16.44230	0.06000	
AI 1/U1 [V]	316.1371	158.0899	-158.0472	119.2665
AI 1/U2 [V]	-90.12199	-45.89772	44.22426	115.2050
AI 1/U3 [V]	-225.9836	-112.2174	113.7662	117.8323
AI 1/I1 [A]	44.32202	0.238419	-44.08360	21.67413
AI 1/I2 [A]	8.630753	-2.551079	-11.18183	22.15744
AI 1/I3 [A]	-52.95277	2.324581	55.27735	23.60695
U1_IRMS_rc@POWER/0 [V]	230.2385	115.2207	-115.0178	135.2570
U2_IRMS_rc@POWER/0 [V]	230.3485	115.2122	-115.1363	132.3711
U3_IRMS_rc@POWER/0 [V]	230.1374	114.9763	-115.1611	128.4969
I1_IRMS_rc@POWER/0 [A]	40.18170	0.969619	-39.21208	25.53586
I2_IRMS_rc@POWER/0 [A]	40.30942	1.323610	-38.98581	24.90998
I3_IRMS_rc@POWER/0 [A]	40.15928	1.388414	-38.77086	25.85340
P_t_rc@POWER/0 [W]	25071.98	-179.3555	-25251.33	10669.25
P_fund_SYM+_rc@POWER/0 [W]	25071.81	-179.2856	-25251.10	10923.41
Q_t_rc@POWER/0 [var]	-11960.54	384.0330	12344.58	5898.270
Q_fund_SYM+_rc@POWER/0 [var]	-11956.25	287.9064	12244.15	4284.904

t1+60ms

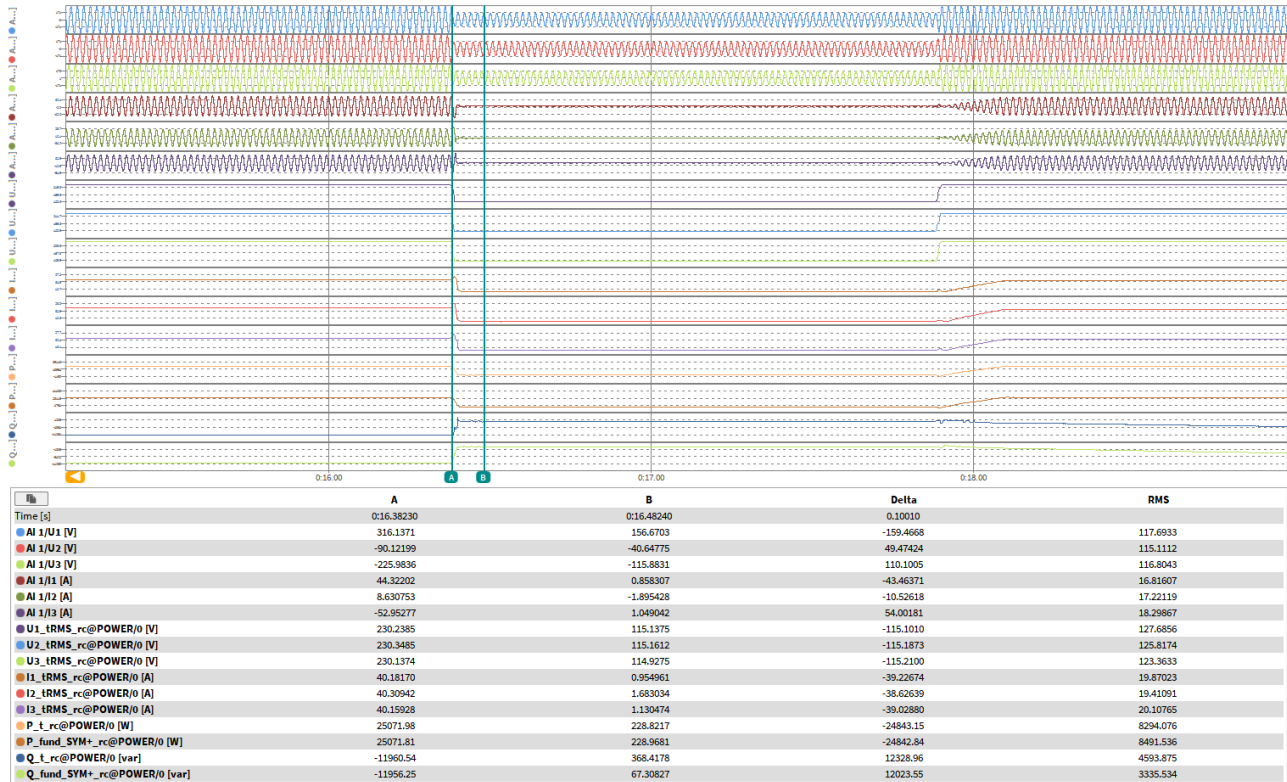

t1+100ms

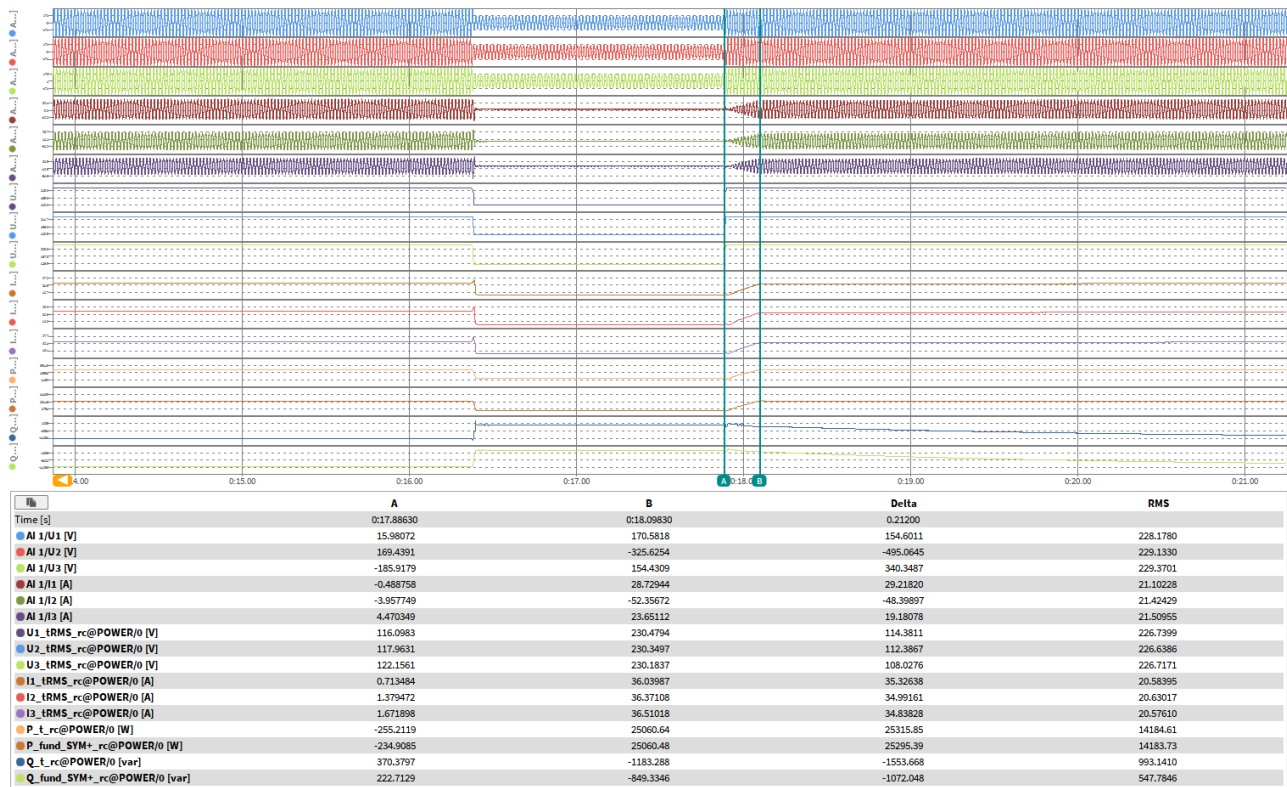

Active power rising time

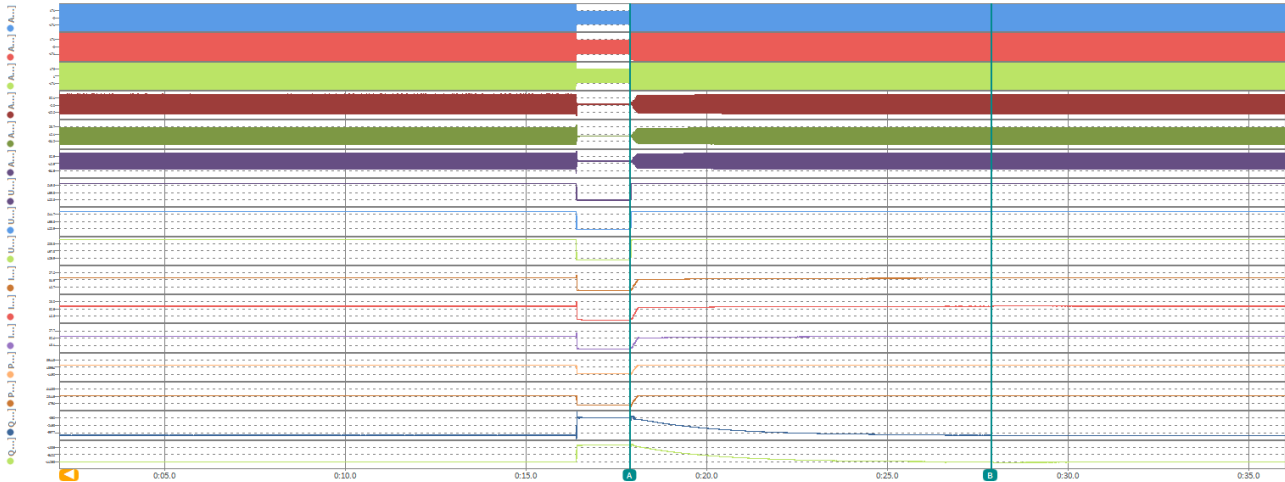

	A	B	Delta	RMS
Time [s]	0:17.88630	0:27.86100	9.97470	
AI 1/U1 [V]	15.98072	319.6469	303.6661	230.2431
AI 1/U2 [V]	169.4391	-232.9104	-382.3495	230.2822
AI 1/U3 [V]	-185.9179	-107.1401	78.77779	230.2520
AI 1/I1 [A]	-0.488758	54.71707	55.20583	38.60821
AI 1/I2 [A]	-3.957749	-14.51969	-10.56194	38.73813
AI 1/I3 [A]	4.470349	-40.20930	-44.67964	38.61355
U1_rms_rc@POWER/0 [V]	116.0983	230.3380	114.2397	230.2023
U2_rms_rc@POWER/0 [V]	117.9631	230.3171	112.3540	230.2129
U3_rms_rc@POWER/0 [V]	122.1561	230.0815	107.9255	230.2227
I1_rms_rc@POWER/0 [A]	0.713484	40.13602	39.42254	38.59482
I2_rms_rc@POWER/0 [A]	1.379472	40.27649	38.89702	38.72480
I3_rms_rc@POWER/0 [A]	1.671898	40.17570	38.50380	38.60522
P_t_rc@POWER/0 [W]	-255.2119	25045.36	25300.57	24836.98
P_fund_SYM+_rc@POWER/0 [W]	-234.9085	25045.37	25280.27	24836.94
Q_t_rc@POWER/0 [var]	370.3797	-11984.14	-12354.52	9787.800
Q_fund_SYM+_rc@POWER/0 [var]	222.7129	-11973.92	-12196.63	9775.500

Reactive power rising time

Condition						Measurement
No.	Parameter	Phase ref.	Time ref.	unit		
General Info.	0	Test number	--	--	--	3.3
	1	Date	--	--	dd.mm.yyyy	08.06.2025
	2	Time (start of test)	--	--	hh:mm:ss.f	17:18:10
	3	Fault type (phase)	--	--		D1
	4	Setting voltage depth	Line to line	--	p.u.	0.50
	5	Setting dip duration		--		1500
	6	Point of fault entry	Total	--	ms	15883
	7	Point of fault clearance	Total	--	ms	17388
	8	Fault duration in empty load test	Total	--	ms	1601
	9	Voltage depth/height in empty load test	Total	t1+100ms to t2 and t1-10s to t1	p.u.	0.499
10	Pos.		p.u.		1.000	
Before dip <t1	11	Voltage	Line to neutral	t1-100s to t1	p.u.	1.004
	12	Current	Pos.	t1-500ms to t1-100ms	p.u.	1.093
	13	Active power	Total	t1-10s to t1	p.u.	1.1023
	14		Pos.			1.095
	15	Reactive power	Total	t1-10s to t1	p.u.	-0.471
	16		Pos.			-0.471
17	Cosφ	--	t1-10s to t1	--	0.903	
During dip t1 to t2	18	Voltage	Line to neutral	t1+100ms to t2-20ms	p.u.	0.501
	19	Line current	Phase 1	t1+60ms	p.u.	0.067
	20		Phase 2			0.083
	21		Phase 3			0.052
	22	Line current	Phase 1	t1+100ms	p.u.	0.021
	23		Phase 2			0.019
	24		Phase 3			0.024
	25	Active power	Total	t1+100ms to t2-20ms	p.u.	0.003
26	Pos.		0.003			
After dip > t2	27	Voltage	Line to neutral	t2+3s to t2+10s	p.u.	1.003
	28	Active power	Total	t2+3s to t2+10s	p.u.	0.992
	29		Pos.			0.992
	39	Active power rising time	Pos.	--	s	0.426
	31	Reactive power	Total	t2+3s to t2+10s	p.u.	-0.464
	32		Pos.			-0.464
	33	Reactive power rising time	Pos.	--	s	9.842
	34	PGU does not disconnect from grid till 60s after fault	--	t2 to t2+60s	Yes / No	Yes

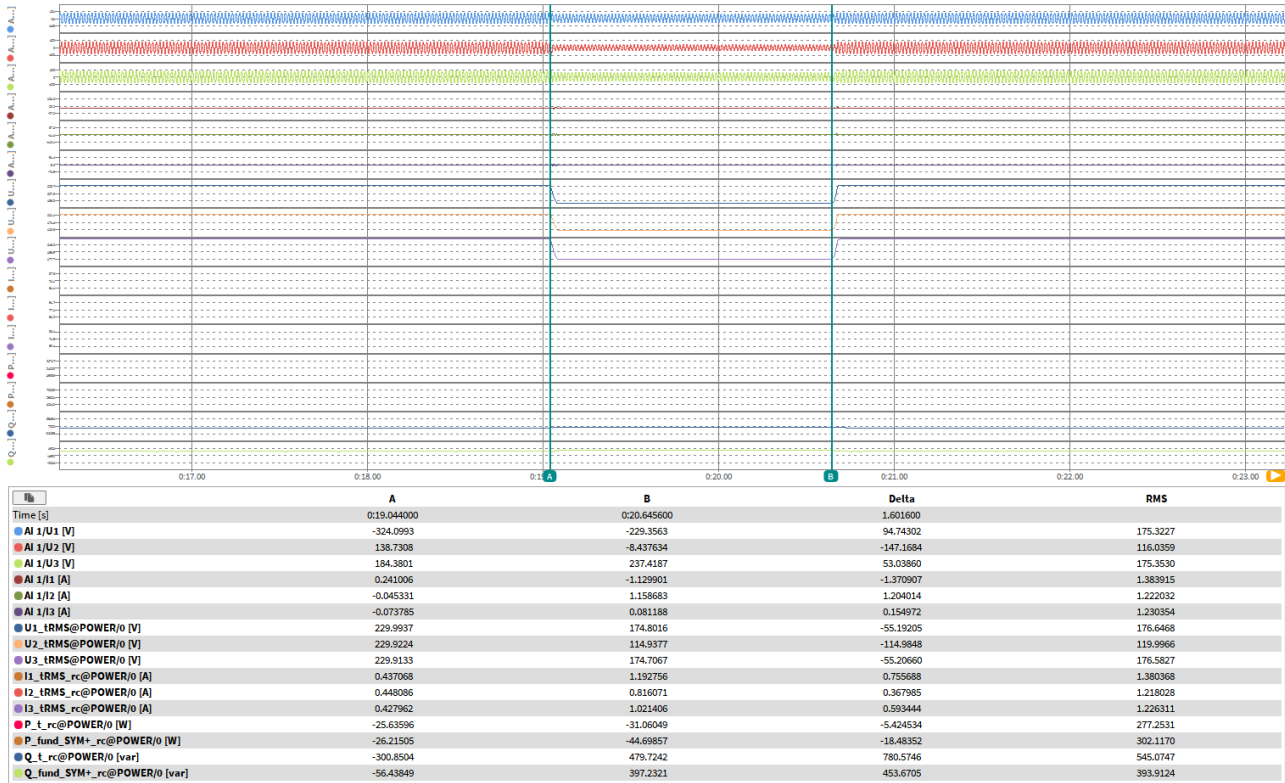
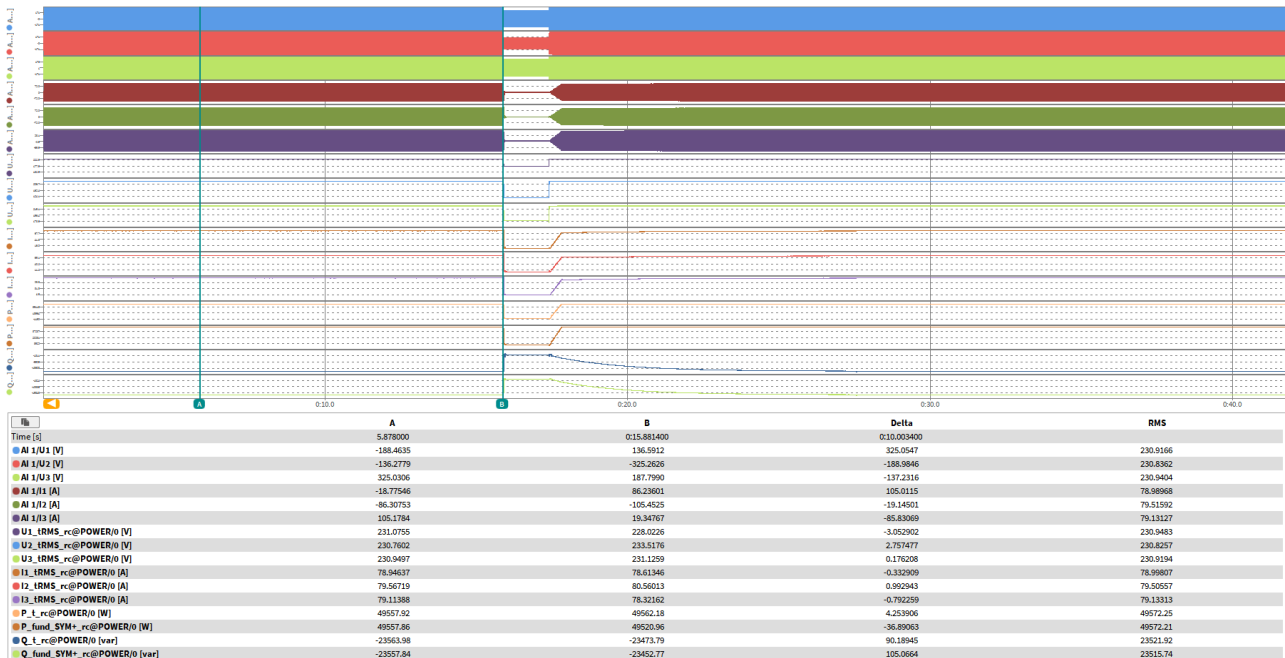
Test No. 3.3 idle test

Test No. 3.3 with PGU

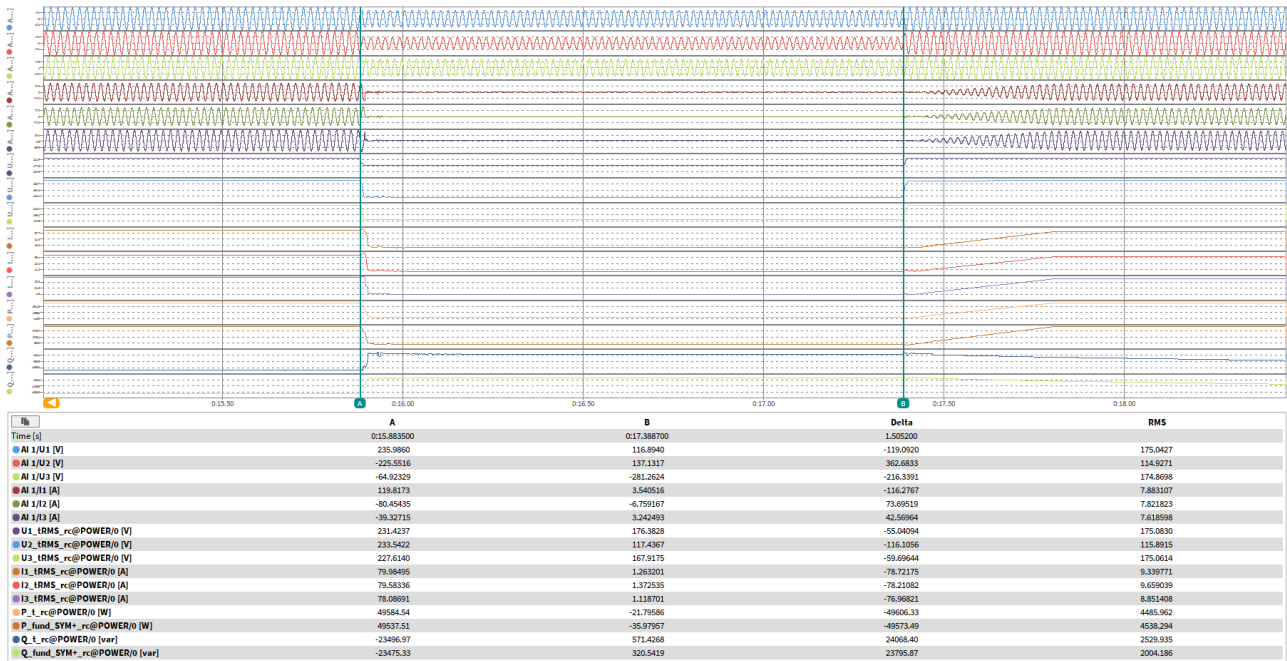
t1-10s to t1

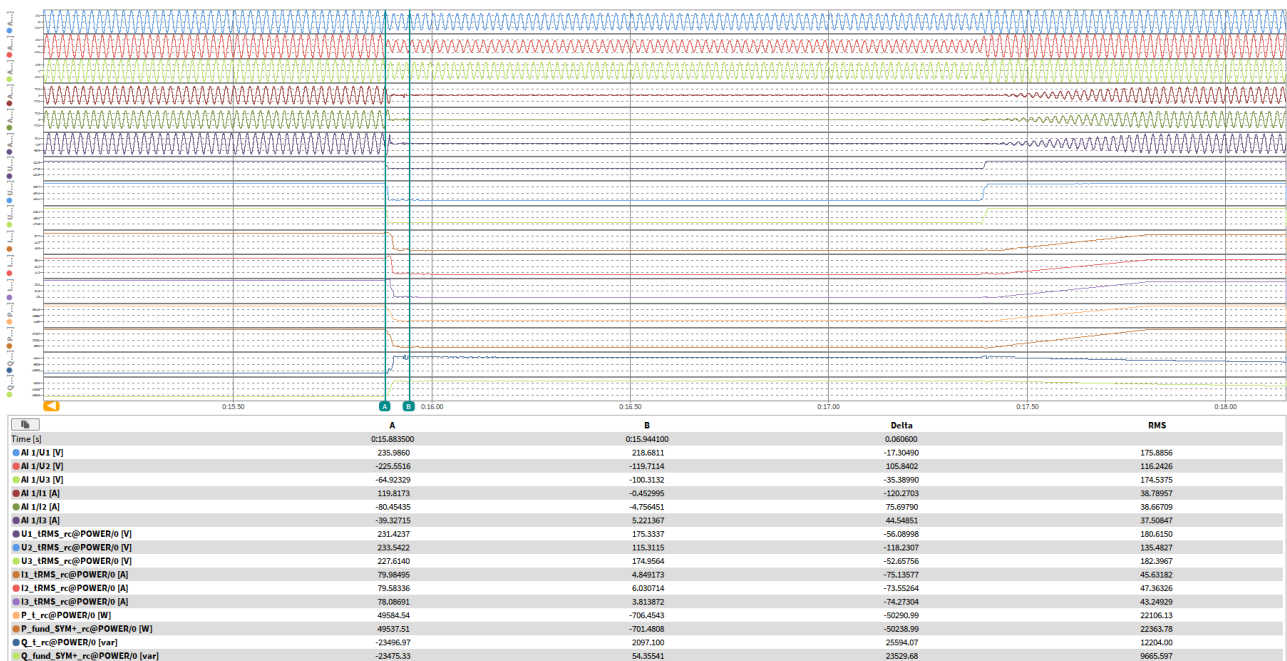

t1 to t2



t1+60ms

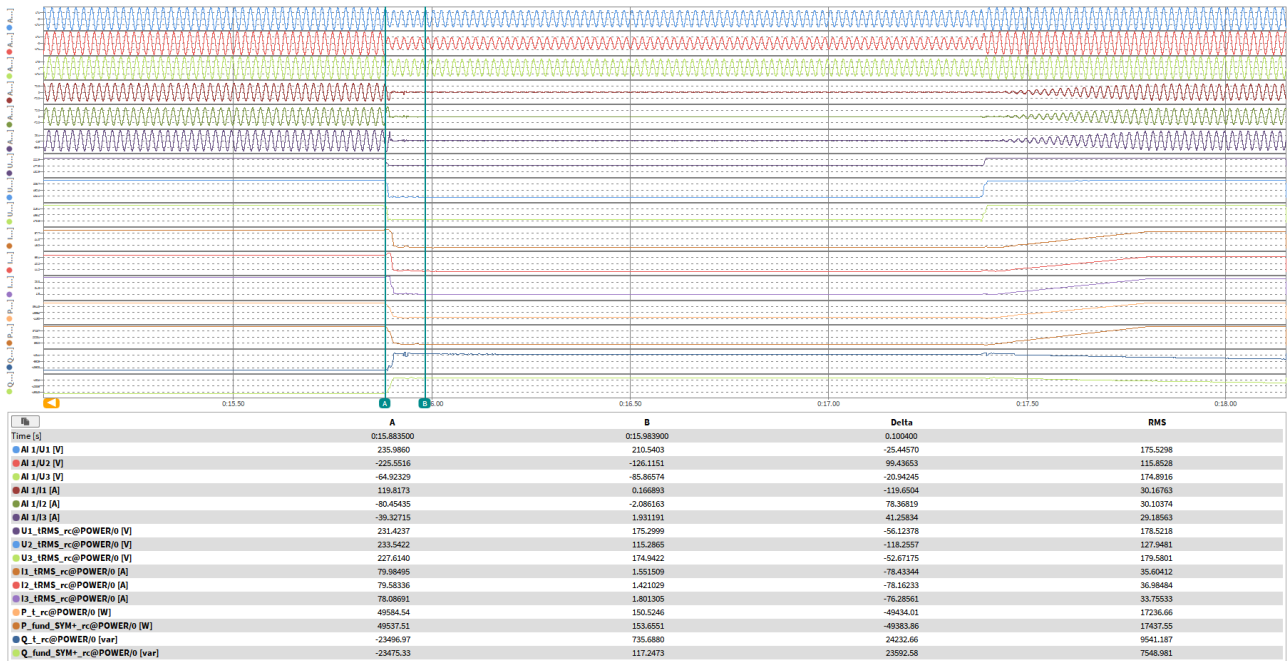

t1+100ms

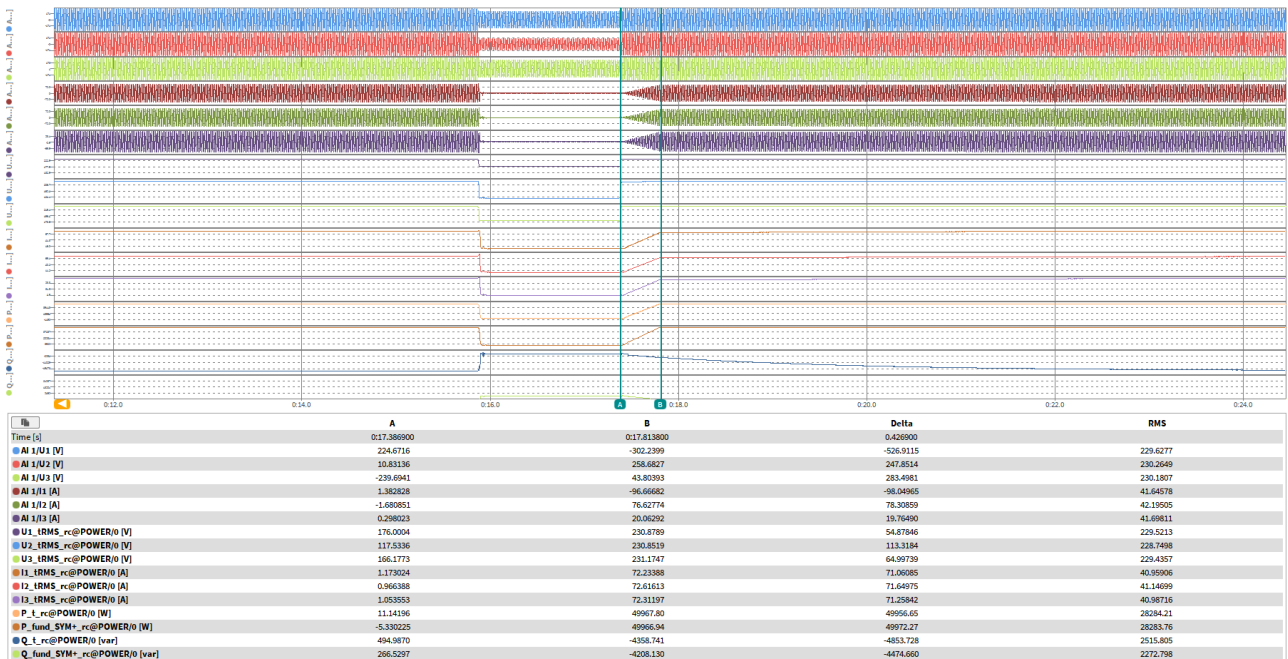

Active power rising time

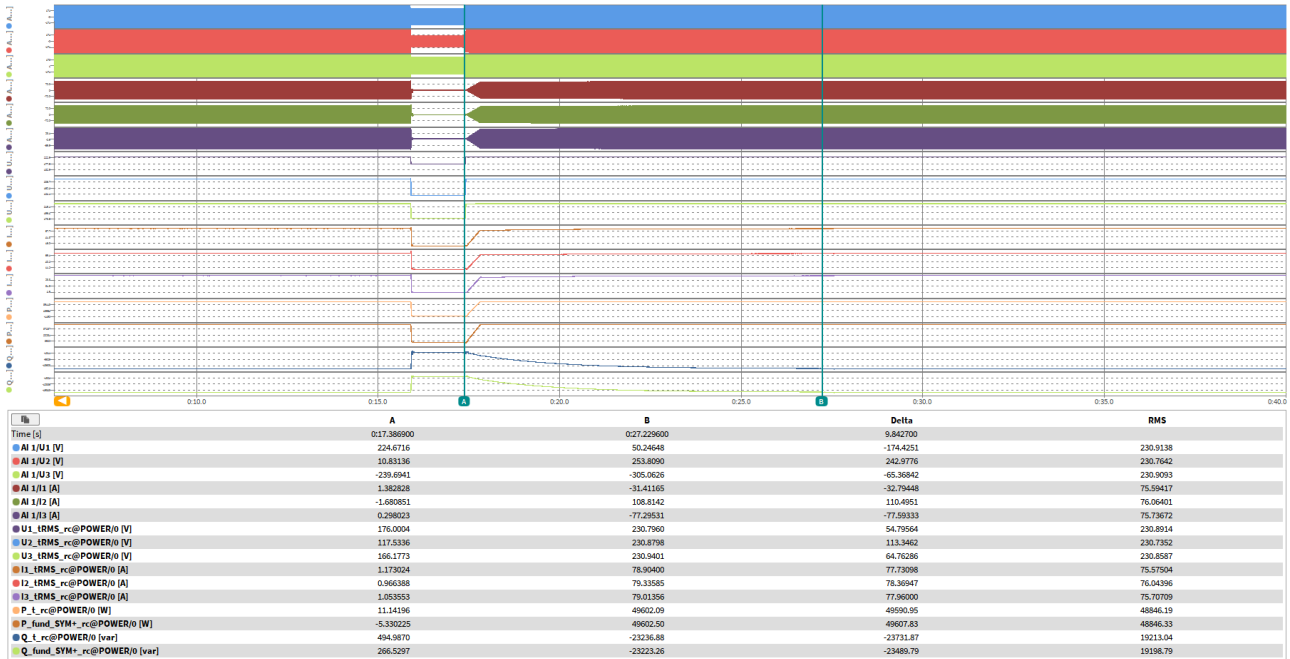

Reactive power rising time

Condition						Measurement
No.	Parameter	Phase ref.	Time ref.	unit		
General Info.	0	Test number	--	--	--	3.4
	1	Date	--	--	dd.mm.yyyy	08.06.2025
	2	Time (start of test)	--	--	hh:mm:ss.f	16:26:20
	3	Fault type (phase)	--	--		D1
	4	Setting voltage depth	Line to line	--	p.u.	0.50
	5	Setting dip duration		--		1500
	6	Point of fault entry	Total	--	ms	16199
	7	Point of fault clearance	Total	--	ms	17711
	8	Fault duration in empty load test	Total	--	ms	1601
	9	Voltage depth/height in empty load test	Total	t1+100ms to t2 and t1-10s to t1	p.u.	0.499
10	Pos.		p.u.		1.000	
Before dip <t1	11	Voltage	Line to neutral	t1-100s to t1	p.u.	1.000
	12	Current	Pos.	t1-500ms to t1-100ms	p.u.	0.555
	13	Active power	Total	t1-10s to t1	p.u.	0.500
	14		Pos.			0.500
	15	Reactive power	Total	t1-10s to t1	p.u.	-0.239
	16		Pos.			-0.239
17	Cos ϕ	--	t1-10s to t1	--	0.902	
During dip t1 to t2	18	Voltage	Line to neutral	t1+100ms to t2-20ms	p.u.	0.500
	19	Line current	Phase 1	t1+60ms	p.u.	0.049
	20		Phase 2			0.062
	21		Phase 3			0.047
	22	Line current	Phase 1	t1+100ms	p.u.	0.024
	23		Phase 2			0.028
	24		Phase 3			0.016
	25	Active power	Total	t1+100ms to t2-20ms	p.u.	0.006
26	Pos.		0.004			
After dip > t2	27	Voltage	Line to neutral	t2+3s to t2+10s	p.u.	1.000
	28	Active power	Total	t2+3s to t2+10s	p.u.	0.501
	29		Pos.			0.501
	39	Active power rising time	Pos.	--	s	0.229
	31	Reactive power	Total	t2+3s to t2+10s	p.u.	-0.238
	32		Pos.			-0.238
	33	Reactive power rising time	Pos.	--	s	9.979
	34	PGU does not disconnect from grid till 60s after fault	--	t2 to t2+60s	Yes / No	Yes

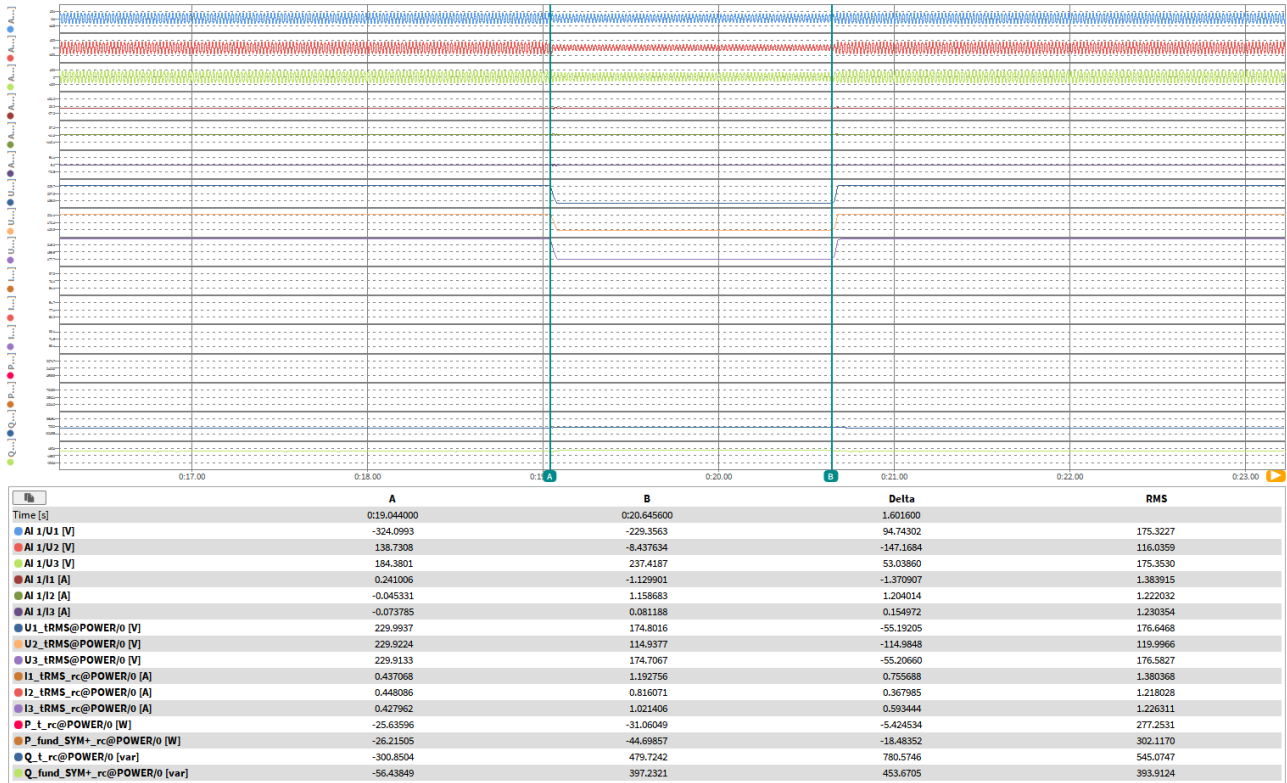
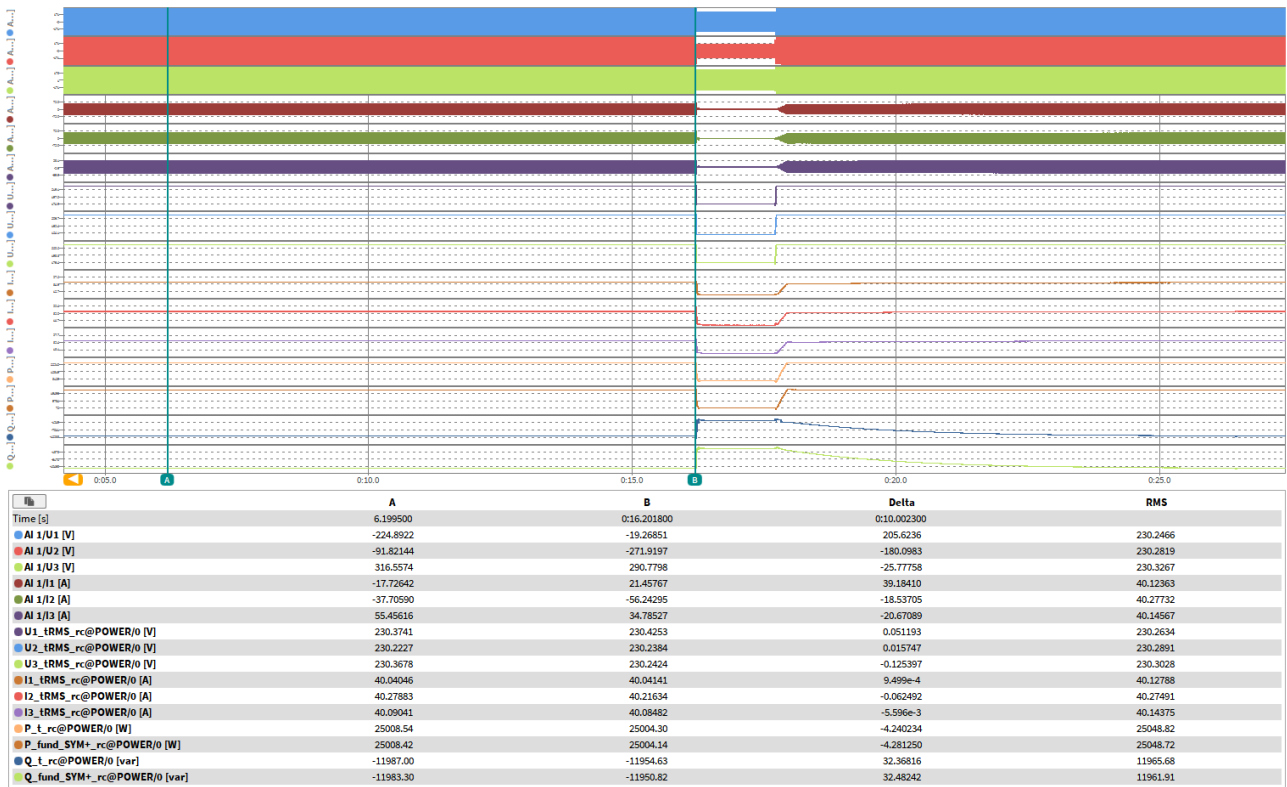
Test No. 3.4 idle test

Test No. 3.4 with PGU

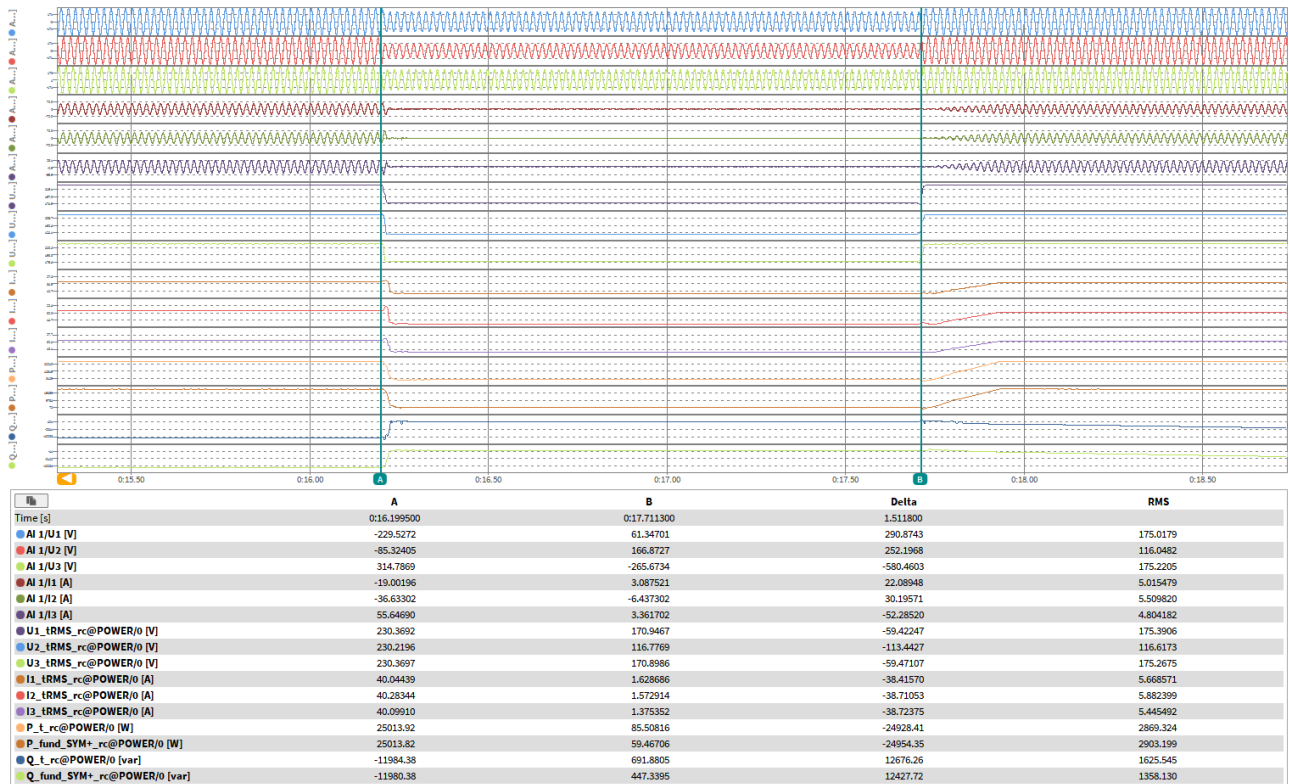
t1-10s to t1

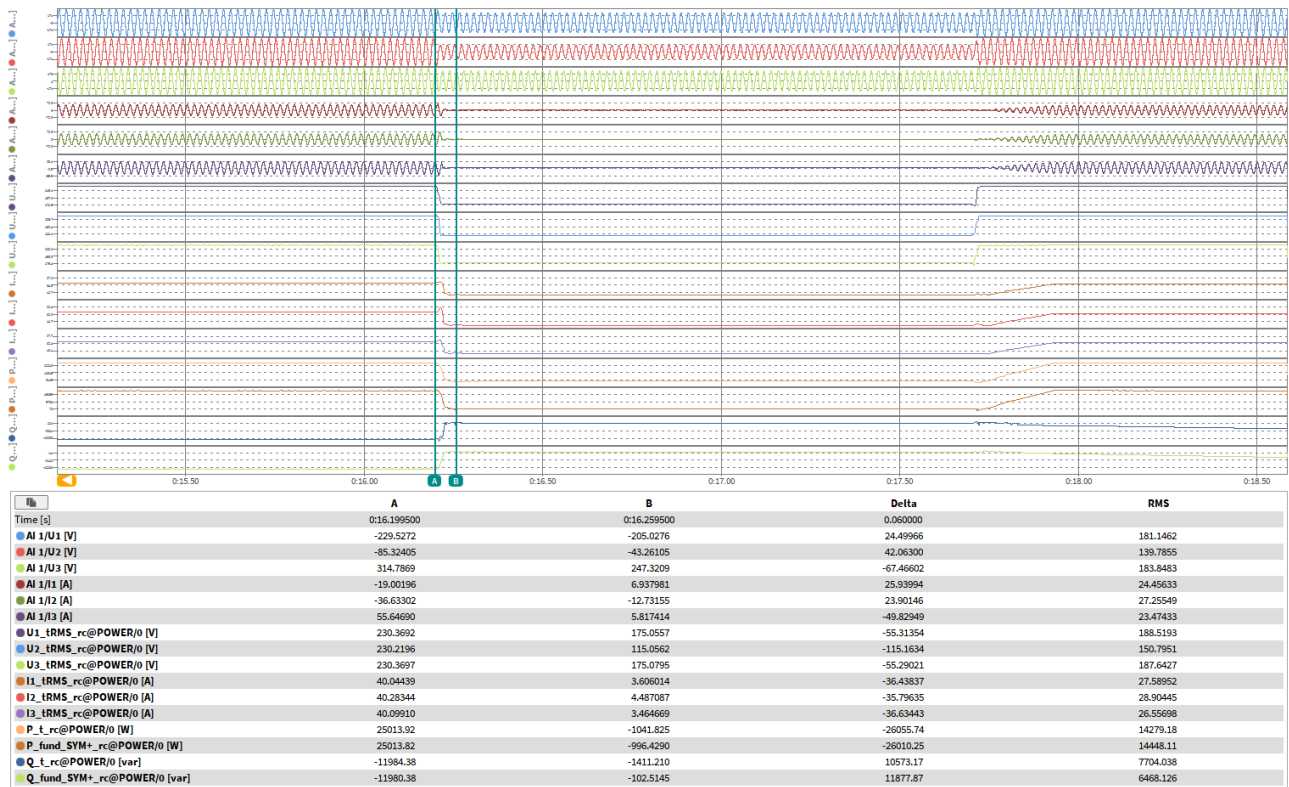

t1 to t2



t1+60ms

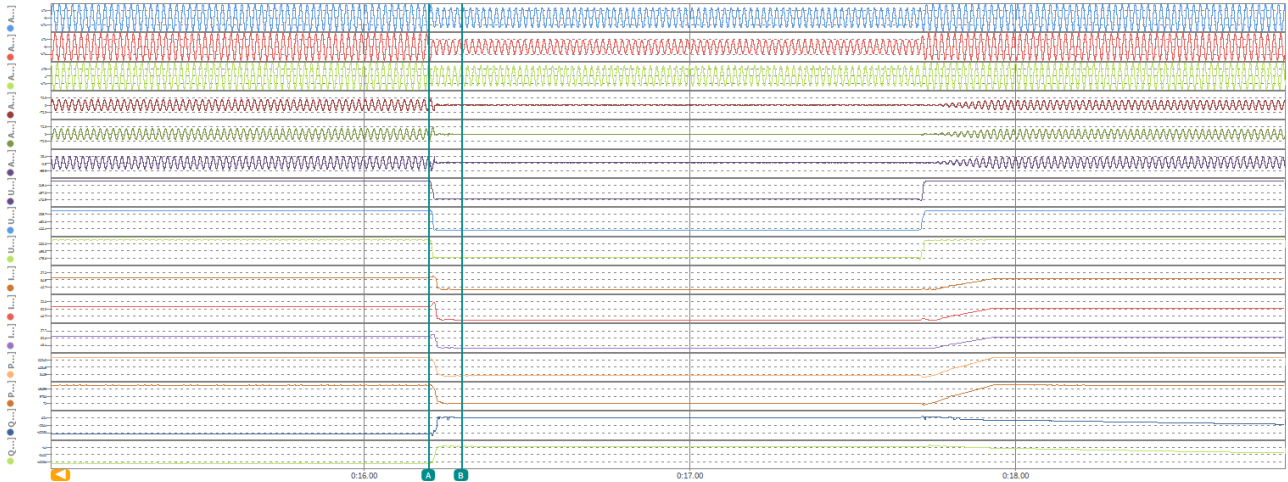

	A	B	Delta	RMS
Time [s]	0:16.199500	0:16.300100	0.100600	
AI 1/U1 [V]	-229.5272	-176.0049	53.52235	178.8041
AI 1/U2 [V]	-85.32405	-70.95957	14.36448	130.1819
AI 1/U3 [V]	314.7869	245.3993	-69.38768	180.8070
AI 1/I1 [A]	-19.00196	-0.524521	18.47744	18.92553
AI 1/I2 [A]	-36.63302	-0.774860	35.85816	21.11054
AI 1/I3 [A]	55.64690	1.311302	-54.33560	18.18344
U1_rms_rc@POWER/0 [V]	230.3692	175.1126	-55.25658	183.3018
U2_rms_rc@POWER/0 [V]	230.2196	115.0295	-115.1901	137.7768
U3_rms_rc@POWER/0 [V]	230.3697	174.9798	-55.38992	182.7255
I1_rms_rc@POWER/0 [A]	40.04439	1.734332	-38.31006	21.48834
I2_rms_rc@POWER/0 [A]	40.28344	2.071864	-38.21158	22.54634
I3_rms_rc@POWER/0 [A]	40.09910	1.159936	-38.93916	20.69255
P_t_rc@POWER/0 [W]	25013.92	-326.6772	-25340.60	11101.01
P_fund_SYM+_rc@POWER/0 [W]	25013.82	-411.5211	-25425.34	11232.07
Q_t_rc@POWER/0 [var]	-11984.38	669.5509	12653.93	6023.367
Q_fund_SYM+_rc@POWER/0 [var]	-11980.38	351.7712	12332.15	5038.535

t1+100ms

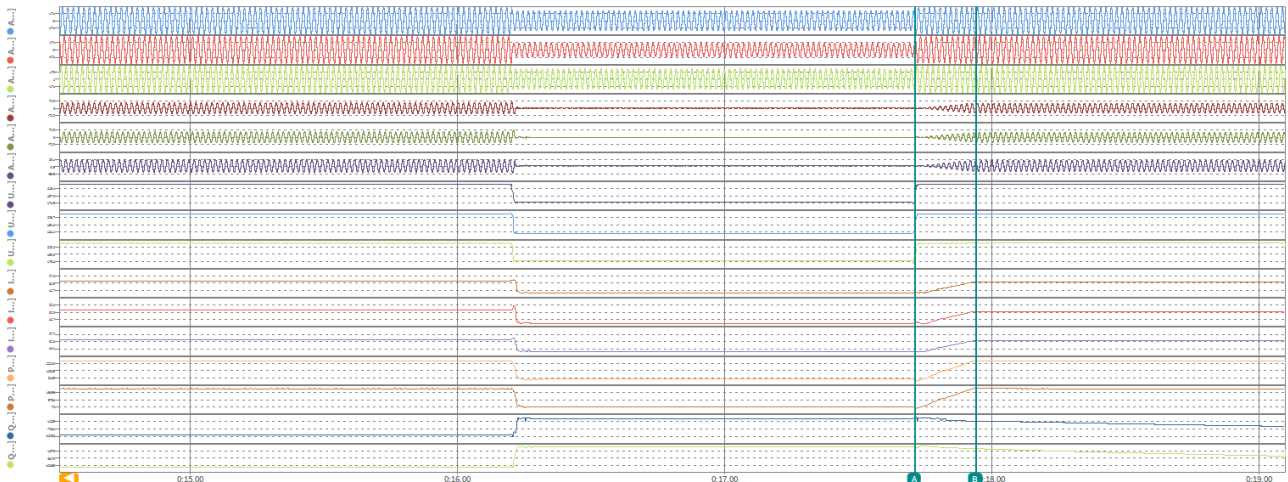

	A	B	Delta	RMS
Time [s]	0:17.711200	0:17.940300	0.229100	
AI 1/U1 [V]	69.64446	-166.1441	-235.7886	230.2589
AI 1/U2 [V]	160.8498	-159.8804	-320.7302	228.9198
AI 1/U3 [V]	-267.5715	325.4011	592.9726	229.3741
AI 1/I1 [A]	3.230572	-25.64192	-28.87249	21.49110
AI 1/I2 [A]	-6.258458	-26.05915	-19.80066	21.19478
AI 1/I3 [A]	3.039837	51.71299	48.67316	21.33809
U1_rms_rc@POWER/0 [V]	170.9467	230.4279	59.48119	228.4507
U2_rms_rc@POWER/0 [V]	116.7769	230.2871	113.5101	227.1596
U3_rms_rc@POWER/0 [V]	170.6986	230.4215	59.72289	228.5134
I1_rms_rc@POWER/0 [A]	1.629686	36.52918	34.90049	20.51158
I2_rms_rc@POWER/0 [A]	1.572914	36.71066	35.13775	20.59858
I3_rms_rc@POWER/0 [A]	1.375352	36.57262	35.19727	20.51563
P_t_rc@POWER/0 [W]	85.50816	25268.79	25183.28	14144.18
P_fund_SYM+_rc@POWER/0 [W]	59.46706	25268.55	25209.09	14144.11
Q_t_rc@POWER/0 [var]	691.8805	-1224.811	-1916.691	1053.037
Q_fund_SYM+_rc@POWER/0 [var]	447.3395	-907.9722	-1355.312	577.5092

Active power rising time



	A	B	Delta	RMS
Time [s]	0:17.711200	0:27.690300	9.979100	
AI 1/U1 [V]	69.64446	170.6510	101.0065	230.2700
AI 1/U2 [V]	160.8498	153.8527	-6.997109	230.2600
AI 1/U3 [V]	-267.5715	-325.8786	-58.30717	230.2865
AI 1/I1 [A]	3.230572	5.483628	2.253056	38.63106
AI 1/I2 [A]	-6.258488	46.37242	52.63090	38.75828
AI 1/I3 [A]	3.039837	-51.83220	-54.87204	38.64987
U1_IRMS_rc@POWER/0 [V]	170.9467	230.1599	59.21318	230.2284
U2_IRMS_rc@POWER/0 [V]	116.7769	230.3575	113.5806	230.2194
U3_IRMS_rc@POWER/0 [V]	170.8986	230.2306	59.33200	230.2673
I1_IRMS_rc@POWER/0 [A]	1.628686	40.22081	38.59213	38.61742
I2_IRMS_rc@POWER/0 [A]	1.572914	40.25962	38.68671	38.74836
I3_IRMS_rc@POWER/0 [A]	1.375352	40.16513	38.78978	38.63433
P_t_rc@POWER/0 [W]	85.50816	25080.90	24995.39	24856.65
P_fund_SYM+_rc@POWER/0 [W]	59.46706	25080.88	25021.41	24856.62
Q_t_rc@POWER/0 [var]	691.8805	-11941.42	-12633.30	9785.561
Q_fund_SYM+_rc@POWER/0 [var]	447.3395	-11930.84	-12378.18	9772.965

Reactive power rising time

Condition						Measurement
No.	Parameter	Phase ref.	Time ref.	unit		
General Info.	0	Test number	--	--	--	4.1
	1	Date	--	--	dd.mm.yyyy	15.05.2025
	2	Time (start of test)	--	--	hh:mm:ss.f	10:21:28
	3	Fault type (phase)	--	--		A
	4	Setting voltage depth	Line to line	--	p.u.	0.85
	5	Setting dip duration		--		60000
	6	Point of fault entry	Total	--	ms	17732
	7	Point of fault clearance	Total	--	ms	77735
	8	Fault duration in empty load test	Total	--	ms	61000
	9	Voltage depth/height in empty load test	Total	t1+100ms to t2 and t1-10s to t1	p.u.	0.849
10	Pos.		p.u.		1.000	
Before dip <t1	11	Voltage	Line to neutral	t1-100s to t1	p.u.	1.003
	12	Current	Pos.	t1-500ms to t1-100ms	p.u.	1.008
	13	Active power	Total	t1-10s to t1	p.u.	1.010
	14		Pos.			1.010
	15	Reactive power	Total	t1-10s to t1	p.u.	0.013
	16		Pos.			0.008
17	Cosφ	--	t1-10s to t1	--	0.000	
During dip t1 to t2	18	Voltage	Line to neutral	t1+100ms to t2-20ms	p.u.	0.854
	19	Line current	Phase 1	t1+60ms	p.u.	0.862
	20		Phase 2			0.865
	21		Phase 3			0.866
	22	Line current	Phase 1	t1+100ms	p.u.	0.843
	23		Phase 2			0.846
	24		Phase 3			0.845
	25	Active power	Total	t1+100ms to t2-20ms	p.u.	0.714
26	Pos.		0.712			
After dip > t2	27	Voltage	Line to neutral	t2+3s to t2+10s	p.u.	1.003
	28	Active power	Total	t2+3s to t2+10s	p.u.	1.009
	29		Pos.			1.006
	39	Active power rising time	Pos.	--	s	0.282
	31	Reactive power	Total	t2+3s to t2+10s	p.u.	0.012
	32		Pos.			0.006
	33	Reactive power rising time	Pos.	--	s	--
	34	PGU does not disconnect from grid till 60s after fault	--	t2 to t2+60s	Yes / No	Yes

Test No. 4.1 idle test

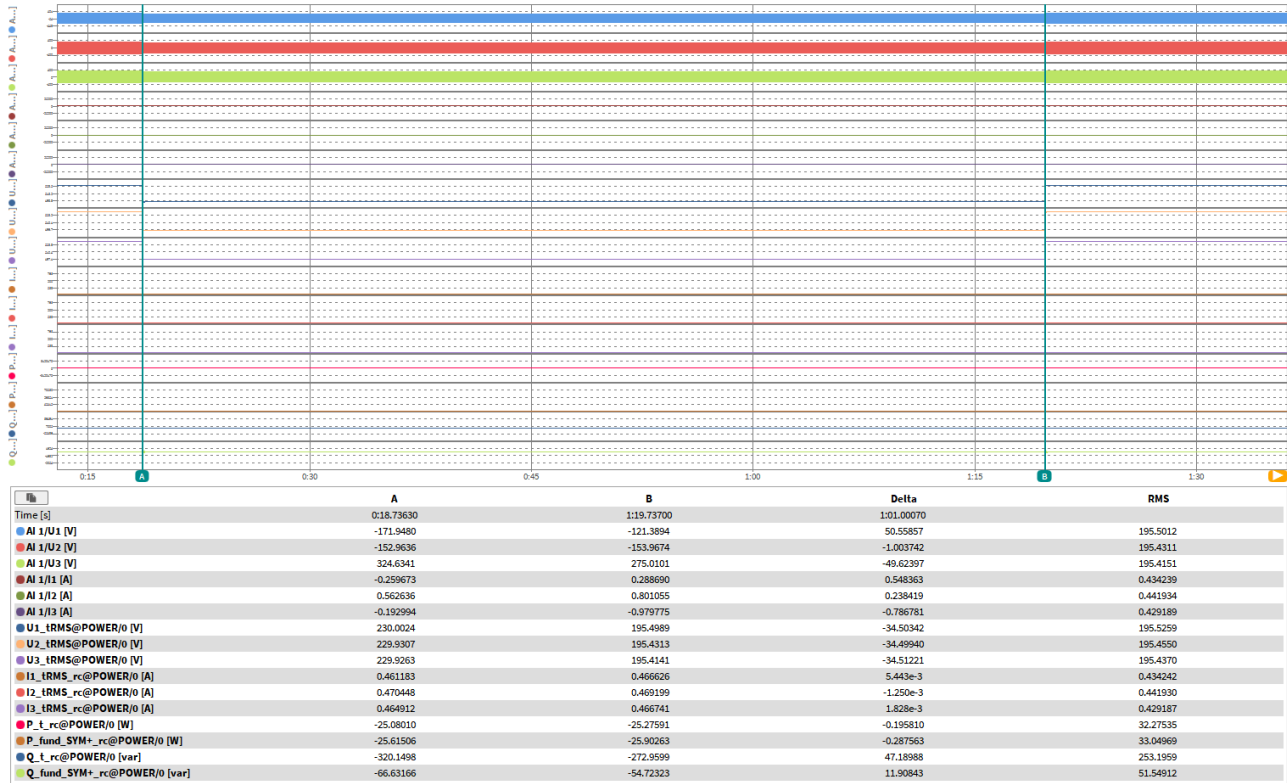

Test No. 4.1 with PGU

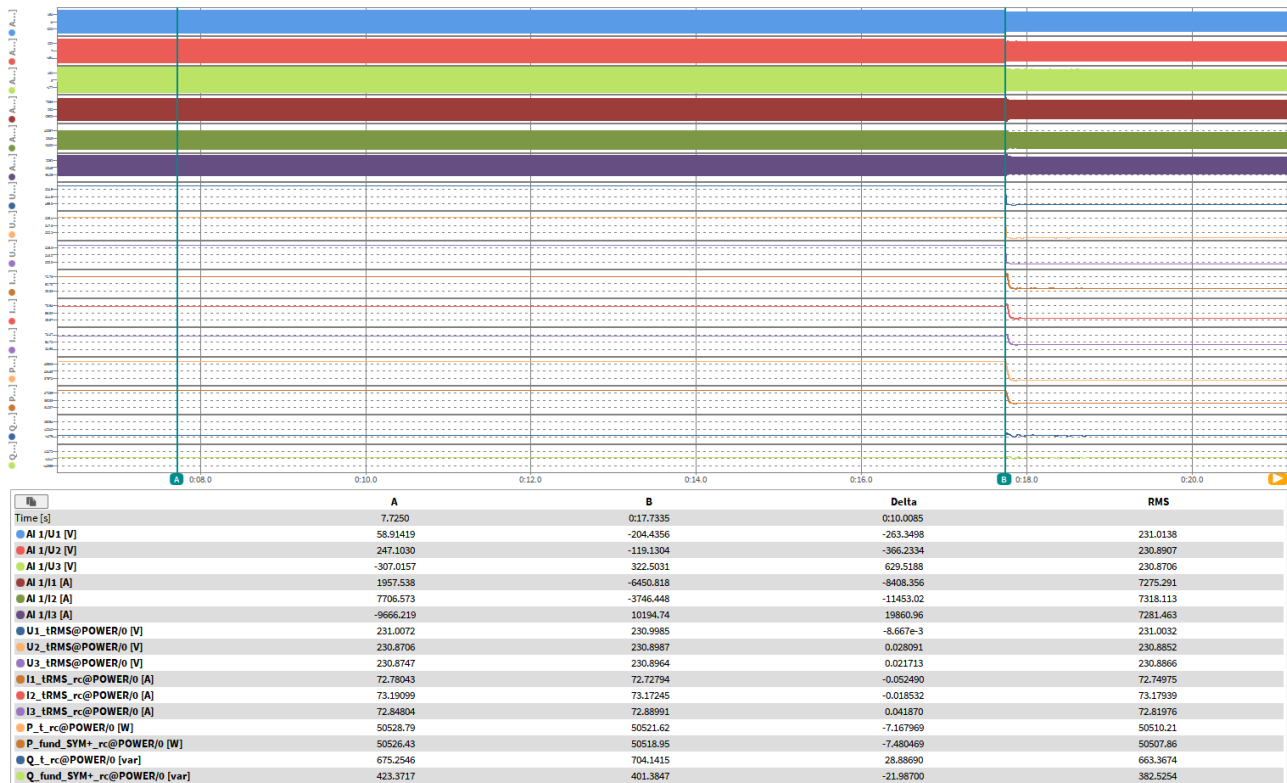

t1-10s to t1

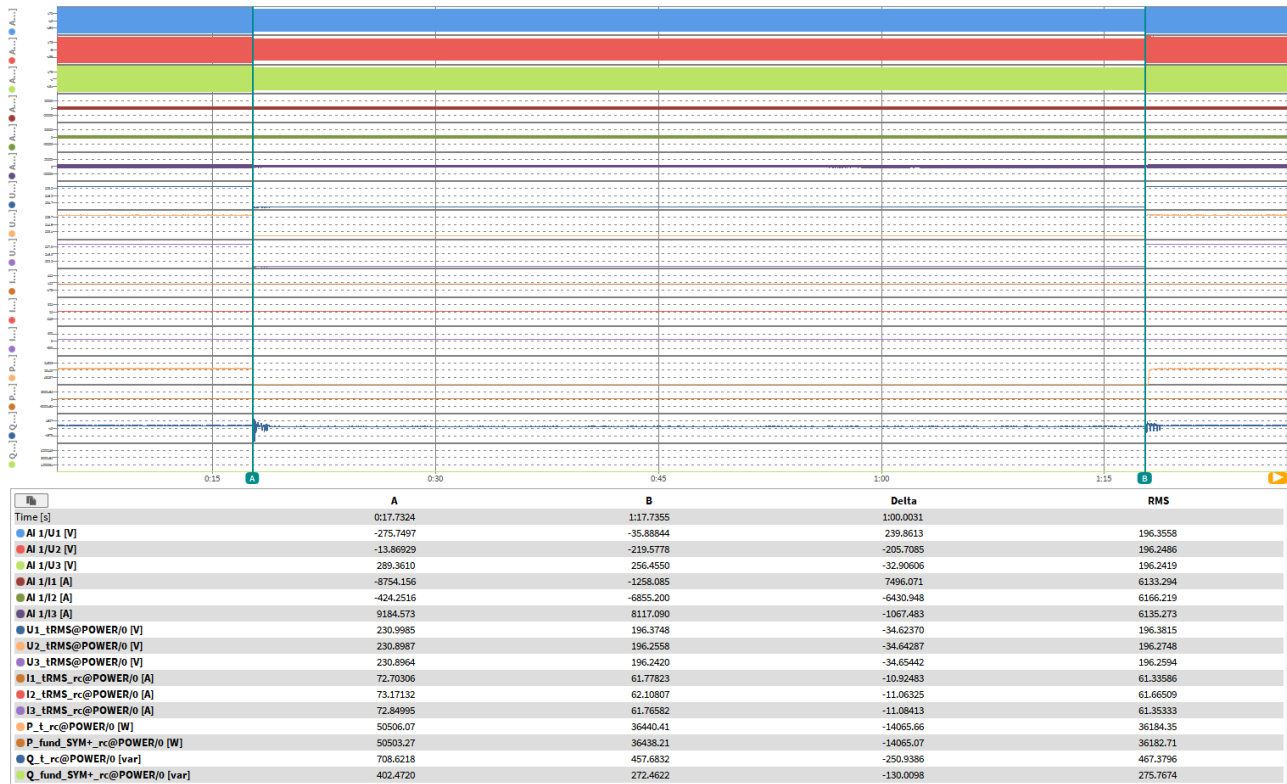

t1 to t2

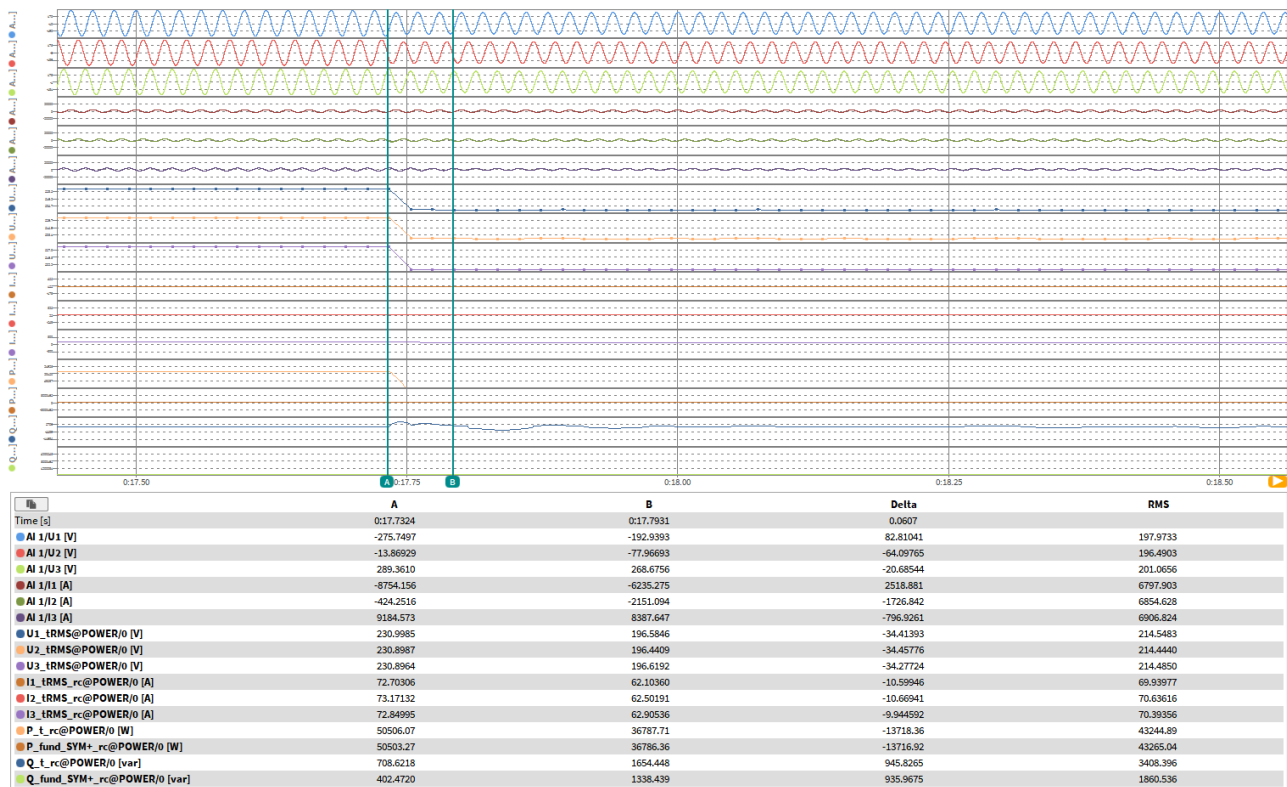

t1+60ms

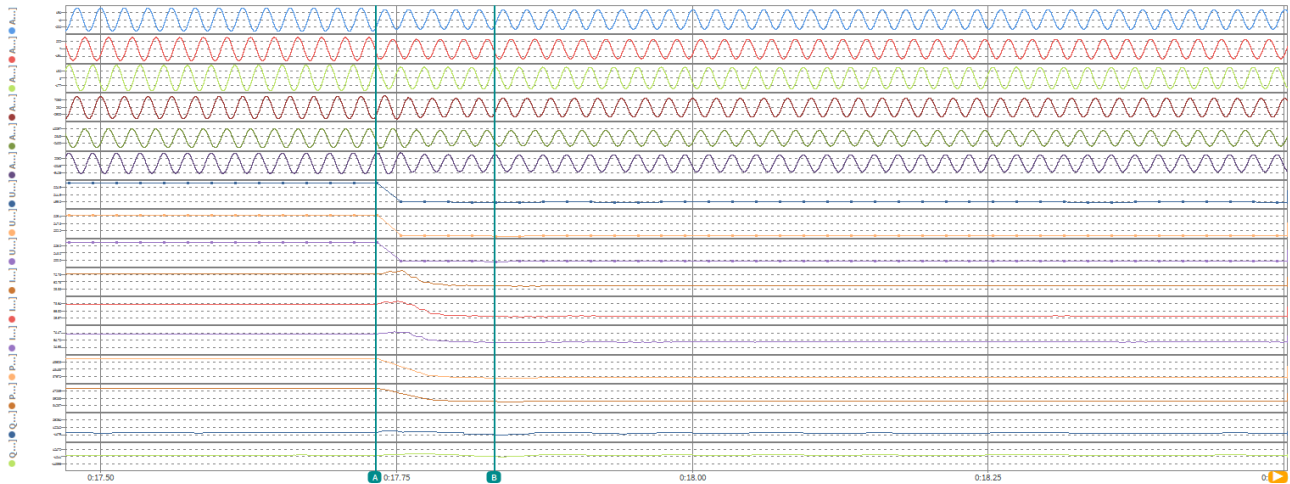

	A	B	Delta	RMS
Time [s]	0:17.7324	0:17.8331	0.1006	
AI 1/U1 [V]	-275.7497	-199.2366	76.51306	197.1106
AI 1/U2 [V]	-13.86929	-68.01892	-54.14963	196.2666
AI 1/U3 [V]	289.3610	265.9743	-23.38672	198.8856
AI 1/I1 [A]	-8754.156	-5633.280	3120.876	6529.505
AI 1/I2 [A]	-424.2516	-2610.774	-2386.522	6581.858
AI 1/I3 [A]	9184.573	8442.174	-742.3997	6612.292
U1_IRMS@POWER/0 [V]	230.9985	195.9605	-35.03806	208.6031
U2_IRMS@POWER/0 [V]	230.8987	195.8324	-35.06627	208.5037
U3_IRMS@POWER/0 [V]	230.8964	195.8016	-35.09480	208.5225
I1_IRMS@POWER/0 [A]	72.70306	60.97039	-11.73267	66.65641
I2_IRMS@POWER/0 [A]	73.17132	61.14502	-12.02629	67.29493
I3_IRMS@POWER/0 [A]	72.84995	61.09112	-11.75883	67.00219
P_t_rc@POWER/0 [W]	50506.07	35717.76	-14788.31	40580.20
P_fund_SYM+rc@POWER/0 [W]	50503.27	35716.55	-14786.73	40592.70
Q_t_rc@POWER/0 [var]	708.6218	-2745.720	-3454.342	2860.853
Q_fund_SYM+rc@POWER/0 [var]	402.4720	-2686.313	-3088.785	1724.548

t1+100ms

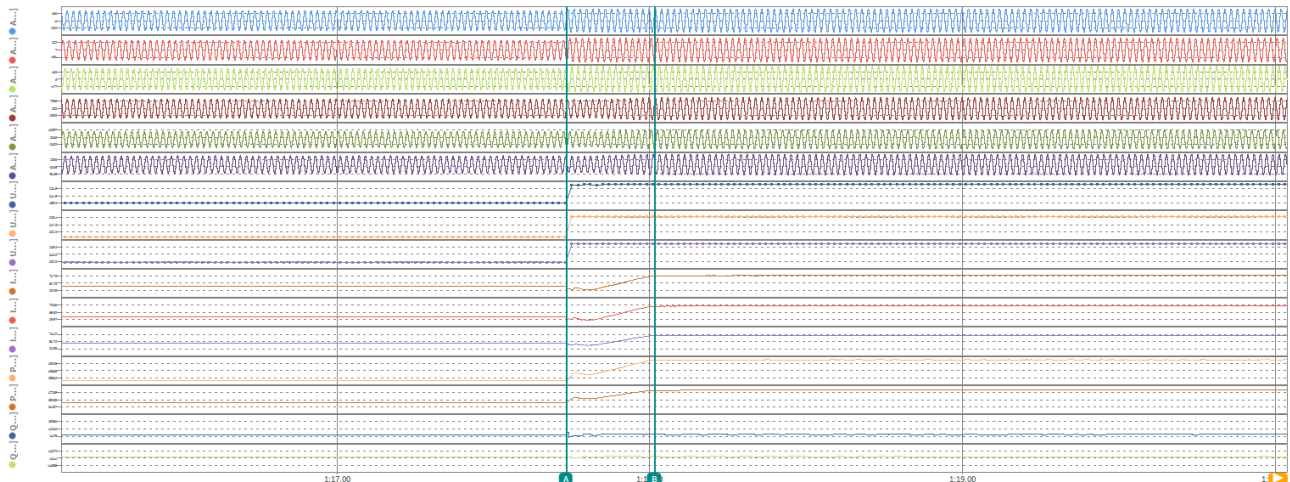

	A	B	Delta	RMS
Time [s]	1:17.7344	1:18.0169	0.2825	
AI 1/U1 [V]	-130.0497	98.09518	228.1449	229.9706
AI 1/U2 [V]	-147.1529	-318.2159	-171.0630	230.8464
AI 1/U3 [V]	277.0412	220.9730	-56.06819	231.0559
AI 1/I1 [A]	-4112.206	2852.335	6964.541	6410.001
AI 1/I2 [A]	-4654.215	-8807.072	-5152.858	6478.274
AI 1/I3 [A]	8765.851	6951.104	-1814.747	6463.695
U1_IRMS@POWER/0 [V]	196.3748	231.1063	34.73145	226.8964
U2_IRMS@POWER/0 [V]	196.2558	230.9970	34.74121	226.7754
U3_IRMS@POWER/0 [V]	196.2420	230.9933	34.75133	226.7660
I1_IRMS@POWER/0 [A]	61.77562	72.15371	10.37809	63.98466
I2_IRMS@POWER/0 [A]	62.11202	72.49198	10.37996	64.34907
I3_IRMS@POWER/0 [A]	61.76541	72.15842	10.39302	64.02301
P_t_rc@POWER/0 [W]	36440.48	50080.59	13640.11	44147.78
P_fund_SYM+rc@POWER/0 [W]	36438.50	50077.76	13639.26	44149.50
Q_t_rc@POWER/0 [var]	455.5371	867.1206	411.5835	1471.864
Q_fund_SYM+rc@POWER/0 [var]	270.3411	588.0217	317.6807	794.1714

Active power rising time

Condition						Measurement
No.	Parameter	Phase ref.	Time ref.	unit		
General Info.	0	Test number	--	--	--	4.2
	1	Date	--	--	dd.mm.yyyy	15.05.2025
	2	Time (start of test)	--	--	hh:mm:ss.f	10:24:19
	3	Fault type (phase)	--	--		A
	4	Setting voltage depth	Line to line	--	p.u.	0.85
	5	Setting dip duration		--		60000
	6	Point of fault entry	Total	--	ms	18390
	7	Point of fault clearance	Total	--	ms	78392
	8	Fault duration in empty load test	Total	--	ms	61000
	9	Voltage depth/height in empty load test	Total	t1+100ms to t2 and t1-10s to t1	p.u.	0.849
10	Pos.		p.u.		1.000	
Before dip <t1	11	Voltage	Line to neutral	t1-100s to t1	p.u.	1.001
	12	Current	Pos.	t1-500ms to t1-100ms	p.u.	0.499
	13	Active power	Total	t1-10s to t1	p.u.	0.499
	14		Pos.			0.499
	15	Reactive power	Total	t1-10s to t1	p.u.	0.008
	16		Pos.			0.002
17	Cos ϕ	--	t1-10s to t1	--	0.999	
During dip t1 to t2	18	Voltage	Line to neutral	t1+100ms to t2-20ms	p.u.	0.853
	19	Line current	Phase 1	t1+60ms	p.u.	0.591
	20		Phase 2			0.583
	21		Phase 3			0.594
	22	Line current	Phase 1	t1+100ms	p.u.	0.595
	23		Phase 2			0.600
	24		Phase 3			0.598
	25	Active power	Total	t1+100ms to t2-20ms	p.u.	0.506
26	Pos.		0.505			
After dip > t2	27	Voltage	Line to neutral	t2+3s to t2+10s	p.u.	1.001
	28	Active power	Total	t2+3s to t2+10s	p.u.	0.499
	29		Pos.			0.499
	39	Active power rising time	Pos.	--	s	0.102
	31	Reactive power	Total	t2+3s to t2+10s	p.u.	0.009
	32		Pos.			0.002
	33	Reactive power rising time	Pos.	--	s	--
	34	PGU does not disconnect from grid till 60s after fault	--	t2 to t2+60s	Yes / No	Yes

Test No. 4.2 idle test

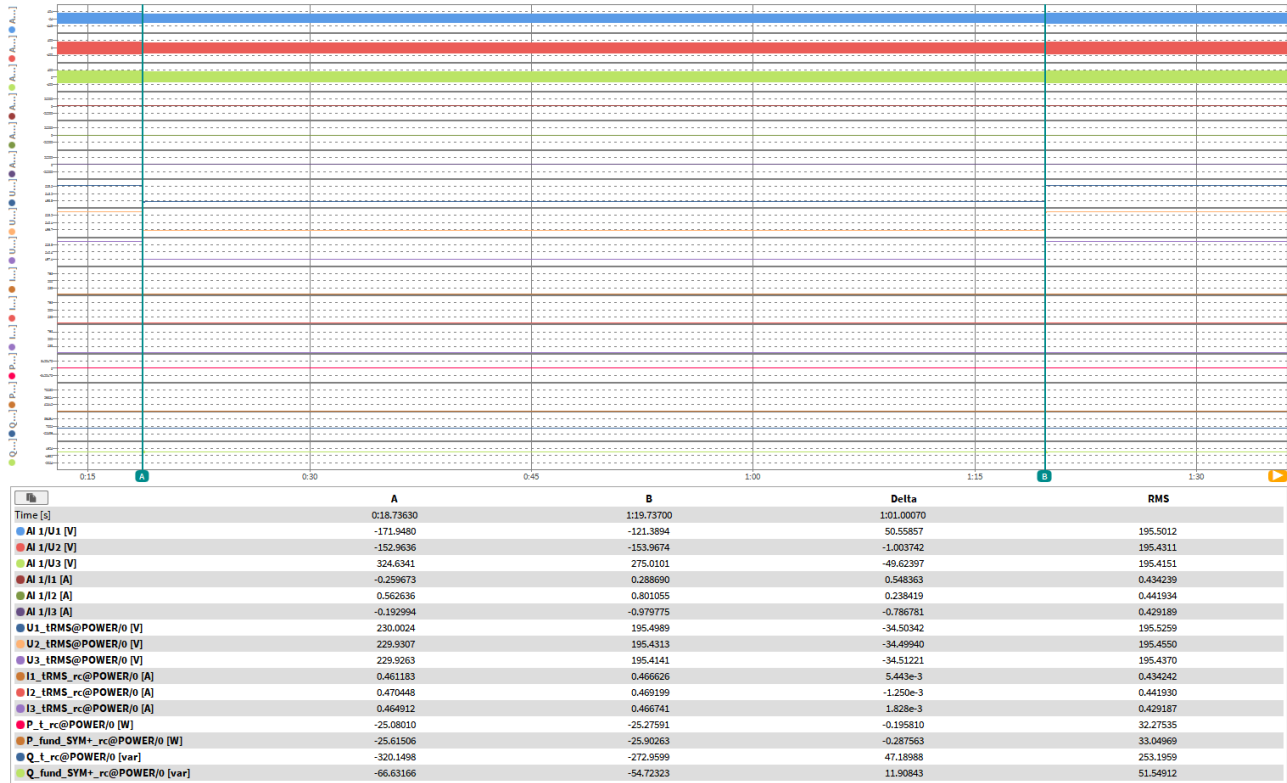

Test No. 4.2 with PGU

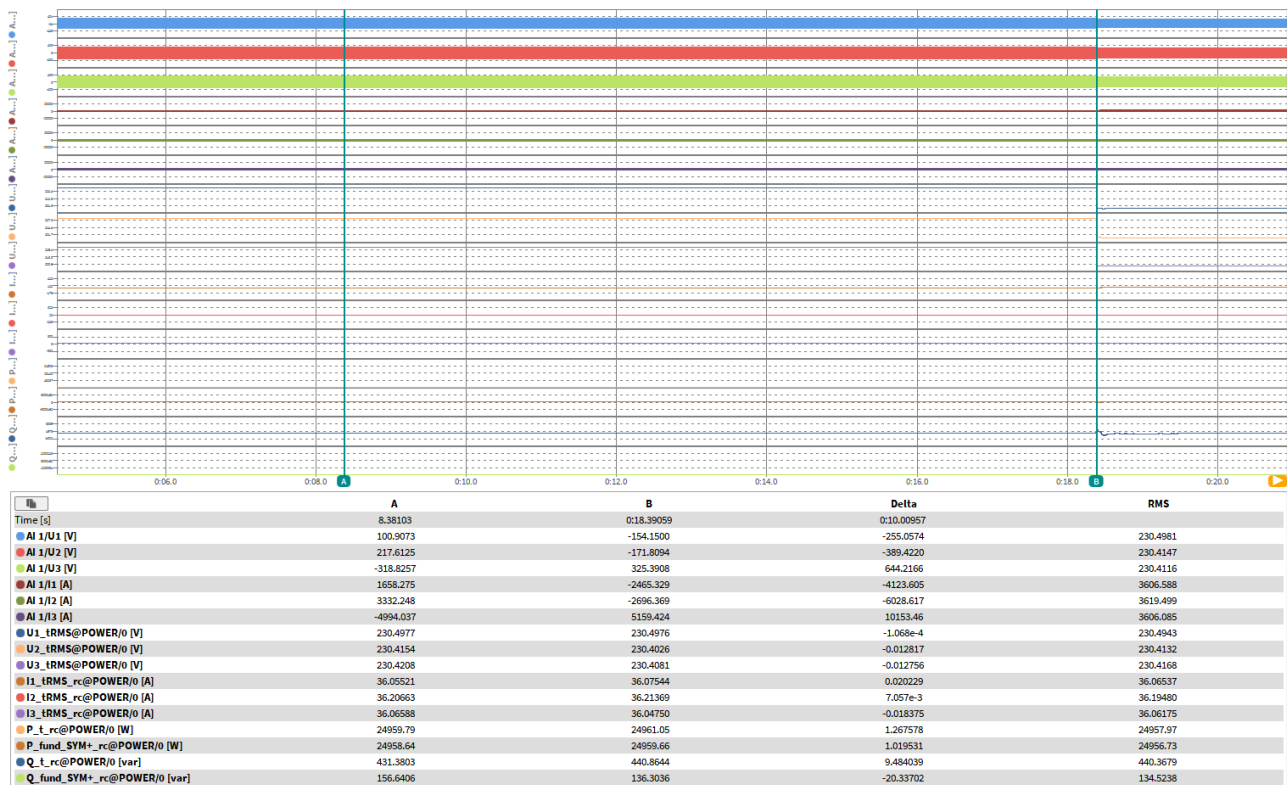

t1-10s to t1

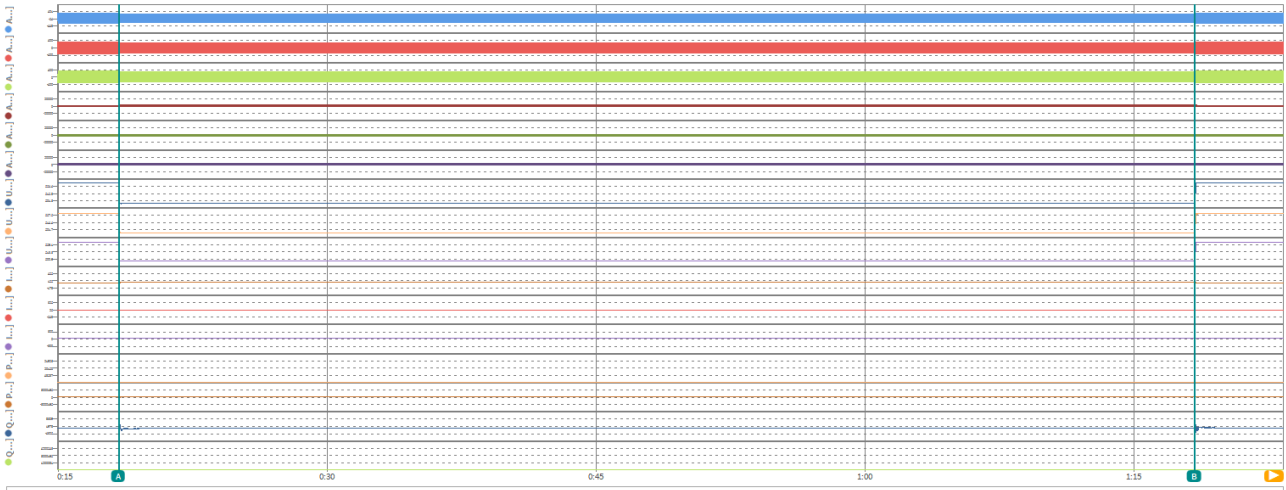

	A	B	Delta	RMS
Time [s]	0:18.39033	1:18.39219	1:00.00185	
AI 1/U1 [V]	-172.8990	-24.68825	148.2108	196.0590
AI 1/U2 [V]	-155.2036	-225.8594	-70.65583	196.0060
AI 1/U3 [V]	327.3597	251.7803	-75.57941	195.9926
AI 1/I1 [A]	-2731.452	-550.2198	2181.232	4241.504
AI 1/I2 [A]	-2478.037	-4897.569	-2419.531	4259.268
AI 1/I3 [A]	5209.194	5450.175	240.9816	4241.084
U1_IRMS@POWER/0 [V]	230.4976	196.1140	-34.38364	196.1256
U2_IRMS@POWER/0 [V]	230.4026	196.0021	-34.40056	196.0303
U3_IRMS@POWER/0 [V]	230.4081	195.9863	-34.42183	196.0133
I1_IRMS@POWER/0 [A]	36.07544	42.39169	6.316254	42.41423
I2_IRMS_rc@POWER/0 [A]	36.21369	42.58241	6.368713	42.59186
I3_IRMS_rc@POWER/0 [A]	36.04750	42.39136	6.343857	42.40927
P_t_rc@POWER/0 [W]	24961.05	24964.54	3.488281	24975.14
P_fund_SYM+rc@POWER/0 [W]	24959.66	24962.74	3.085938	24973.69
Q_t_rc@POWER/0 [var]	440.8644	374.0618	-66.80258	390.8896
Q_fund_SYM+rc@POWER/0 [var]	136.3036	120.4278	-15.87581	165.0992

t1 to t2



	A	B	Delta	RMS
Time [s]	0:18.39033	0:18.45053	0:06019	
AI 1/U1 [V]	-172.8990	-129.1475	43.75148	196.2450
AI 1/U2 [V]	-155.2036	-147.5868	7.616759	197.0466
AI 1/U3 [V]	327.3597	276.5131	-50.84658	198.5177
AI 1/I1 [A]	-2731.452	-2826.486	-95.03365	4028.071
AI 1/I2 [A]	-2478.037	-3346.238	-868.2013	4005.423
AI 1/I3 [A]	5209.194	6172.584	963.3899	4030.025
U1_IRMS@POWER/0 [V]	230.4976	196.4521	-34.04558	214.0960
U2_IRMS@POWER/0 [V]	230.4026	196.3220	-34.08064	214.0575
U3_IRMS@POWER/0 [V]	230.4081	196.3750	-34.03313	214.0775
I1_IRMS_rc@POWER/0 [A]	36.07544	42.70203	6.626595	38.90598
I2_IRMS_rc@POWER/0 [A]	36.21369	42.54319	6.329502	39.01254
I3_IRMS_rc@POWER/0 [A]	36.04750	42.74345	6.695946	38.93221
P_t_rc@POWER/0 [W]	24961.05	25087.18	126.1230	23665.81
P_fund_SYM+rc@POWER/0 [W]	24959.66	25086.02	126.3613	23689.19
Q_t_rc@POWER/0 [var]	440.8644	776.0998	335.2354	2125.510
Q_fund_SYM+rc@POWER/0 [var]	136.3036	195.1396	58.83603	1069.639

t1+60ms

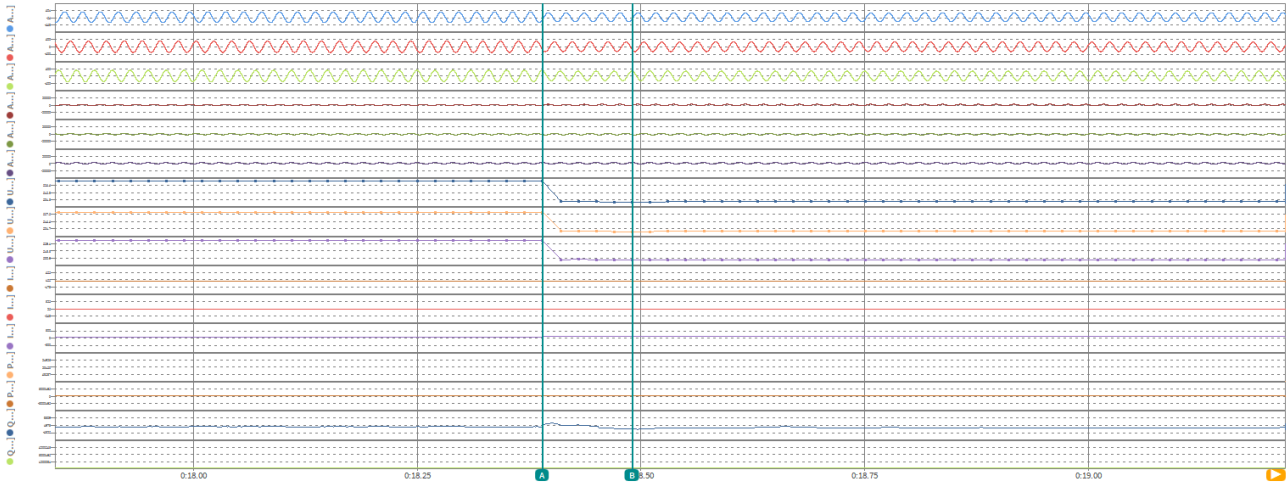

	A	B	Delta	RMS
Time [s]	0:18.39033	0:18.49056	0.10023	
AI 1/U1 [V]	-172.8990	-129.2346	43.66446	196.0745
AI 1/U2 [V]	-155.2036	-147.0151	8.188487	196.5249
AI 1/U3 [V]	327.3597	276.1202	-51.23949	197.5925
AI 1/I1 [A]	-2731.452	-2506.969	224.4830	4141.015
AI 1/I2 [A]	-2478.037	-3613.196	-1135.159	4139.305
AI 1/I3 [A]	5209.194	6119.392	910.1987	4150.977
U1_IRMS@POWER/0 [V]	230.4976	195.8784	-34.61925	208.2409
U2_IRMS@POWER/0 [V]	230.4026	195.7939	-34.60869	208.1918
U3_IRMS@POWER/0 [V]	230.4081	195.7816	-34.62650	208.1995
I1_IRMS@POWER/0 [A]	36.07544	43.10908	7.033642	40.63500
I2_IRMS@POWER/0 [A]	36.21369	43.26755	7.053860	40.78807
I3_IRMS@POWER/0 [A]	36.04750	43.21259	7.165089	40.64857
P_t_rc@POWER/0 [W]	24961.05	25300.41	339.3594	24353.48
P_fund_SYM+_rc@POWER/0 [W]	24959.66	25299.65	339.9902	24366.84
Q_t_rc@POWER/0 [var]	440.8644	-1711.562	-2152.426	1802.411
Q_fund_SYM+_rc@POWER/0 [var]	136.3036	-1669.120	-1805.424	1051.310

t1+100ms

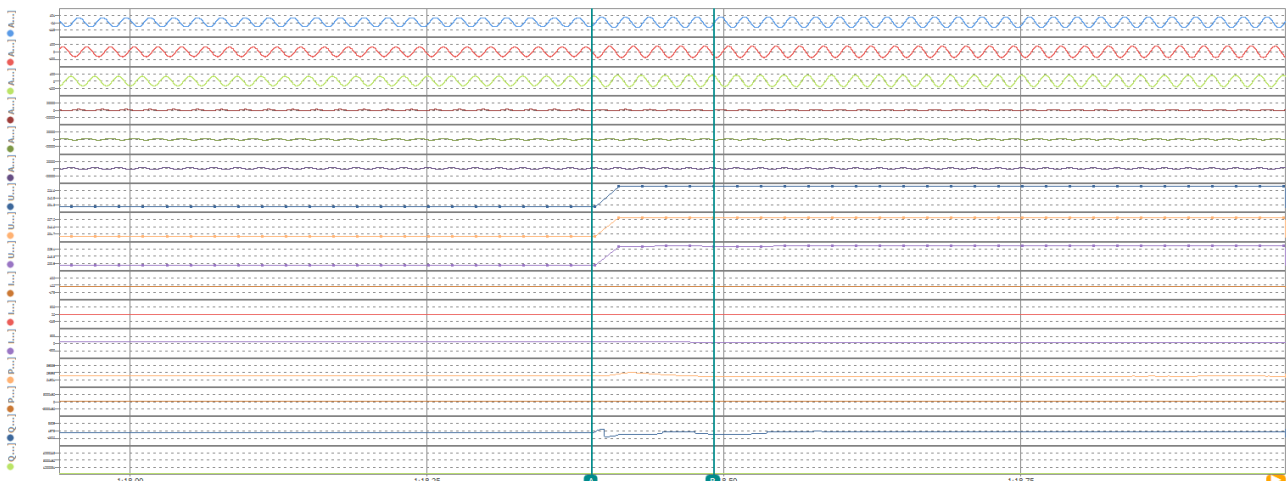

	A	B	Delta	RMS
Time [s]	1:18.38838	1:18.49116	0.10278	
AI 1/U1 [V]	-266.5568	-133.0743	133.4825	229.7243
AI 1/U2 [V]	67.65175	-189.3909	-257.0427	227.0036
AI 1/U3 [V]	198.2236	322.5632	124.3396	230.2106
AI 1/I1 [A]	-5736.492	-1630.566	4105.926	3830.753
AI 1/I2 [A]	1582.756	-3213.463	-4796.219	3808.204
AI 1/I3 [A]	4154.954	4644.115	689.1609	3879.652
U1_IRMS@POWER/0 [V]	196.1140	230.4697	34.35571	219.5465
U2_IRMS@POWER/0 [V]	196.0021	230.4075	34.40543	219.4033
U3_IRMS@POWER/0 [V]	195.9863	230.4033	34.41702	219.3901
I1_IRMS@POWER/0 [A]	42.41640	35.43206	-6.984337	39.06949
I2_IRMS@POWER/0 [A]	42.57911	35.65930	-6.919811	39.23882
I3_IRMS@POWER/0 [A]	42.40746	35.71765	-6.689804	39.06346
P_t_rc@POWER/0 [W]	24972.31	24549.66	-422.6426	26348.27
P_fund_SYM+_rc@POWER/0 [W]	24970.70	24548.37	-422.3262	26359.59
Q_t_rc@POWER/0 [var]	377.2363	-1310.672	-1687.969	1714.418
Q_fund_SYM+_rc@POWER/0 [var]	129.5652	-1073.762	-1203.327	799.2132

Active power rising time

Condition						Measurement
No.	Parameter	Phase ref.	Time ref.	unit		
General Info.	0	Test number	--	--	--	4.3
	1	Date	--	--	dd.mm.yyyy	15.05.2025
	2	Time (start of test)	--	--	hh:mm:ss.f	10:24:19
	3	Fault type (phase)	--	--		D1
	4	Setting voltage depth	Line to line	--	p.u.	0.85
	5	Setting dip duration		--		60000
	6	Point of fault entry	Total	--	ms	22131
	7	Point of fault clearance	Total	--	ms	83131
	8	Fault duration in empty load test	Total	--	ms	60005
	9	Voltage depth/height in empty load test	Total	t1+100ms to t2 and t1-10s to t1	p.u.	0.850
10	Pos.		p.u.		1.000	
Before dip <t1	11	Voltage	Line to neutral	t1-100s to t1	p.u.	1.003
	12	Current	Pos.	t1-500ms to t1-100ms	p.u.	1.008
	13	Active power	Total	t1-10s to t1	p.u.	1.010
	14		Pos.			1.010
	15	Reactive power	Total	t1-10s to t1	p.u.	0.007
	16		Pos.			0.001
17	Cos ϕ	--	t1-10s to t1	--	0.999	
During dip t1 to t2	18	Voltage	Line to neutral	t1+100ms to t2-20ms	p.u.	0.853
	19	Line current	Phase 1	t1+60ms	p.u.	1.088
	20		Phase 2			1.090
	21		Phase 3			1.086
	22	Line current	Phase 1	t1+100ms	p.u.	1.087
	23		Phase 2			1.089
	24		Phase 3			1.090
	25	Active power	Total	t1+100ms to t2-20ms	p.u.	0.984
26	Pos.		0.983			
After dip > t2	27	Voltage	Line to neutral	t2+3s to t2+10s	p.u.	1.003
	28	Active power	Total	t2+3s to t2+10s	p.u.	1.009
	29		Pos.			1.008
	39	Active power rising time	Pos.	--	s	0.244
	31	Reactive power	Total	t2+3s to t2+10s	p.u.	0.008
	32		Pos.			0.001
	33	Reactive power rising time	Pos.	--	s	--
	34	PGU does not disconnect from grid till 60s after fault	--	t2 to t2+60s	Yes / No	Yes

Test No. 4.3 idle test

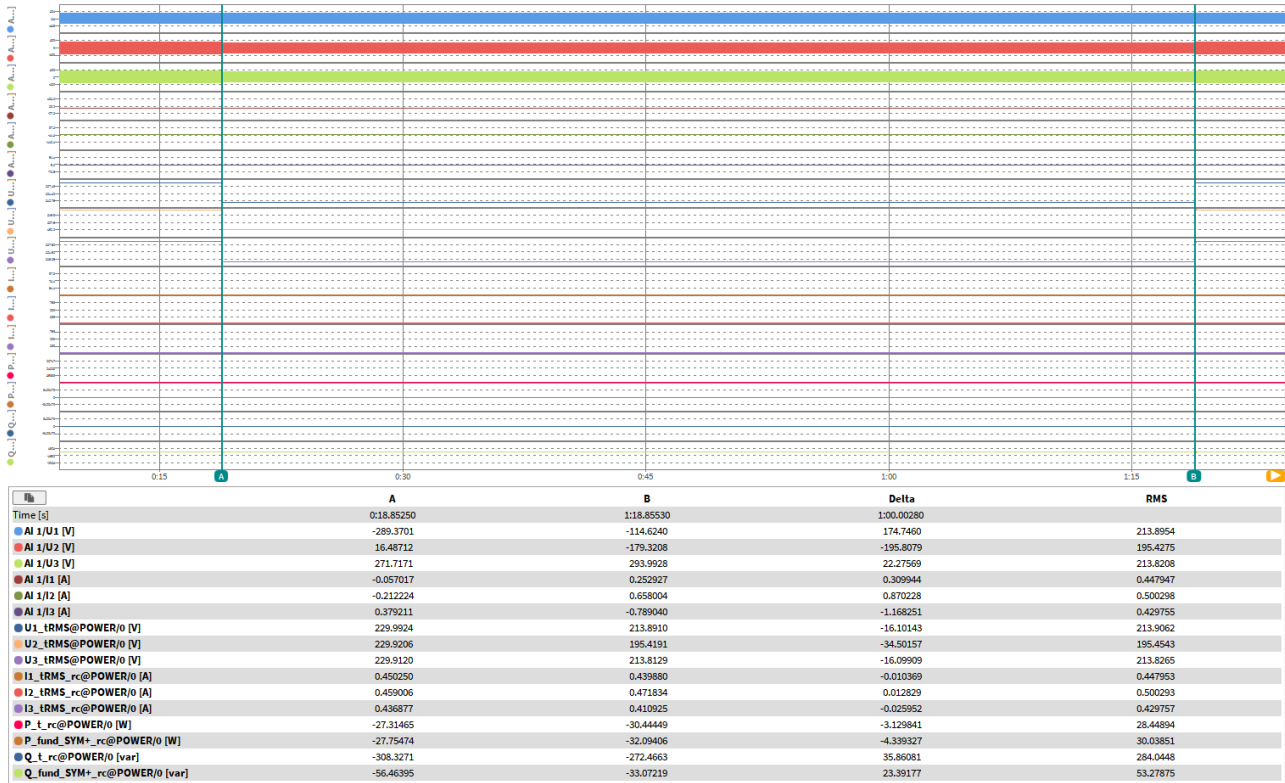

Test No. 4.3 with PGU

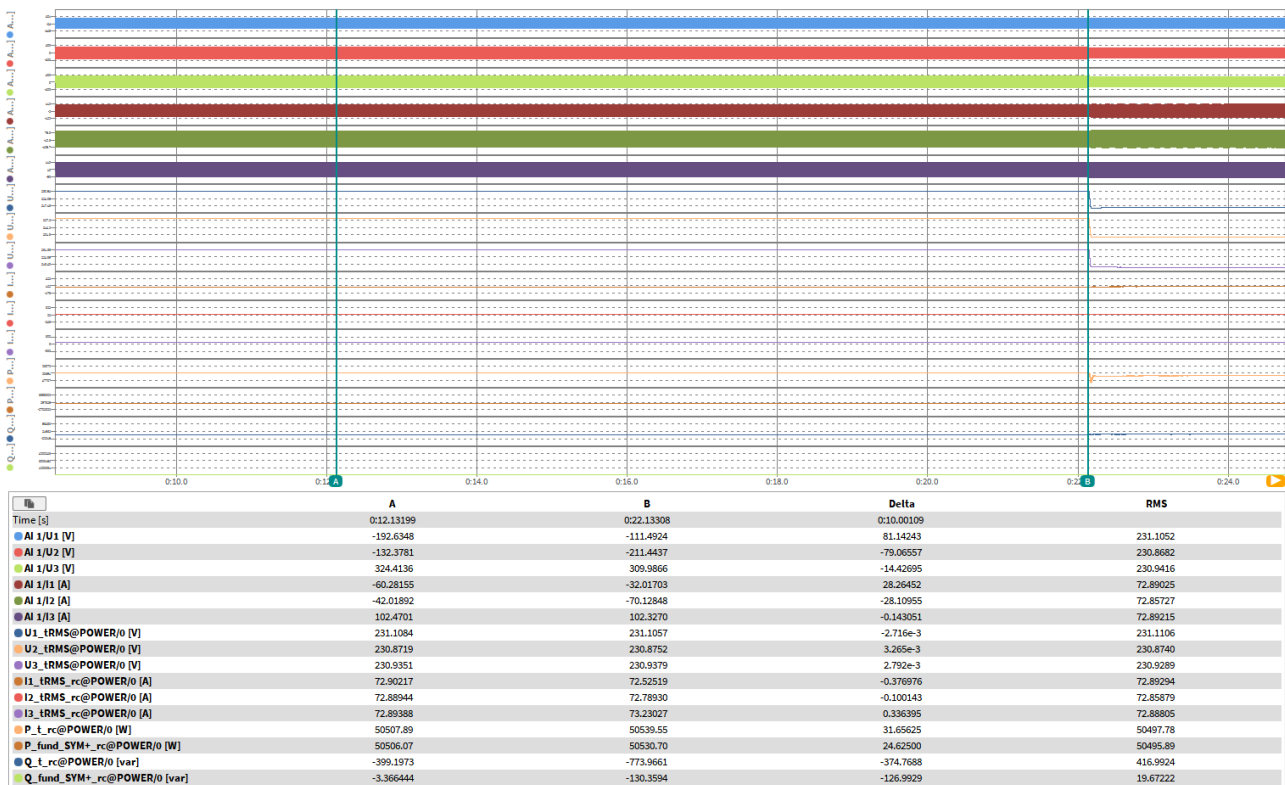

t1-10s to t1



	A	B	Delta	RMS
Time [s]	0:22.13194	1:23.13158	1:00.99964	
AI 1/U1 [V]	-207.5994	-246.7885	-39.18910	215.0794
AI 1/U2 [V]	-123.4374	-45.37750	78.05992	196.4523
AI 1/U3 [V]	322.2835	287.9675	-34.31606	214.9145
AI 1/I1 [A]	-61.22331	-86.07845	-24.85514	78.62894
AI 1/I2 [A]	-41.26791	-16.92537	24.34254	78.71541
AI 1/I3 [A]	102.6727	103.1019	0.429153	78.84826
U1_IRMS@POWER/0 [V]	231.1057	215.0886	-16.01707	215.0904
U2_IRMS@POWER/0 [V]	230.8752	196.4424	-34.43283	196.4749
U3_IRMS@POWER/0 [V]	230.9379	214.9007	-16.03717	214.9255
I1_IRMS_rc@POWER/0 [A]	72.73863	78.47808	5.739449	78.62732
I2_IRMS_rc@POWER/0 [A]	72.56937	78.59283	6.023453	78.71418
I3_IRMS_rc@POWER/0 [A]	73.15269	78.70010	5.547417	78.84772
P_t_rc@POWER/0 [W]	50526.70	49188.57	-1338.137	49280.91
P_fund_SYM+rc@POWER/0 [W]	50515.74	49186.09	-1329.648	49277.77
Q_t_rc@POWER/0 [var]	-618.9679	1984.073	2603.041	1988.562
Q_fund_SYM+rc@POWER/0 [var]	-41.05047	53.97670	95.02717	78.63563

t1 to t2

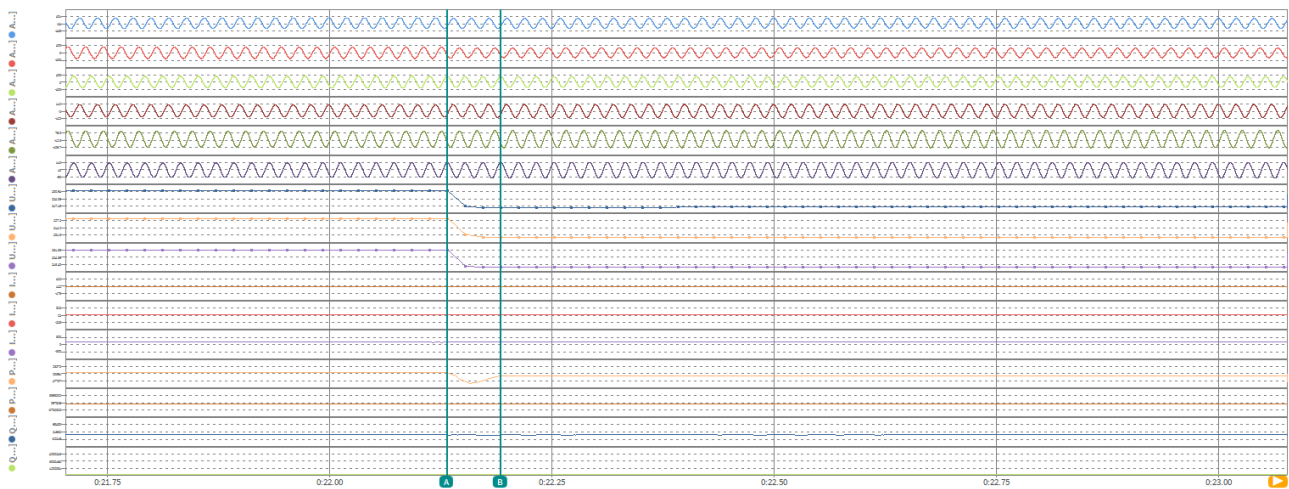

	A	B	Delta	RMS
Time [s]	0:22.13194	0:22.19241	0.06047	
AI 1/U1 [V]	-207.5994	-156.9960	50.60339	214.7902
AI 1/U2 [V]	-123.4374	-147.3274	-23.89002	198.4671
AI 1/U3 [V]	322.2835	304.3959	-17.88759	217.4896
AI 1/I1 [A]	-61.22331	-54.72640	6.496907	76.02486
AI 1/I2 [A]	-41.26791	-58.02873	-16.76083	76.18383
AI 1/I3 [A]	102.6727	112.9485	10.27584	76.59904
U1_IRMS@POWER/0 [V]	231.1057	214.5598	-16.54593	223.3695
U2_IRMS@POWER/0 [V]	230.8752	196.3383	-34.53690	215.4312
U3_IRMS@POWER/0 [V]	230.9379	215.2565	-15.68143	223.3667
I1_IRMS_rc@POWER/0 [A]	72.73863	78.69135	5.952721	74.99243
I2_IRMS_rc@POWER/0 [A]	72.56937	78.77541	6.206032	75.47066
I3_IRMS_rc@POWER/0 [A]	73.15269	78.45625	5.305565	75.22103
P_t_rc@POWER/0 [W]	50526.70	49213.37	-1313.336	48196.18
P_fund_SYM+rc@POWER/0 [W]	50515.74	49213.86	-1301.883	48203.99
Q_t_rc@POWER/0 [var]	-618.9679	-2181.516	-1562.548	2412.569
Q_fund_SYM+rc@POWER/0 [var]	-41.05047	-138.1688	-97.11829	430.0444

t1+60ms

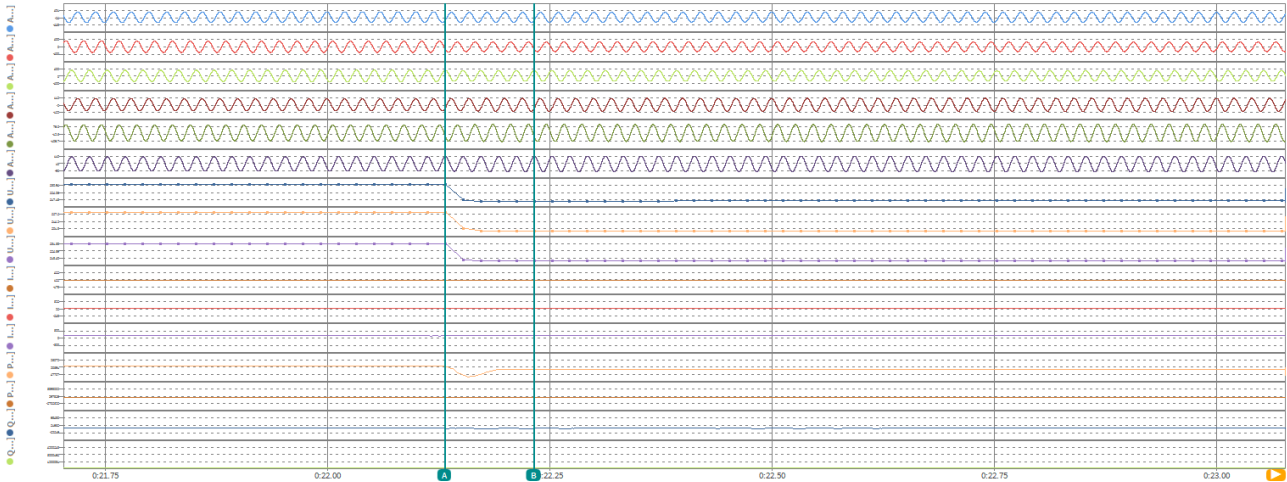

	A	B	Delta	RMS
Time [s]	0:22.13194	0:22.23215	0.10020	
AI 1/U1 [V]	-207.5994	-179.5418	28.05758	214.8780
AI 1/U2 [V]	-123.4374	-124.9895	-1.552105	197.8159
AI 1/U3 [V]	322.2835	304.3616	-17.92193	216.3099
AI 1/I1 [A]	-61.22331	-59.61398	1.609326	77.09961
AI 1/I2 [A]	-41.26791	-50.45894	-9.191037	77.24441
AI 1/I3 [A]	102.6727	110.2067	7.534028	77.34668
U1_IRMS@POWER/I [V]	231.1057	214.6735	-16.43216	220.5075
U2_IRMS@POWER/I [V]	230.8752	196.4584	-34.41679	209.2934
U3_IRMS@POWER/I [V]	230.9379	215.3580	-15.57994	220.7285
I1_IRMS_rc@POWER/I [A]	72.73863	78.53419	5.795563	76.45840
I2_IRMS_rc@POWER/I [A]	72.56937	78.63358	6.064201	76.78669
I3_IRMS_rc@POWER/I [A]	73.15269	78.68008	5.527390	76.67665
P_t_rc@POWER/I [W]	50526.70	49200.87	-1325.836	48631.13
P_fund_SYM+rc@POWER/I [W]	50515.74	49197.75	-1317.984	48634.13
Q_t_rc@POWER/I [var]	-618.9679	-2108.197	-1489.229	2302.223
Q_fund_SYM+rc@POWER/I [var]	-41.05047	-32.64997	8.400497	345.8408

t1+100ms

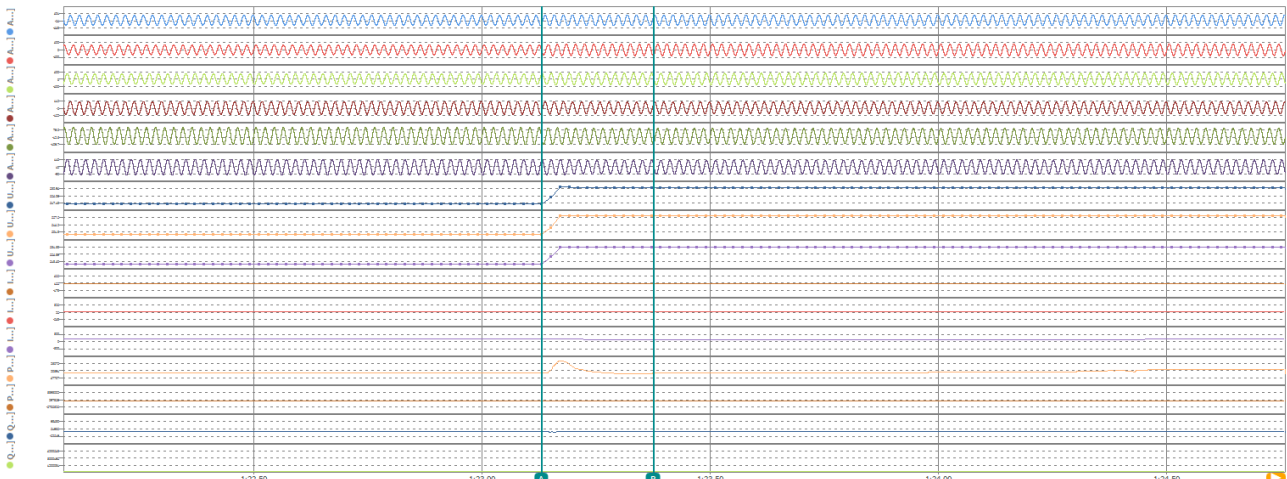

	A	B	Delta	RMS
Time [s]	1:23.13153	1:23.37624	0.24471	
AI 1/U1 [V]	-246.7885	177.5427	424.3312	229.1553
AI 1/U2 [V]	-45.37750	-325.5673	-280.1898	229.2595
AI 1/U3 [V]	287.9675	147.0389	-140.9285	230.6896
AI 1/I1 [A]	-86.07845	54.62429	140.7027	72.87670
AI 1/I2 [A]	-16.92537	-100.2169	-83.29154	72.87408
AI 1/I3 [A]	103.1019	45.71451	-57.38736	73.28822
U1_IRMS@POWER/I [V]	215.0886	231.2742	16.18555	228.4873
U2_IRMS@POWER/I [V]	196.4424	230.8350	34.39265	224.7491
U3_IRMS@POWER/I [V]	214.9007	230.6467	15.74597	227.6059
I1_IRMS_rc@POWER/I [A]	78.47898	70.84213	-7.636848	73.19304
I2_IRMS_rc@POWER/I [A]	78.59283	70.87333	-7.719498	73.11320
I3_IRMS_rc@POWER/I [A]	78.70010	70.87674	-7.823364	73.26492
P_t_rc@POWER/I [W]	49188.57	49091.87	-96.69531	50147.31
P_fund_SYM+rc@POWER/I [W]	49186.09	49090.51	-95.58203	50145.58
Q_t_rc@POWER/I [var]	1984.073	485.2939	-1498.780	1087.811
Q_fund_SYM+rc@POWER/I [var]	53.97670	24.58426	-29.39244	268.3046

Active power rising time

Condition						Measurement
No.	Parameter	Phase ref.	Time ref.	unit		
General Info.	0	Test number	--	--	--	4.4
	1	Date	--	--	dd.mm.yyyy	14.06.2025
	2	Time (start of test)	--	--	hh:mm:ss.f	10:27:21
	3	Fault type (phase)	--	--		D1
	4	Setting voltage depth	Line to line	--	p.u.	0.85
	5	Setting dip duration		--		60000
	6	Point of fault entry	Total	--	ms	19362
	7	Point of fault clearance	Total	--	ms	80382
	8	Fault duration in empty load test	Total	--	ms	60005
	9	Voltage depth/height in empty load test	Total	t1+100ms to t2 and t1-10s to t1	p.u.	0.850
10	Pos.		p.u.		1.000	
Before dip <t1	11	Voltage	Line to neutral	t1-100s to t1	p.u.	1.001
	12	Current	Pos.	t1-500ms to t1-100ms	p.u.	0.500
	13	Active power	Total	t1-10s to t1	p.u.	0.499
	14		Pos.			0.499
	15	Reactive power	Total	t1-10s to t1	p.u.	0.007
	16		Pos.			0.001
17	Cos ϕ	--	t1-10s to t1	--	0.999	
During dip t1 to t2	18	Voltage	Line to neutral	t1+100ms to t2-20ms	p.u.	0.851
	19	Line current	Phase 1	t1+60ms	p.u.	0.550
	20		Phase 2			0.547
	21		Phase 3			0.548
	22	Line current	Phase 1	t1+100ms	p.u.	0.553
	23		Phase 2			0.556
	24		Phase 3			0.558
	25	Active power	Total	t1+100ms to t2-20ms	p.u.	0.502
26	Pos.		0.500			
After dip > t2	27	Voltage	Line to neutral	t2+3s to t2+10s	p.u.	1.001
	28	Active power	Total	t2+3s to t2+10s	p.u.	0.499
	29		Pos.			0.499
	39	Active power rising time	Pos.	--	s	0.213
	31	Reactive power	Total	t2+3s to t2+10s	p.u.	0.006
	32		Pos.			0.001
	33	Reactive power rising time	Pos.	--	s	--
	34	PGU does not disconnect from grid till 60s after fault	--	t2 to t2+60s	Yes / No	Yes

Test No. 4.4 idle test

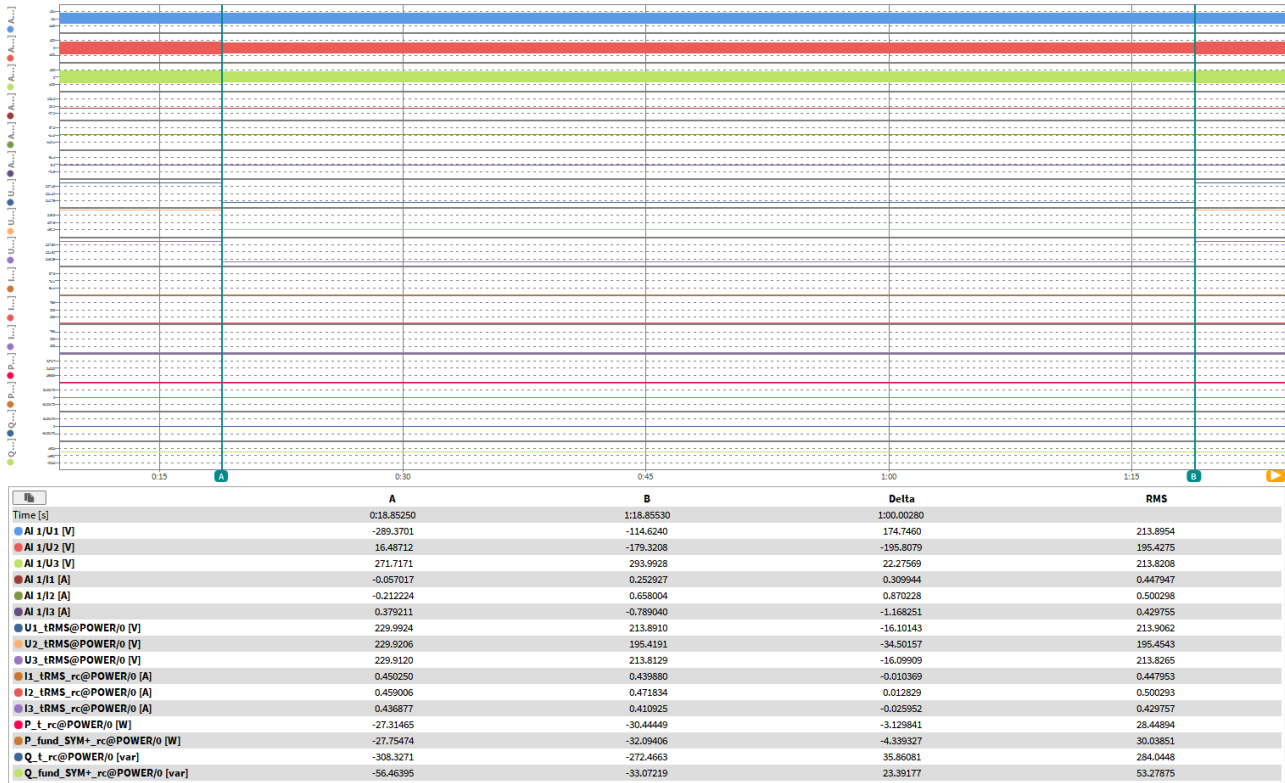

Test No. 4.4 with PGU

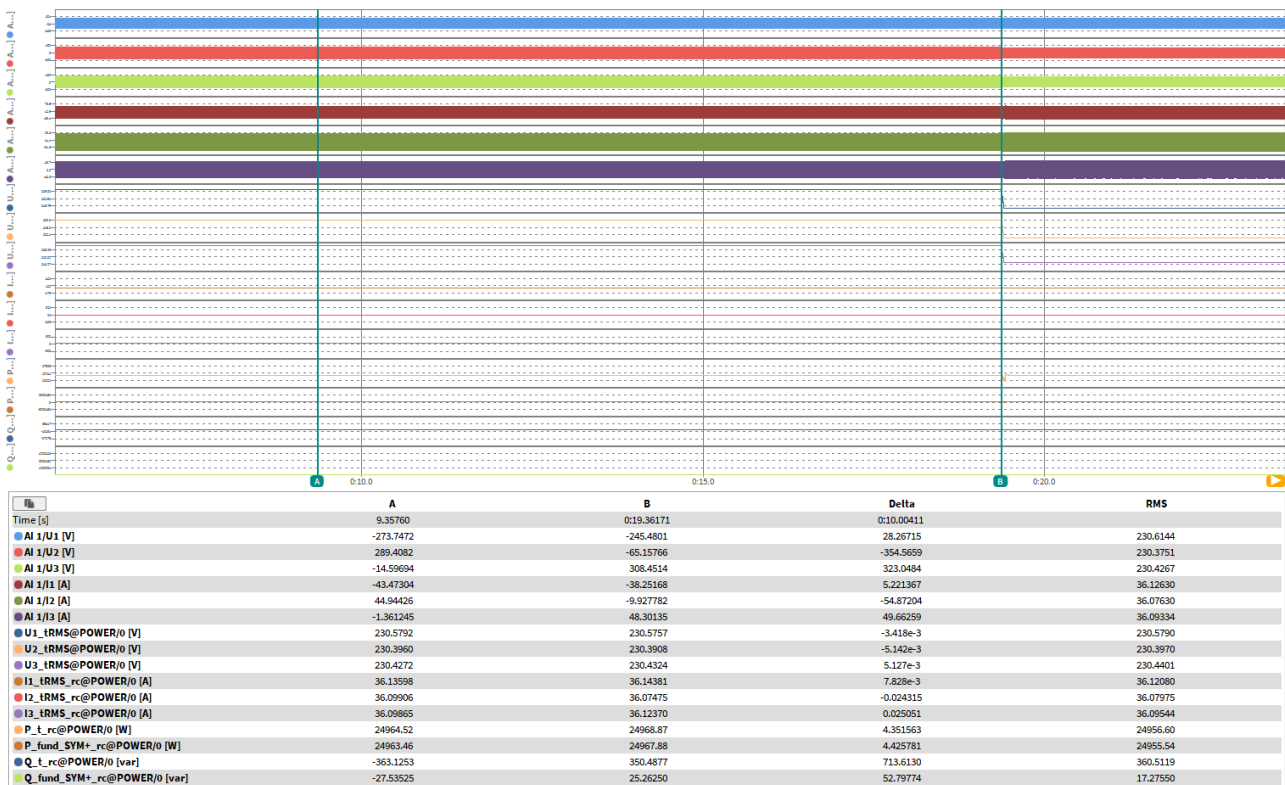

t1-10s to t1



	A	B	Delta	RMS
Time [s]	0:19.36291	1:20.38260	1:01.01970	
AI 1/U1 [V]	-149.6432	-194.5369	-44.89374	214.5598
AI 1/U2 [V]	-176.3404	-99.90693	76.43342	195.9579
AI 1/U3 [V]	325.2399	300.2320	-25.00796	214.3873
AI 1/I1 [A]	-23.51741	-36.49930	-12.98189	39.87555
AI 1/I2 [A]	-27.29658	-19.28571	8.010865	39.91898
AI 1/I3 [A]	50.93587	55.91882	4.982949	40.06708
U1_IRMS@POWER/0 [V]	230.5757	214.5705	-16.00523	214.5703
U2_IRMS@POWER/0 [V]	230.3908	195.9430	-34.44777	195.9811
U3_IRMS@POWER/0 [V]	230.4324	214.3855	-16.04684	214.3985
I1_IRMS_rc@POWER/0 [A]	36.14455	39.94670	3.802155	39.87470
I2_IRMS_rc@POWER/0 [A]	36.07444	40.13764	4.063206	39.91827
I3_IRMS_rc@POWER/0 [A]	36.12102	39.95897	3.837948	40.06656
P_t_rc@POWER/0 [W]	24967.66	24957.37	-10.28906	24946.17
P_fund_SYM+rc@POWER/0 [W]	24966.66	24954.07	-12.58984	24943.47
Q_t_rc@POWER/0 [var]	349.4126	1035.281	685.8679	1041.093
Q_fund_SYM+rc@POWER/0 [var]	26.14711	7.012113	-19.13500	18.19961

t1 to t2

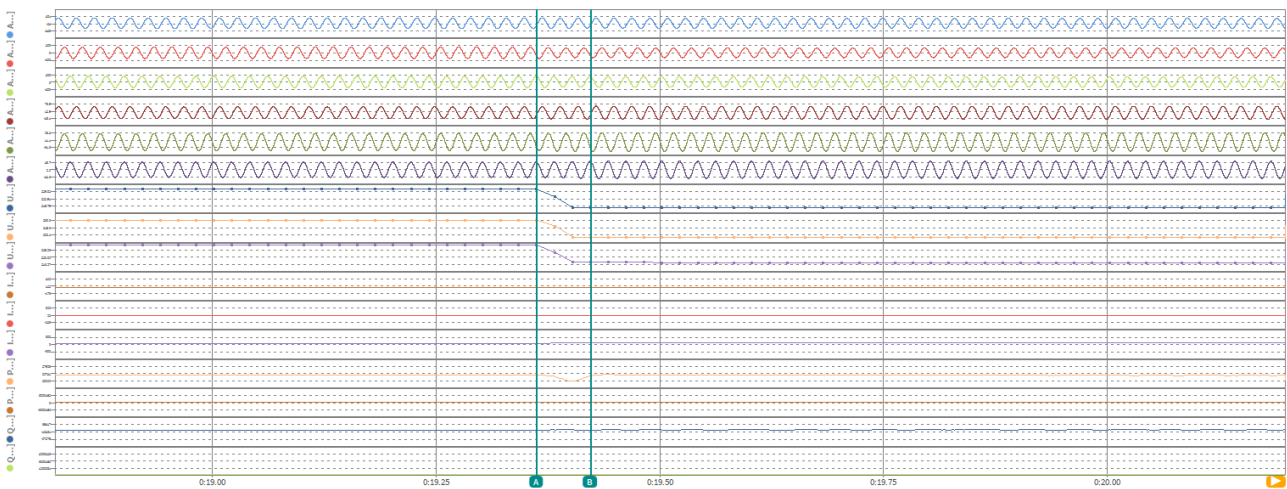

	A	B	Delta	RMS
Time [s]	0:19.36291	0:19.42295	0.06004	
AI 1/U1 [V]	-149.6432	-151.6655	-2.022267	217.7864
AI 1/U2 [V]	-176.3404	-150.7013	25.63906	204.7397
AI 1/U3 [V]	325.2399	302.2008	-23.03910	218.4962
AI 1/I1 [A]	-23.51741	-26.19962	-2.682209	37.88120
AI 1/I2 [A]	-27.29658	-30.98014	-3.683567	38.10613
AI 1/I3 [A]	50.93587	57.31357	6.377697	37.98651
U1_IRMS@POWER/0 [V]	230.5757	214.2944	-16.28133	225.0363
U2_IRMS@POWER/0 [V]	230.3908	195.8855	-34.50533	219.4334
U3_IRMS@POWER/0 [V]	230.4324	214.6374	-15.79494	224.7896
I1_IRMS_rc@POWER/0 [A]	36.14455	39.85169	3.707146	37.13720
I2_IRMS_rc@POWER/0 [A]	36.07444	39.54189	3.467453	37.54629
I3_IRMS_rc@POWER/0 [A]	36.12102	39.54480	3.423782	37.22246
P_t_rc@POWER/0 [W]	24967.66	24734.06	-233.5938	24250.30
P_fund_SYM+rc@POWER/0 [W]	24966.66	24728.57	-238.0957	24258.61
Q_t_rc@POWER/0 [var]	349.4126	-1286.965	-1636.377	1374.340
Q_fund_SYM+rc@POWER/0 [var]	26.14711	-618.0089	-644.1560	304.2985

t1+60ms

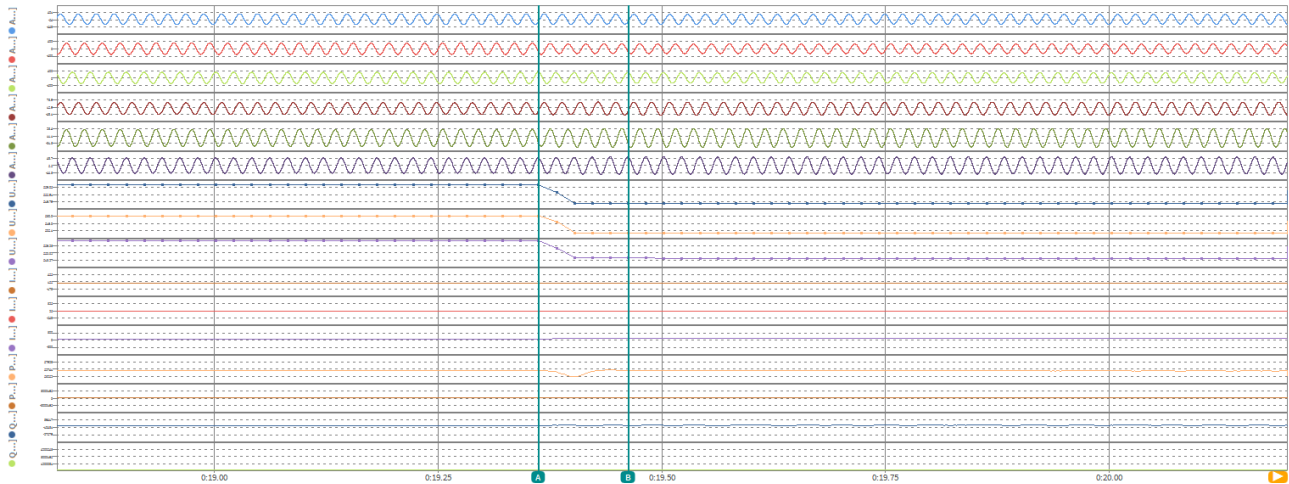

	A	B	Delta	RMS
Time [s]	0:19.36291	0:19.46302	0.10012	
AI 1/U1 [V]	-149.6432	-143.4720	6.171227	216.3637
AI 1/U2 [V]	-176.3404	-157.7315	18.60881	201.2420
AI 1/U3 [V]	325.2399	301.0130	-24.22691	217.0660
AI 1/I1 [A]	-23.51741	-24.47108	-0.953674	38.84091
AI 1/I2 [A]	-27.29658	-31.87421	-4.577637	39.00275
AI 1/I3 [A]	50.93587	56.51487	5.578995	39.01016
U1_IRMS@POWER/0 [V]	230.5757	214.3942	-16.18158	221.5217
U2_IRMS@POWER/0 [V]	230.3908	196.0108	-34.37996	211.8955
U3_IRMS@POWER/0 [V]	230.4324	214.7030	-15.72934	221.4578
I1_IRMS@POWER/0 [A]	36.14455	40.18238	4.037838	38.38390
I2_IRMS@POWER/0 [A]	36.07444	40.21732	4.142879	38.62869
I3_IRMS@POWER/0 [A]	36.12102	40.41907	4.298050	38.50471
P_t_rc@POWER/0 [W]	24967.66	25145.44	177.7832	24607.60
P_fund_SYM+rc@POWER/0 [W]	24966.66	25141.64	174.9766	24611.05
Q_t_rc@POWER/0 [var]	349.4126	-1064.520	-1413.932	1288.021
Q_fund_SYM+rc@POWER/0 [var]	26.14711	-91.06312	-117.2102	287.3186

t1+100ms

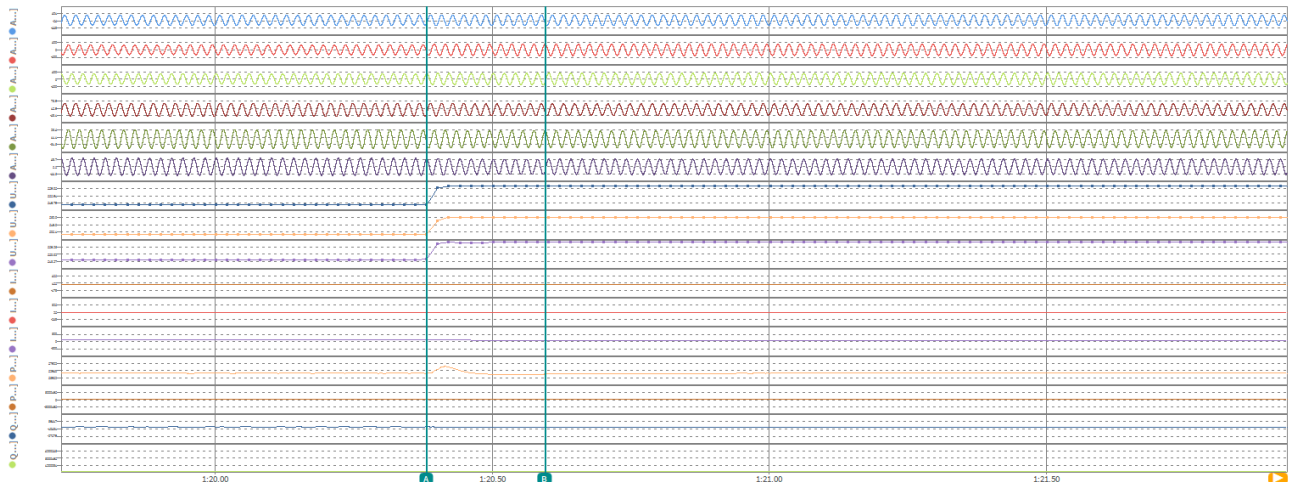

	A	B	Delta	RMS
Time [s]	1:20.38263	1:20.59604	0.21342	
AI 1/U1 [V]	-194.5369	-120.3325	74.20445	229.1168
AI 1/U2 [V]	-99.90693	322.0113	421.9182	229.8318
AI 1/U3 [V]	300.2320	-202.9514	-503.1834	231.0479
AI 1/I1 [A]	-36.49930	-18.57022	17.92908	36.29421
AI 1/I2 [A]	-19.28571	50.14178	69.42749	36.45754
AI 1/I3 [A]	55.91882	-31.44967	-87.36849	36.71412
U1_IRMS@POWER/0 [V]	214.5705	230.6863	16.11580	228.0038
U2_IRMS@POWER/0 [V]	195.9430	230.3782	34.43517	224.5229
U3_IRMS@POWER/0 [V]	214.3655	230.3425	15.97692	227.6237
I1_IRMS@POWER/0 [A]	39.94670	35.78211	-4.164589	36.70713
I2_IRMS@POWER/0 [A]	40.13764	35.72396	-4.413666	36.61334
I3_IRMS@POWER/0 [A]	39.95897	35.75895	-4.200016	36.76047
P_t_rc@POWER/0 [W]	24957.37	24718.83	-238.5332	25186.31
P_fund_SYM+rc@POWER/0 [W]	24954.07	24717.73	-236.3457	25185.69
Q_t_rc@POWER/0 [var]	1035.281	-377.4911	-1412.772	664.7192
Q_fund_SYM+rc@POWER/0 [var]	7.012113	-2.345785	-9.357898	168.8364

Active power rising time

Condition						Measurement
No.	Parameter	Phase ref.	Time ref.	unit		
General Info.	0	Test number	--	--	--	5.1
	1	Date	--	--	dd.mm.yyyy	15.05.2025
	2	Time (start of test)	--	--	hh:mm:ss.f	10:28:13
	3	Fault type (phase)	--	--		A
	4	Setting voltage depth	Line to line	--	p.u.	1.25
	5	Setting dip duration		--		100
	6	Point of fault entry	Total	--	ms	18292
	7	Point of fault clearance	Total	--	ms	18393
	8	Fault duration in empty load test	Total	--	ms	101
	9	Voltage depth/height in empty load test	Total	t1+100ms to t2 and t1-10s to t1	p.u.	1.250
10	Pos.		p.u.		1.000	
Before dip <t1	11	Voltage	Line to neutral	t1-100s to t1	p.u.	1.003
	12	Current	Pos.	t1-500ms to t1-100ms	p.u.	1.008
	13	Active power	Total	t1-10s to t1	p.u.	1.009
	14		Pos.			1.009
	15	Reactive power	Total	t1-10s to t1	p.u.	0.012
	16		Pos.			0.008
17	Cos ϕ	--	t1-10s to t1	--	0.999	
During dip t1 to t2	18	Voltage	Line to neutral	t1+100ms to t2-20ms	p.u.	1.248
	19	Line current	Phase 1	t1+60ms	p.u.	0.049
	20		Phase 2			0.043
	21		Phase 3			0.070
	22	Line current	Phase 1	t1+100ms	p.u.	0.038
	23		Phase 2			0.028
	24		Phase 3			0.036
	25	Active power	Total	t1+100ms to t2-20ms	p.u.	0.001
26	Pos.		0.001			
After dip > t2	27	Voltage	Line to neutral	t2+3s to t2+10s	p.u.	1.003
	28	Active power	Total	t2+3s to t2+10s	p.u.	1.010
	29		Pos.			1.010
	39	Active power rising time	Pos.	--	s	0.439
	31	Reactive power	Total	t2+3s to t2+10s	p.u.	0.013
	32		Pos.			0.008
	33	Reactive power rising time	Pos.	--	s	--
	34	PGU does not disconnect from grid till 60s after fault	--	t2 to t2+60s	Yes / No	Yes

Test No. 5.1 idle test



Test No. 5.1 with PGU

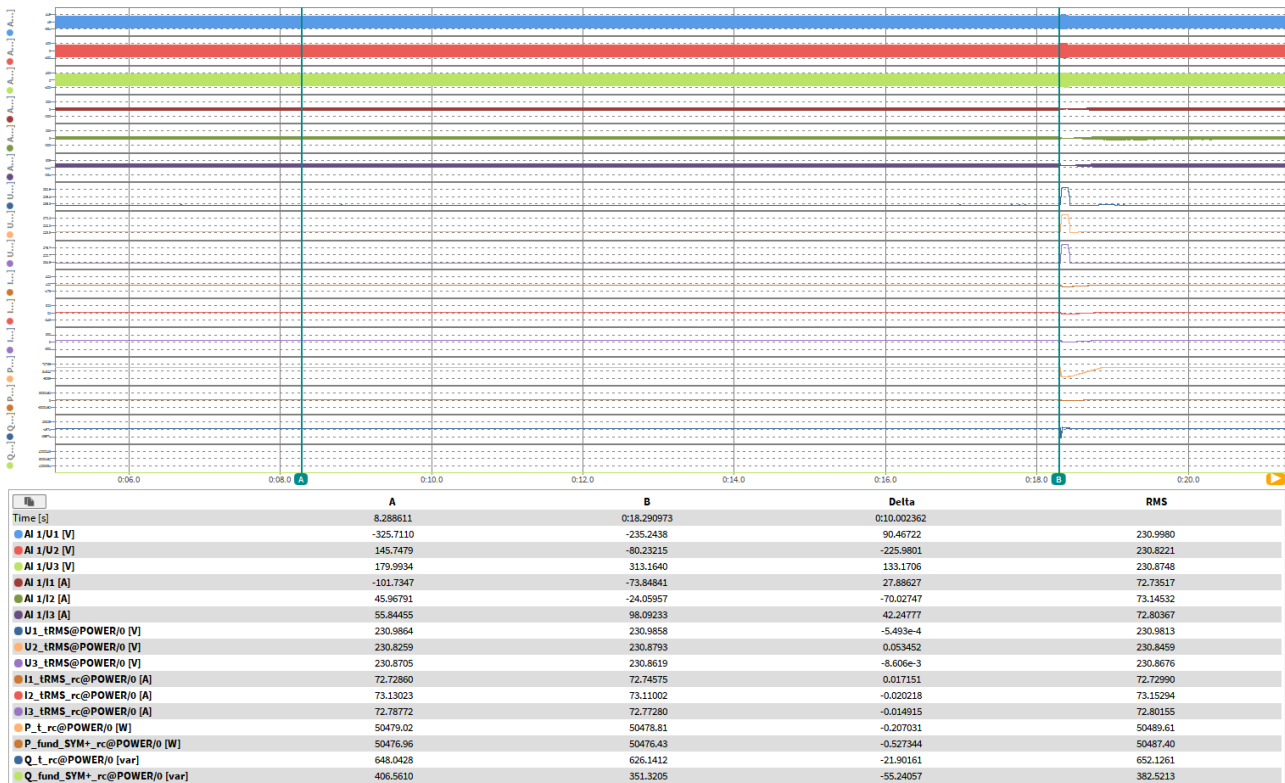

t1-10s to t1

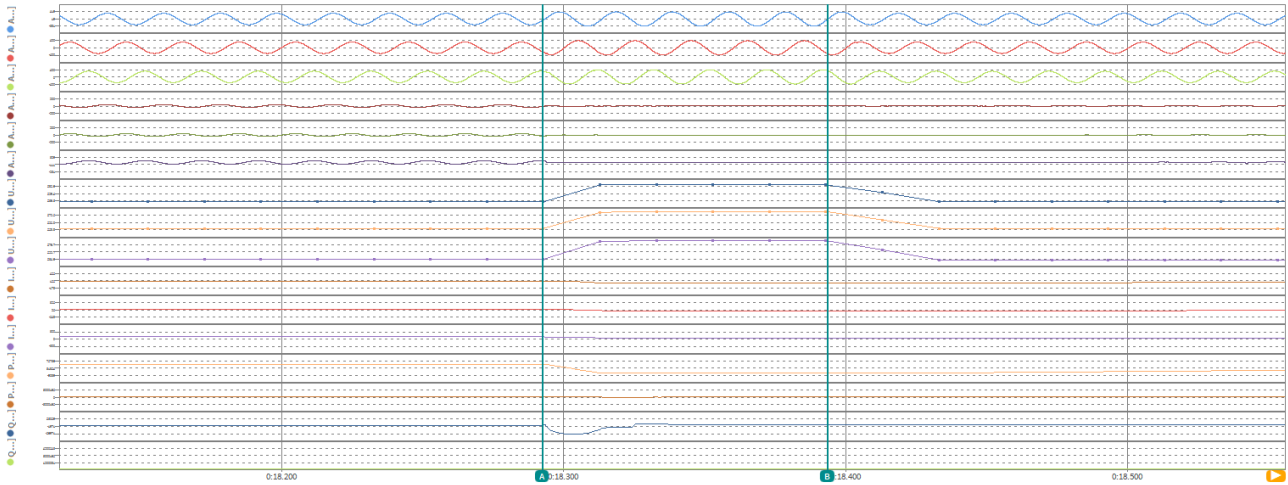

	A	B	Delta	RMS
Time [s]	0:18.292578	0:18.393652	0:0.101074	
AI 1/U1 [V]	-99.31541	2.794266	102.1097	285.4094
AI 1/U2 [V]	-220.4735	-352.4523	-131.9788	286.2062
AI 1/U3 [V]	319.1991	349.2432	30.04408	286.7132
AI 1/I1 [A]	-33.33501	-0.457560	32.87745	5.366522
AI 1/I2 [A]	-68.75912	0.227181	68.98630	11.15743
AI 1/I3 [A]	102.2480	0.310546	-101.9374	12.57213
U1_IRMS@POWER/0 [V]	230.9858	287.2783	56.29243	272.0741
U2_IRMS@POWER/0 [V]	230.8793	287.1535	56.27423	271.7199
U3_IRMS@POWER/0 [V]	230.8619	287.1257	56.26379	271.7362
I1_IRMS_rc@POWER/0 [A]	72.70428	2.793020	-69.91126	25.47430
I2_IRMS_rc@POWER/0 [A]	73.12238	2.087996	-71.03439	24.91150
I3_IRMS_rc@POWER/0 [A]	72.76664	2.621125	-70.14552	27.59170
P_t_rc@POWER/0 [W]	50471.30	72.57020	-50398.73	14978.13
P_fund_SYM+rc@POWER/0 [W]	50469.07	70.30311	-50398.76	15595.97
Q_t_rc@POWER/0 [var]	618.2675	2153.200	1534.932	12049.30
Q_fund_SYM+rc@POWER/0 [var]	335.1676	1364.180	1029.012	2450.938

t1 to t2

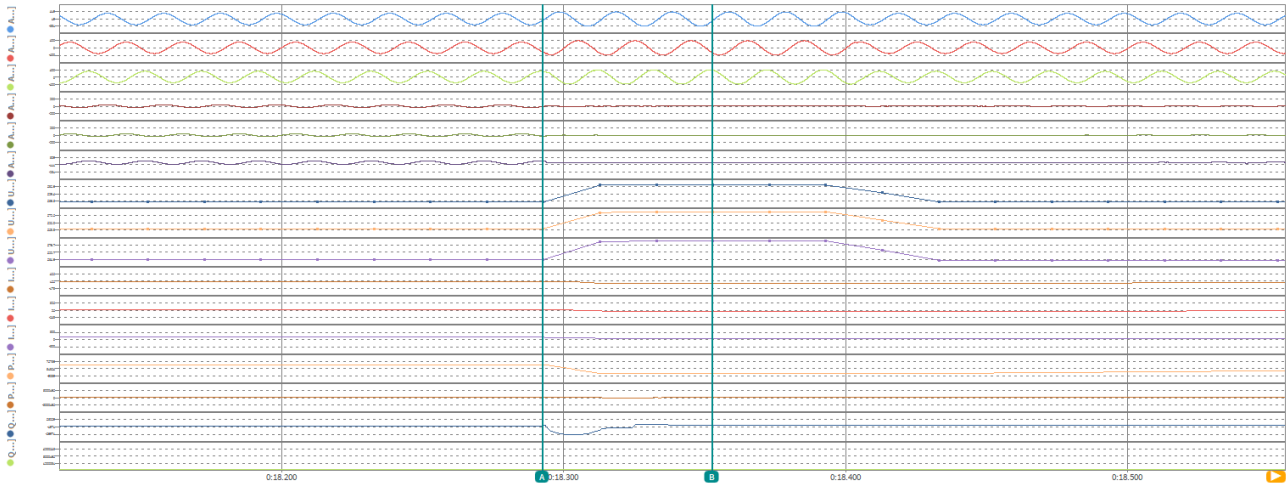

	A	B	Delta	RMS
Time [s]	0:18.292578	0:18.352674	0:0.060096	
AI 1/U1 [V]	-99.31541	-121.2111	-21.89565	285.4121
AI 1/U2 [V]	-220.4735	-273.3927	-52.91915	285.0100
AI 1/U3 [V]	319.1991	394.2523	75.05322	284.7965
AI 1/I1 [A]	-33.33501	1.404608	34.73962	6.515101
AI 1/I2 [A]	-68.75912	-1.831960	66.92715	14.34968
AI 1/I3 [A]	102.2480	0.571019	-101.6769	16.09408
U1_IRMS@POWER/0 [V]	230.9858	287.2973	56.31151	260.1323
U2_IRMS@POWER/0 [V]	230.8793	287.2117	56.33237	259.5772
U3_IRMS@POWER/0 [V]	230.8619	287.1821	56.32025	259.6134
I1_IRMS_rc@POWER/0 [A]	72.70428	3.569945	-69.13433	32.84197
I2_IRMS_rc@POWER/0 [A]	73.12238	3.111639	-70.01074	32.14978
I3_IRMS_rc@POWER/0 [A]	72.76664	5.124230	-67.64241	35.55520
P_t_rc@POWER/0 [W]	50471.30	526.5487	-49944.76	19367.84
P_fund_SYM+rc@POWER/0 [W]	50469.07	519.4760	-49949.59	20166.81
Q_t_rc@POWER/0 [var]	618.2675	3346.888	2728.620	15430.82
Q_fund_SYM+rc@POWER/0 [var]	335.1676	1522.807	1187.640	2953.007

t1+60ms

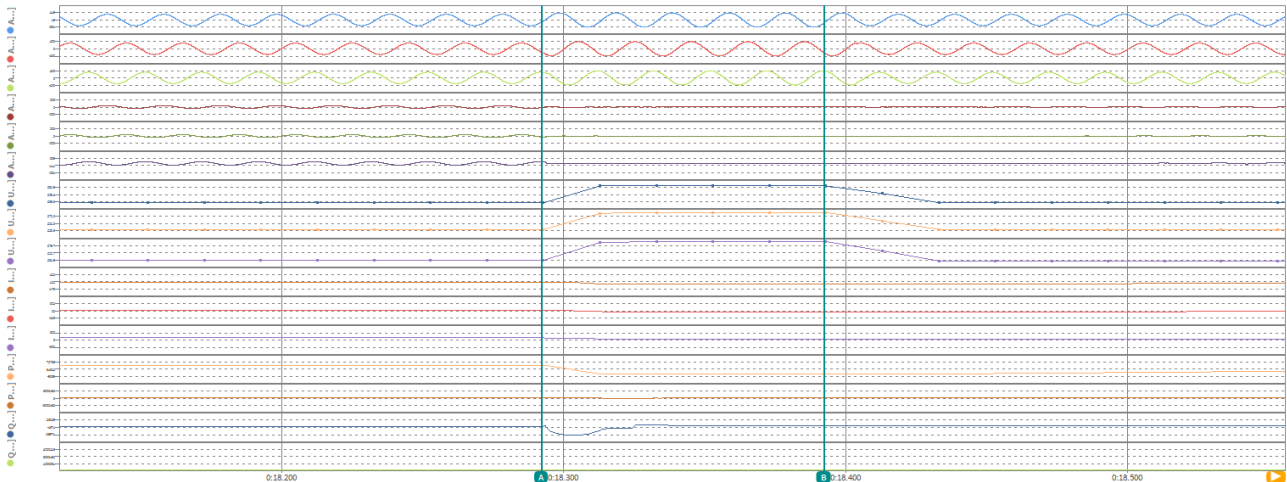

	A	B	Delta	RMS
Time [s]	0:18.292285	0:18.392333	0.100049	
AI 1/U1 [V]	-128.0744	-158.7989	-30.72453	286.7308
AI 1/U2 [V]	-196.5461	-243.8343	-47.28818	285.6996
AI 1/U3 [V]	324.4360	402.1192	77.68322	285.4018
AI 1/I1 [A]	-41.14417	1.304353	42.44852	5.790658
AI 1/I2 [A]	-61.84629	0.979869	62.82616	11.74970
AI 1/I3 [A]	103.1065	-2.185339	-105.2918	13.82995
U1_IRMS@POWER/0 [V]	230.9858	287.2252	56.23936	269.4567
U2_IRMS@POWER/0 [V]	230.8793	287.1186	56.23932	269.0616
U3_IRMS@POWER/0 [V]	230.8619	287.0782	56.21631	269.0857
I1_IRMS_rc@POWER/0 [A]	72.70428	2.810937	-69.89334	25.59859
I2_IRMS_rc@POWER/0 [A]	73.12238	2.080470	-71.04191	25.03365
I3_IRMS_rc@POWER/0 [A]	72.76664	2.609265	-70.15737	27.72673
P_t_rc@POWER/0 [W]	50471.30	92.99247	-50378.31	15052.10
P_fund_SYM+rc@POWER/0 [W]	50469.07	90.51978	-50378.55	15672.99
Q_t_rc@POWER/0 [var]	618.2675	2151.715	1533.448	12106.90
Q_fund_SYM+rc@POWER/0 [var]	335.1676	1337.731	1002.563	2459.298

t1+100ms

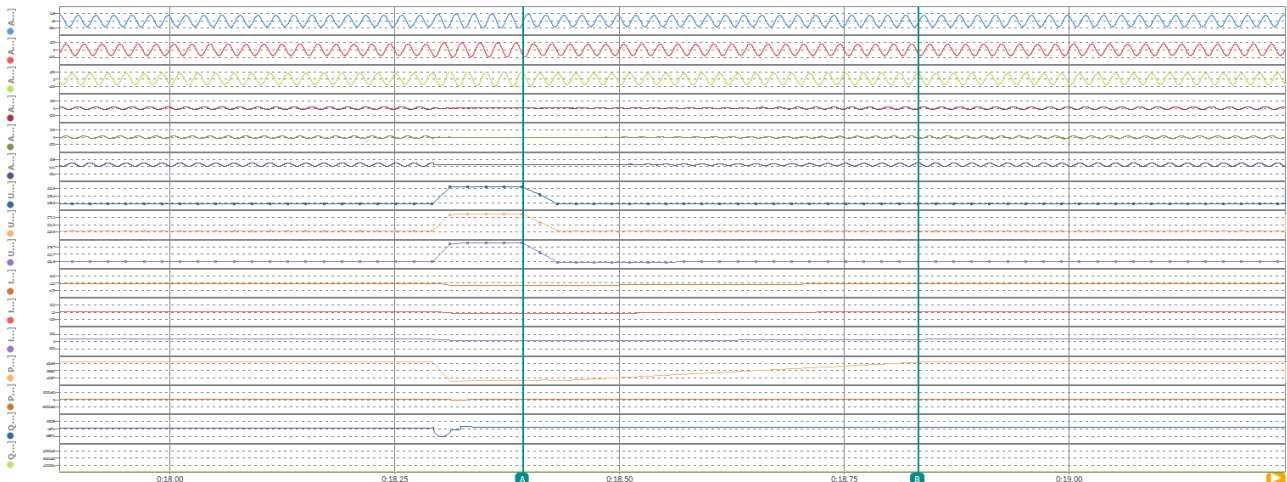

	A	B	Delta	RMS
Time [s]	0:18.392608	0:18.832098	0.439491	
AI 1/U1 [V]	-123.1866	-144.2387	-21.05212	231.9958
AI 1/U2 [V]	-273.1414	-380.9883	-107.8469	232.0011
AI 1/U3 [V]	396.1108	324.5759	-71.53488	231.9679
AI 1/I1 [A]	1.544202	-47.18058	-48.73479	41.35120
AI 1/I2 [A]	0.740735	-55.78903	-56.52976	41.13747
AI 1/I3 [A]	-2.187961	103.0786	105.2666	41.24696
U1_IRMS@POWER/0 [V]	287.2252	231.0179	-56.20728	237.2750
U2_IRMS@POWER/0 [V]	287.1186	230.9225	-56.19617	237.1701
U3_IRMS@POWER/0 [V]	287.0782	230.9111	-56.16713	237.1639
I1_IRMS_rc@POWER/0 [A]	2.810937	72.12768	69.31674	39.68700
I2_IRMS_rc@POWER/0 [A]	2.080470	72.20541	70.12494	39.86522
I3_IRMS_rc@POWER/0 [A]	2.609265	72.06526	69.45600	39.72183
P_t_rc@POWER/0 [W]	92.99247	49953.70	49860.71	27467.27
P_fund_SYM+rc@POWER/0 [W]	90.51978	49944.95	49854.43	27462.24
Q_t_rc@POWER/0 [var]	2151.715	1726.692	-425.0232	1698.944
Q_fund_SYM+rc@POWER/0 [var]	1337.731	78.74997	-1258.981	790.2874

Active power rising time

Condition						Measurement
No.	Parameter	Phase ref.	Time ref.	unit		
General Info.	0	Test number	--	--	--	5.2
	1	Date	--	--	dd.mm.yyyy	15.05.2025
	2	Time (start of test)	--	--	hh:mm:ss.f	10:26:27
	3	Fault type (phase)	--	--		A
	4	Setting voltage depth	Line to line	--	p.u.	1.25
	5	Setting dip duration		--		100
	6	Point of fault entry	Total	--	ms	21326
	7	Point of fault clearance	Total	--	ms	21427
	8	Fault duration in empty load test	Total	--	ms	101
	9	Voltage depth/height in empty load test	Total	t1+100ms to t2 and t1-10s to t1	p.u.	1.250
10	Pos.		p.u.		1.000	
Before dip <t1	11	Voltage	Line to neutral	t1-100s to t1	p.u.	1.001
	12	Current	Pos.	t1-500ms to t1-100ms	p.u.	0.499
	13	Active power	Total	t1-10s to t1	p.u.	0.499
	14		Pos.			0.499
	15	Reactive power	Total	t1-10s to t1	p.u.	0.009
	16		Pos.			0.002
17	Cos ϕ	--	t1-10s to t1	--	0.999	
During dip t1 to t2	18	Voltage	Line to neutral	t1+100ms to t2-20ms	p.u.	1.249
	19	Line current	Phase 1	t1+60ms	p.u.	0.027
	20		Phase 2			0.033
	21		Phase 3			0.030
	22	Line current	Phase 1	t1+100ms	p.u.	0.031
	23		Phase 2			0.026
	24		Phase 3			0.026
	25	Active power	Total	t1+100ms to t2-20ms	p.u.	0.002
26	Pos.		0.002			
After dip > t2	27	Voltage	Line to neutral	t2+3s to t2+10s	p.u.	1.001
	28	Active power	Total	t2+3s to t2+10s	p.u.	0.501
	29		Pos.			0.501
	39	Active power rising time	Pos.	--	s	0.248
	31	Reactive power	Total	t2+3s to t2+10s	p.u.	0.025
	32		Pos.			0.002
	33	Reactive power rising time	Pos.	--	s	--
	34	PGU does not disconnect from grid till 60s after fault	--	t2 to t2+60s	Yes / No	Yes

Test No. 5.2 idle test

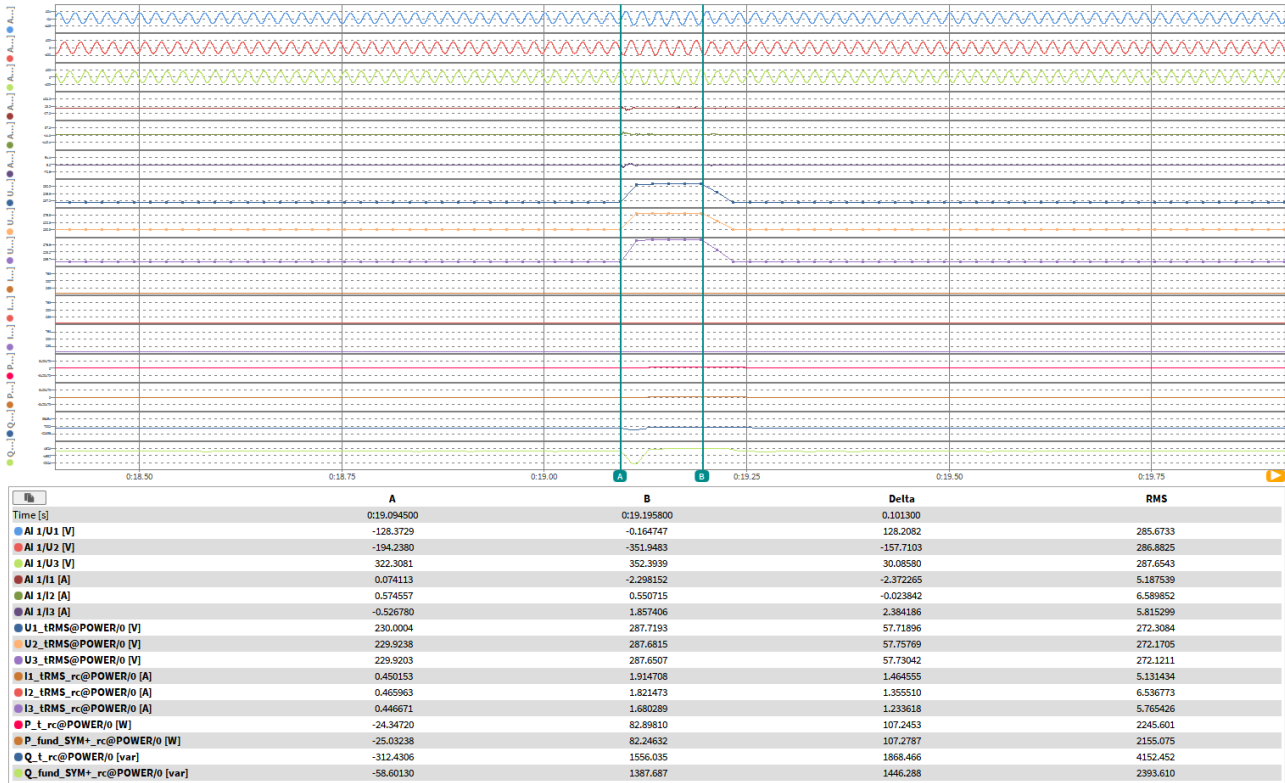

Test No. 5.2 with PGU

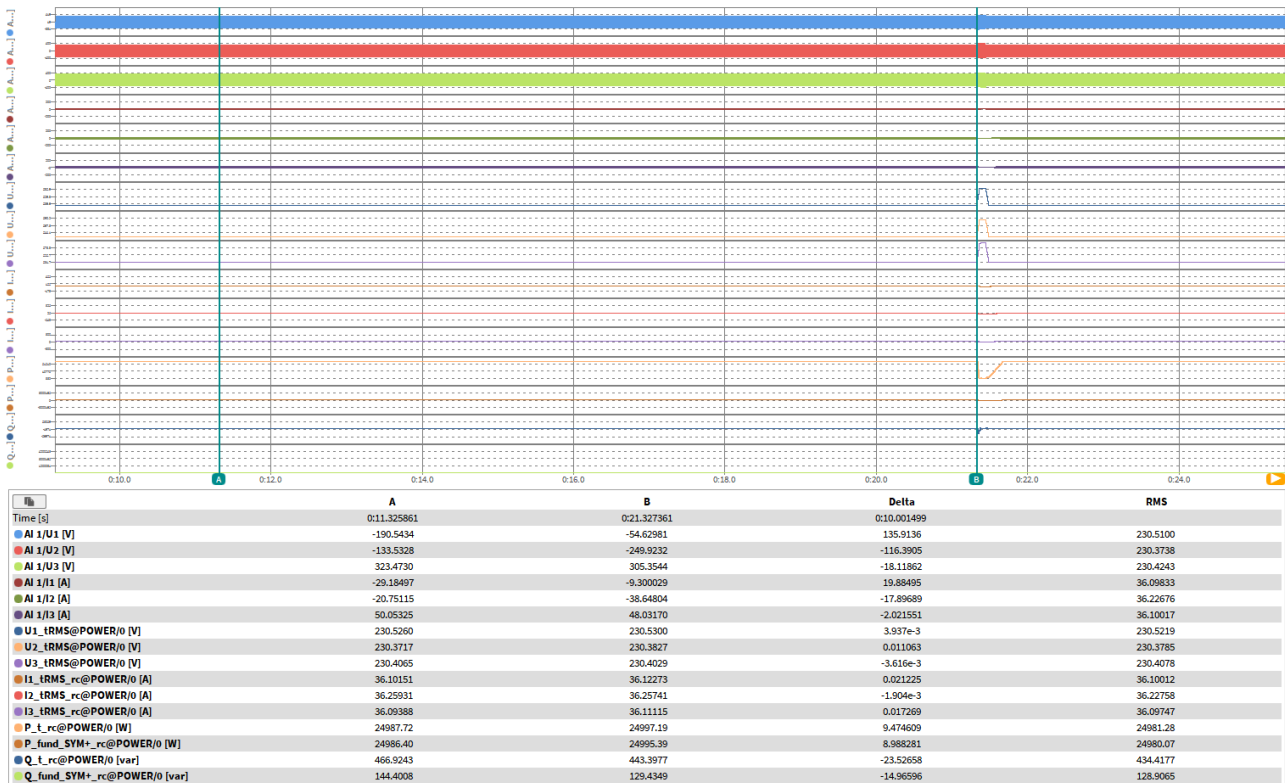

t1-10s to t1

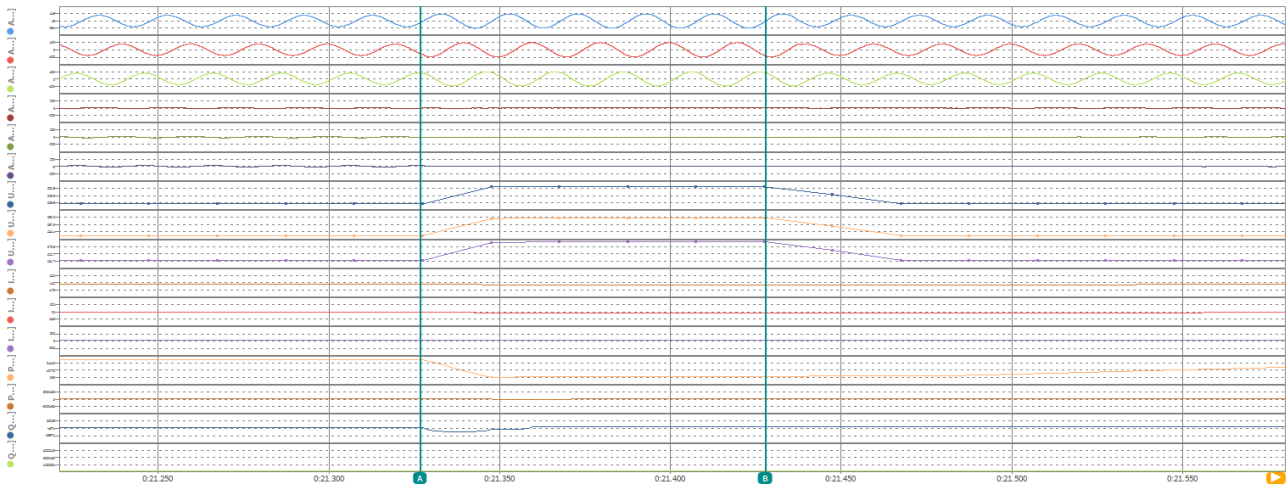

	A	B	Delta	RMS
Time [s]	0:21.326924	0:21.427948	0.101024	
AI 1/U1 [V]	-96.56406	-0.270367	96.29369	285.7369
AI 1/U2 [V]	-220.9554	-351.4323	-130.4770	286.6111
AI 1/U3 [V]	317.2138	351.4524	34.23858	287.0810
AI 1/I1 [A]	-16.60482	-0.528252	16.07657	4.402155
AI 1/I2 [A]	-33.85249	-0.174792	33.67770	5.947973
AI 1/I3 [A]	50.55834	0.791317	-49.76702	6.599518
U1_IRMS@POWER/0 [V]	230.5300	287.5105	56.98058	272.1615
U2_IRMS@POWER/0 [V]	230.3827	287.3553	56.97252	271.9112
U3_IRMS@POWER/0 [V]	230.4029	287.3639	56.96100	271.9150
I1_IRMS@POWER/0 [A]	36.12157	2.308524	-33.81305	13.29775
I2_IRMS@POWER/0 [A]	36.25351	1.940969	-34.31254	12.72983
I3_IRMS@POWER/0 [A]	36.09959	1.877131	-34.22246	14.03928
P_t_rc@POWER/0 [W]	24992.78	104.3493	-24888.43	7413.210
P_fund_SYM+rc@POWER/0 [W]	24991.17	103.1682	-24888.00	7734.009
Q_t_rc@POWER/0 [var]	440.1808	1757.748	1317.567	6627.805
Q_fund_SYM+rc@POWER/0 [var]	129.1428	1448.892	1319.749	2210.355

t1 to t2

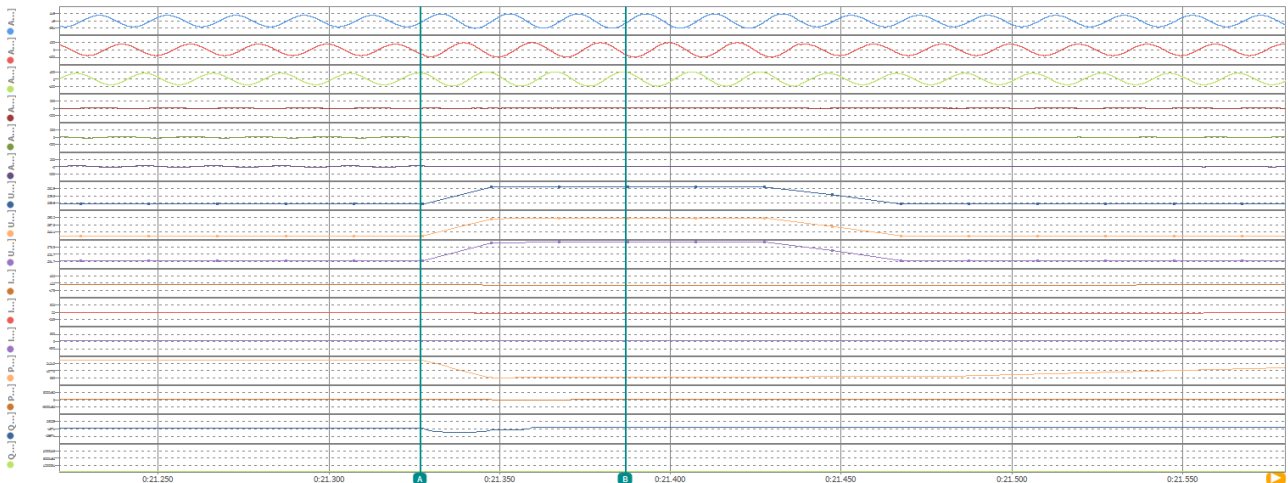

	A	B	Delta	RMS
Time [s]	0:21.326924	0:21.386953	0.060029	
AI 1/U1 [V]	-96.56406	-127.0676	-30.50351	285.8005
AI 1/U2 [V]	-220.9554	-270.4399	-49.48449	285.5798
AI 1/U3 [V]	317.2138	397.3809	80.16706	285.1718
AI 1/I1 [A]	-16.60482	1.273239	17.87806	5.379725
AI 1/I2 [A]	-33.85249	-1.084121	32.76837	7.530141
AI 1/I3 [A]	50.55834	-0.095004	-50.65334	8.408954
U1_IRMS@POWER/0 [V]	230.5300	287.3588	56.82884	260.0893
U2_IRMS@POWER/0 [V]	230.3827	287.3004	56.91768	259.7420
U3_IRMS@POWER/0 [V]	230.4029	287.4238	57.02090	259.7345
I1_IRMS@POWER/0 [A]	36.12157	2.012283	-34.10929	17.09660
I2_IRMS@POWER/0 [A]	36.25351	2.424625	-33.82868	16.37165
I3_IRMS@POWER/0 [A]	36.09959	2.197621	-33.90197	18.07943
P_t_rc@POWER/0 [W]	24992.78	259.1401	-24733.64	9585.402
P_fund_SYM+rc@POWER/0 [W]	24991.17	257.2287	-24733.94	10000.27
Q_t_rc@POWER/0 [var]	440.1808	1888.968	1448.787	8440.327
Q_fund_SYM+rc@POWER/0 [var]	129.1428	1390.590	1261.447	2625.582

t1+60ms

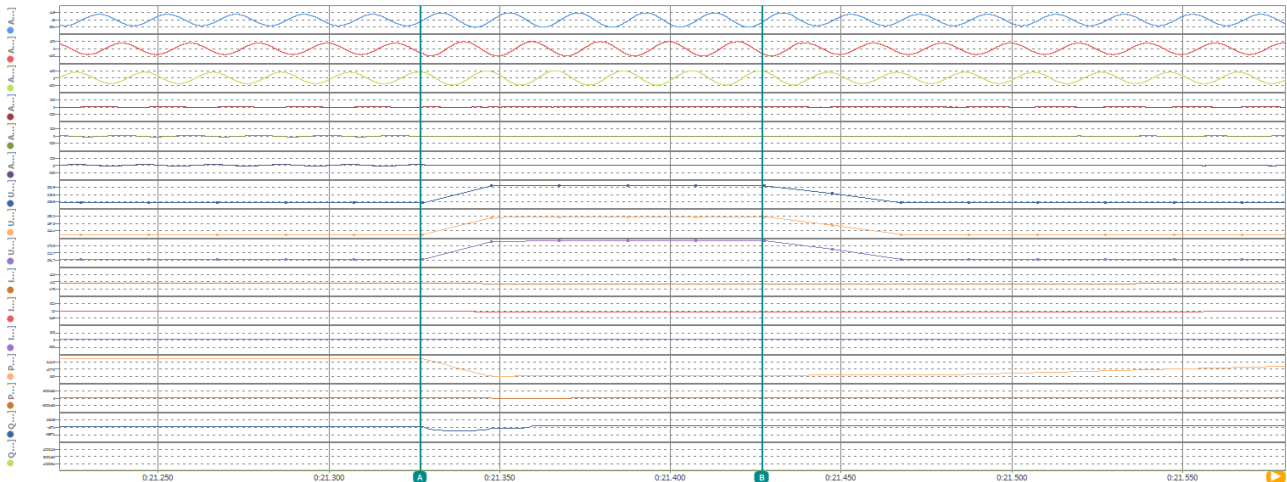

	A	B	Delta	RMS
Time [s]	0:21.326924	0:21.426930	0.100006	
AI 1/U1 [V]	-96.56406	-127.4140	-30.84994	287.0771
AI 1/U2 [V]	-220.9554	-270.5834	-49.62802	286.2738
AI 1/U3 [V]	317.2138	398.0773	80.86348	286.0451
AI 1/I1 [A]	-16.60482	-0.951325	15.65349	4.422596
AI 1/I2 [A]	-33.85249	1.161782	35.01427	5.977200
AI 1/I3 [A]	50.55834	-0.120276	-50.67861	6.631821
U1_IRMS@POWER/0 [V]	230.5300	287.4846	56.95464	269.5183
U2_IRMS@POWER/0 [V]	230.3827	287.3353	56.95253	269.2511
U3_IRMS@POWER/0 [V]	230.4029	287.3532	56.95029	269.2540
I1_IRMS@POWER/0 [A]	36.12157	2.301842	-33.81973	13.36145
I2_IRMS@POWER/0 [A]	36.25351	1.910592	-34.34292	12.79124
I3_IRMS@POWER/0 [A]	36.09959	1.878608	-34.22099	14.10737
P_t_rc@POWER/0 [W]	24992.78	102.7317	-24890.04	7449.812
P_fund_SYM+rc@POWER/0 [W]	24991.17	101.4756	-24889.69	7772.195
Q_t_rc@POWER/0 [var]	440.1808	1747.538	1307.357	6658.238
Q_fund_SYM+rc@POWER/0 [var]	129.1428	1409.197	1280.055	2216.587

t1+100ms



	A	B	Delta	RMS
Time [s]	0:21.675518	0:21.775518	0.248828	
AI 1/U1 [V]	163.3210	221.3748	58.0538	233.0532
AI 1/U2 [V]	-240.8571	100.8639	341.7211	233.3451
AI 1/U3 [V]	403.9617	-321.0464	-725.0081	232.8553
AI 1/I1 [A]	-0.951445	36.83504	37.78649	21.23929
AI 1/I2 [A]	1.556723	13.73109	12.17437	20.99709
AI 1/I3 [A]	-0.514678	-50.52292	-50.00794	20.86126
U1_IRMS@POWER/0 [V]	287.4846	230.5789	-56.90567	241.4798
U2_IRMS@POWER/0 [V]	287.3353	230.4302	-56.90508	241.3667
U3_IRMS@POWER/0 [V]	287.3532	230.4626	-56.89056	241.3562
I1_IRMS@POWER/0 [A]	2.301842	36.23737	33.93552	19.70471
I2_IRMS@POWER/0 [A]	1.910592	36.39622	34.48563	19.77111
I3_IRMS@POWER/0 [A]	1.878608	36.19825	34.31964	19.72184
P_t_rc@POWER/0 [W]	102.7317	25050.16	24947.43	13560.35
P_fund_SYM+rc@POWER/0 [W]	101.4756	25045.34	24943.86	13557.46
Q_t_rc@POWER/0 [var]	1747.538	1278.981	-468.5566	1496.216
Q_fund_SYM+rc@POWER/0 [var]	1409.197	96.13215	-1313.065	670.0699

Active power rising time

Condition						Measurement
No.	Parameter	Phase ref.	Time ref.	unit		
General Info.	0	Test number	--	--	--	5.3
	1	Date	--	--	dd.mm.yyyy	14.06.2025
	2	Time (start of test)	--	--	hh:mm:ss.f	10:41:26
	3	Fault type (phase)	--	--		D1
	4	Setting voltage depth	Line to line	--	p.u.	1.25
	5	Setting dip duration		--		100
	6	Point of fault entry	Total	--	ms	22261
	7	Point of fault clearance	Total	--	ms	22381
	8	Fault duration in empty load test	Total	--	ms	120
	9	Voltage depth/height in empty load test	Total	t1+100ms to t2 and t1-10s to t1	p.u.	1.251
10	Pos.		p.u.		1.000	
Before dip <t1	11	Voltage	Line to neutral	t1-100s to t1	p.u.	1.003
	12	Current	Pos.	t1-500ms to t1-100ms	p.u.	1.009
	13	Active power	Total	t1-10s to t1	p.u.	1.009
	14		Pos.			1.009
	15	Reactive power	Total	t1-10s to t1	p.u.	0.008
	16		Pos.			0.001
17	Cos ϕ	--	t1-10s to t1	--	0.999	
During dip t1 to t2	18	Voltage	Line to neutral	t1+100ms to t2-20ms	p.u.	1.248
	19	Line current	Phase 1	t1+60ms	p.u.	0.041
	20		Phase 2			0.024
	21		Phase 3			0.044
	22	Line current	Phase 1	t1+100ms	p.u.	0.036
	23		Phase 2			0.025
	24		Phase 3			0.028
	25	Active power	Total	t1+100ms to t2-20ms	p.u.	0.002
26	Pos.		0.002			
After dip > t2	27	Voltage	Line to neutral	t2+3s to t2+10s	p.u.	1.003
	28	Active power	Total	t2+3s to t2+10s	p.u.	1.008
	29		Pos.			1.008
	39	Active power rising time	Pos.	--	s	0.437
	31	Reactive power	Total	t2+3s to t2+10s	p.u.	0.008
	32		Pos.			0.001
	33	Reactive power rising time	Pos.	--	s	--
	34	PGU does not disconnect from grid till 60s after fault	--	t2 to t2+60s	Yes / No	Yes

Test No. 5.3 idle test

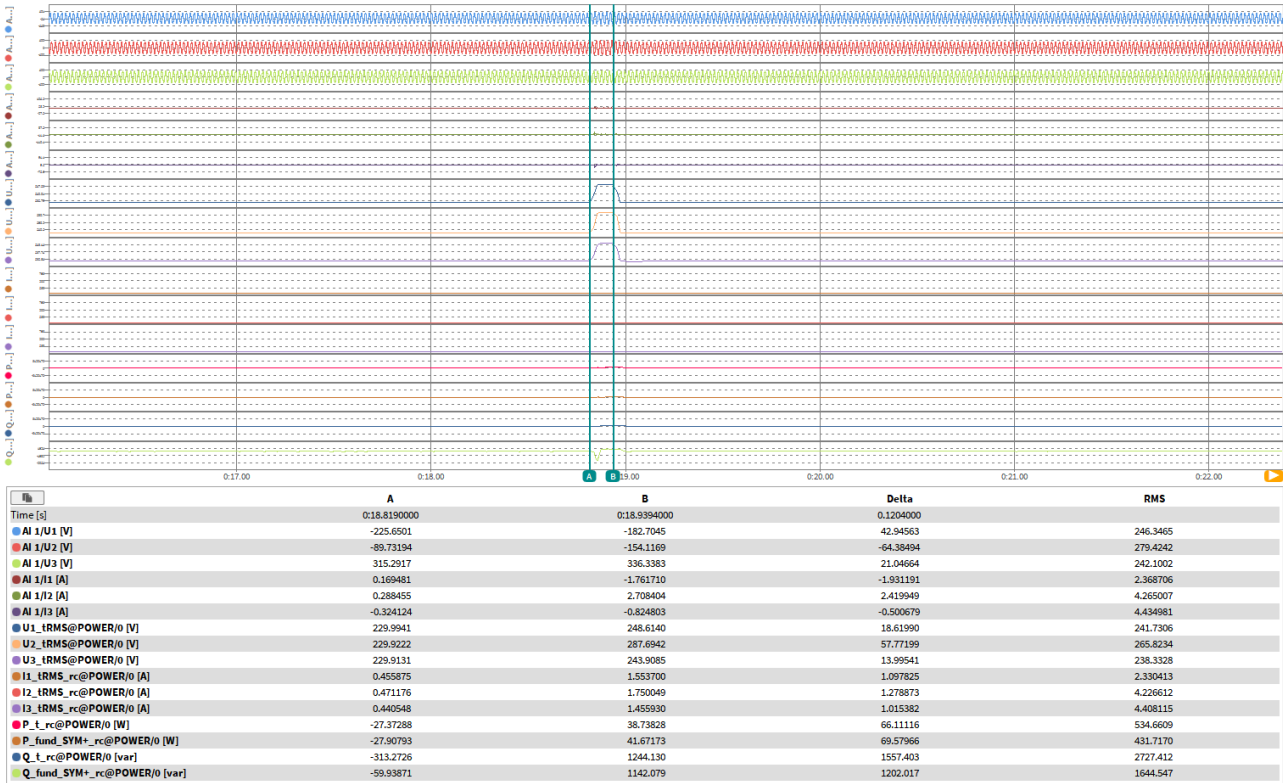

Test No. 5.3 with PGU

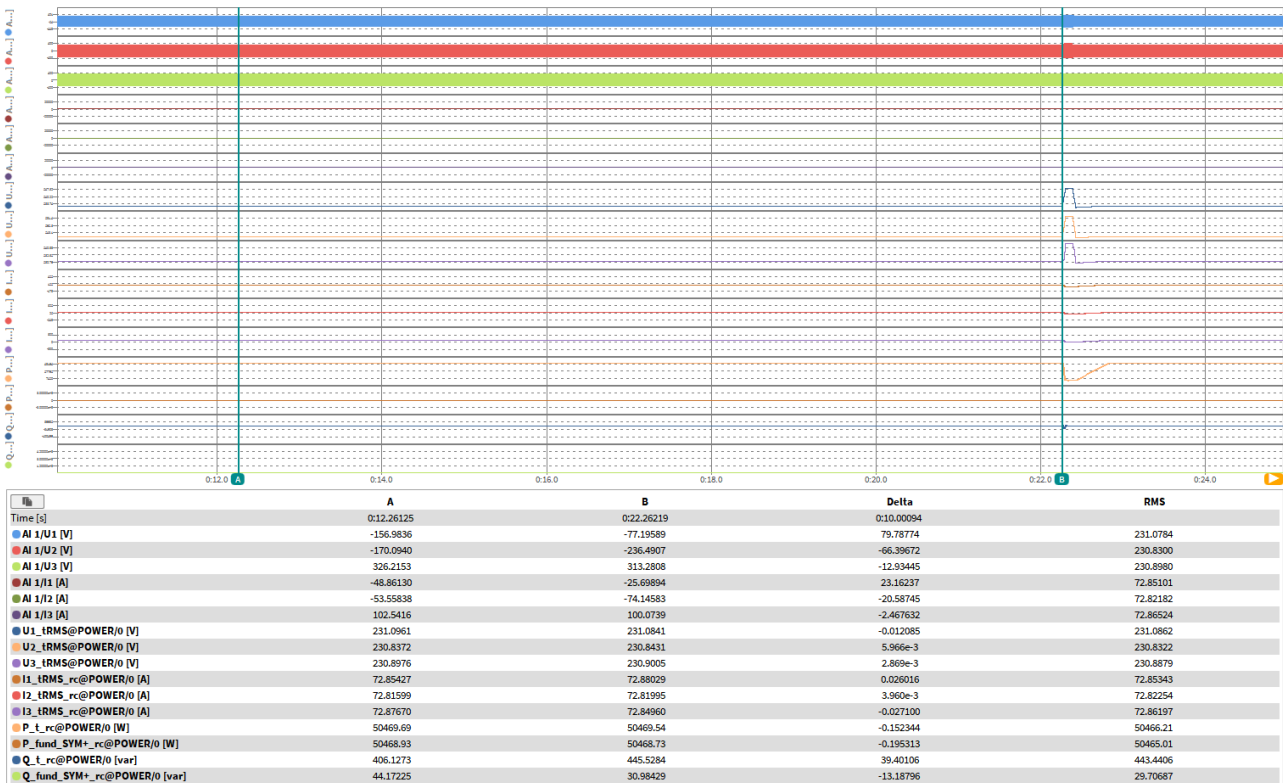

t1-10s to t1

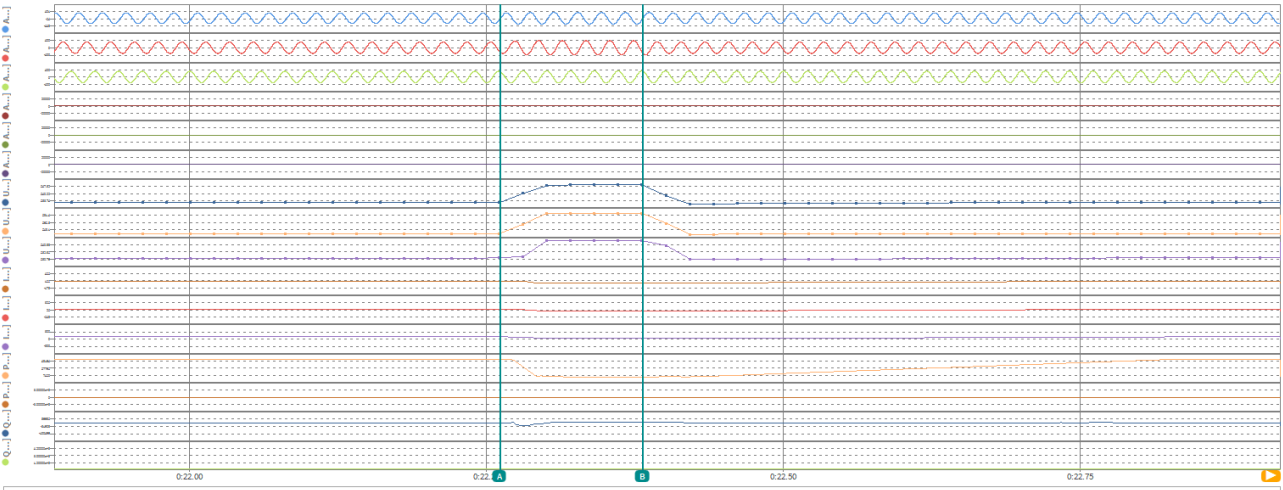

	A	B	Delta	RMS
Time [s]	0:22:26182	0:22:38218	0.12036	
AI 1/U1 [V]	-107.7945	-61.82361	45.97092	246.2709
AI 1/U2 [V]	-213.7733	-281.2689	-67.49559	282.0178
AI 1/U3 [V]	320.9186	341.3389	20.42031	241.8748
AI 1/I1 [A]	-34.67540	-3.311431	31.36397	22.15850
AI 1/I2 [A]	-67.12440	2.100436	69.22484	23.67358
AI 1/I3 [A]	102.0051	1.344806	-100.6603	23.89086
U1_IRMS@POWER/0 [V]	231.0841	248.2168	17.13272	242.1911
U2_IRMS@POWER/0 [V]	230.8431	287.2296	56.38651	267.9119
U3_IRMS@POWER/0 [V]	230.9005	243.5302	12.62973	238.3583
I1_IRMS_rc@POWER/0 [A]	72.88979	2.283563	-70.60622	31.91063
I2_IRMS_rc@POWER/0 [A]	72.81956	1.924830	-70.89473	31.22284
I3_IRMS_rc@POWER/0 [A]	72.87376	1.864939	-71.00882	32.82986
P_t_rc@POWER/0 [W]	50476.50	116.4426	-50360.06	20590.31
P_fund_SYM+rc@POWER/0 [W]	50475.59	115.3200	-50360.27	20793.19
Q_t_rc@POWER/0 [var]	448.3396	1569.627	1121.287	9370.818
Q_fund_SYM+rc@POWER/0 [var]	34.61699	1218.359	1183.742	2304.535

t1 to t2

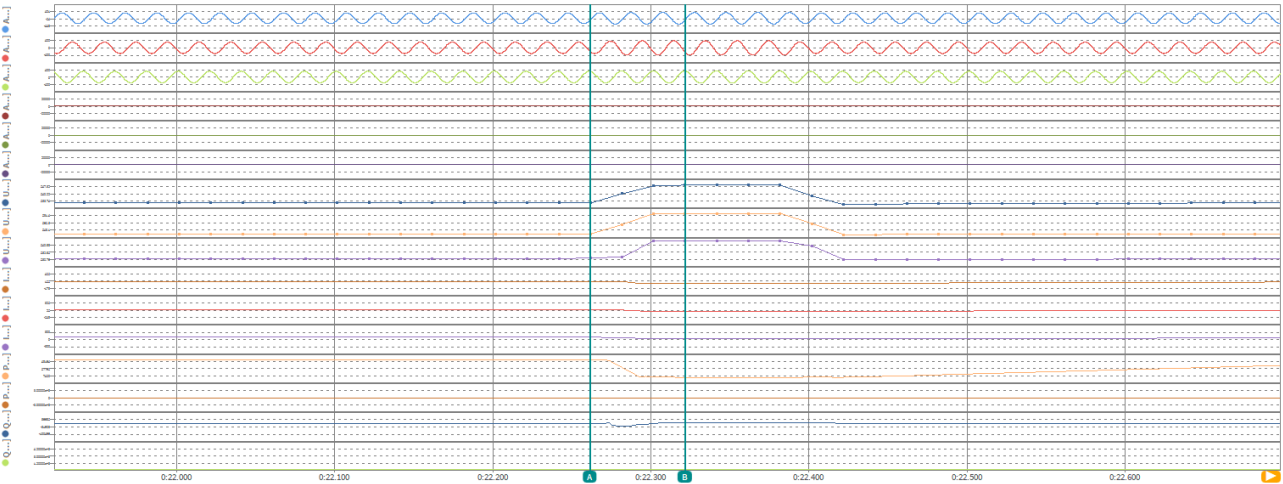

	A	B	Delta	RMS
Time [s]	0:22:26182	0:22:32193	0.06011	
AI 1/U1 [V]	-107.7945	-83.71974	24.07479	244.6988
AI 1/U2 [V]	-213.7733	-261.4877	-47.71447	276.7626
AI 1/U3 [V]	320.9186	343.4847	22.56608	239.8165
AI 1/I1 [A]	-34.67540	-3.979003	30.69639	31.23287
AI 1/I2 [A]	-67.12440	1.337497	68.46190	33.42586
AI 1/I3 [A]	102.0051	2.751476	-99.25366	33.72630
U1_IRMS@POWER/0 [V]	231.0841	247.9631	16.87907	237.5564
U2_IRMS@POWER/0 [V]	230.8431	286.6248	55.78165	252.5126
U3_IRMS@POWER/0 [V]	230.9005	243.5036	12.60310	234.3954
I1_IRMS_rc@POWER/0 [A]	72.88979	3.029999	-69.86379	45.05352
I2_IRMS_rc@POWER/0 [A]	72.81956	1.741677	-71.07789	44.11775
I3_IRMS_rc@POWER/0 [A]	72.87376	3.209482	-69.66528	46.37741
P_t_rc@POWER/0 [W]	50476.50	413.6246	-50062.88	29118.77
P_fund_SYM+rc@POWER/0 [W]	50475.59	409.1125	-50066.48	29405.67
Q_t_rc@POWER/0 [var]	448.3396	1950.662	1502.322	13143.80
Q_fund_SYM+rc@POWER/0 [var]	34.61699	1476.138	1441.521	3009.174

t1+60ms

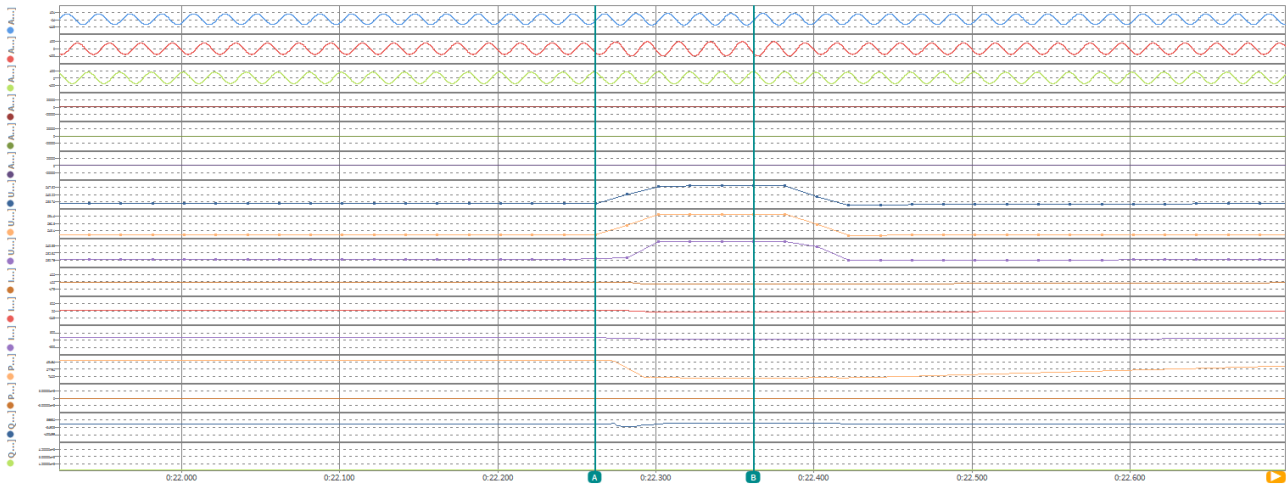

	A	B	Delta	RMS
Time [s]	0:22:26182	0:22:36195	0,10013	
AI 1/U1 [V]	-107,7945	-83,47774	24,31679	246,1064
AI 1/U2 [V]	-213,7733	-262,0101	-48,23685	280,9730
AI 1/U3 [V]	320,9186	343,8788	22,96019	241,2962
AI 1/I1 [A]	-34,67540	-4,110133	30,56526	24,26767
AI 1/I2 [A]	-67,12440	2,505748	69,63015	25,93591
AI 1/I3 [A]	102,0051	1,714355	-100,2908	26,17522
U1_IRMS@POWER/0 [V]	231,0841	248,2117	17,12761	241,1721
U2_IRMS@POWER/0 [V]	230,8431	287,1857	56,34253	264,5552
U3_IRMS@POWER/0 [V]	230,9005	243,5084	12,60789	237,4853
I1_IRMS@POWER/0 [A]	72,88979	2,623389	-70,26640	35,05393
I2_IRMS@POWER/0 [A]	72,81956	1,863327	-70,95624	34,30481
I3_IRMS@POWER/0 [A]	72,87376	2,077128	-70,79664	36,07135
P_t_rc@POWER/0 [W]	50476,50	115,3144	-50361,19	22629,78
P_fund_SYM+rc@POWER/0 [W]	50475,59	120,4118	-50355,18	22852,76
Q_t_rc@POWER/0 [var]	448,3396	1688,242	1239,903	10273,02
Q_fund_SYM+rc@POWER/0 [var]	34,61699	1218,610	1183,993	2474,121

t1+100ms



	A	B	Delta	RMS
Time [s]	0:22:38142	0:22:81931	0,43789	
AI 1/U1 [V]	-135,8309	-290,8728	-155,0419	230,9172
AI 1/U2 [V]	-209,3542	15,93065	225,2848	232,3337
AI 1/U3 [V]	343,4272	270,7529	-72,67428	230,5056
AI 1/I1 [A]	-3,635952	-88,58184	-84,94589	41,71616
AI 1/I2 [A]	3,769366	0,467269	-3,302098	41,55995
AI 1/I3 [A]	0,188476	88,27223	88,08375	41,31638
U1_IRMS@POWER/0 [V]	248,2168	231,1995	-17,01729	232,4306
U2_IRMS@POWER/0 [V]	287,2296	230,9474	-56,28220	237,1460
U3_IRMS@POWER/0 [V]	243,5302	231,0039	-12,52632	231,9646
I1_IRMS@POWER/0 [A]	2,335313	72,40652	70,07120	40,01967
I2_IRMS@POWER/0 [A]	1,920754	72,36307	70,44231	40,01145
I3_IRMS@POWER/0 [A]	1,876480	72,16913	70,29265	40,01422
P_t_rc@POWER/0 [W]	131,7111	50101,95	49970,24	27674,17
P_fund_SYM+rc@POWER/0 [W]	132,5862	50095,14	49962,55	27670,57
Q_t_rc@POWER/0 [var]	1582,947	-1563,169	-3146,116	1320,601
Q_fund_SYM+rc@POWER/0 [var]	1227,615	-70,46420	-1298,079	355,2605

Active power rising time

Condition						Measurement
No.	Parameter	Phase ref.	Time ref.	unit		
General Info.	0	Test number	--	--	--	5.3(D2)
	1	Date	--	--	dd.mm.yyyy	26.06.2025
	2	Time (start of test)	--	--	hh:mm:ss.f	15:12:49
	3	Fault type (phase)	--	--		D2
	4	Setting voltage depth	Line to line	--	p.u.	1.25
	5	Setting dip duration		--		100
	6	Point of fault entry	Total	--	ms	20784
	7	Point of fault clearance	Total	--	ms	20904
	8	Fault duration in empty load test	Total	--	ms	123
	9	Voltage depth/height in empty load test	Total	t1+100ms to t2 and t1-10s to t1	p.u.	1.250
10	Pos.		p.u.		1.000	
Before dip <t1	11	Voltage	Line to neutral	t1-100s to t1	p.u.	1.004
	12	Current	Pos.	t1-500ms to t1-100ms	p.u.	1.011
	13	Active power	Total	t1-10s to t1	p.u.	1.009
	14		Pos.			1.009
	15	Reactive power	Total	t1-10s to t1	p.u.	0.011
	16		Pos.			0.007
17	Cos ϕ	--	t1-10s to t1	--	0.999	
During dip t1 to t2	18	Voltage	Line to neutral	t1+100ms to t2-20ms	p.u.	1.248
	19	Line current	Phase 1	t1+60ms	p.u.	0.113
	20		Phase 2			0.055
	21		Phase 3			0.086
	22	Line current	Phase 1	t1+100ms	p.u.	0.027
	23		Phase 2			0.024
	24		Phase 3			0.027
	25	Active power	Total	t1+100ms to t2-20ms	p.u.	0.002
26	Pos.		0.001			
After dip > t2	27	Voltage	Line to neutral	t2+3s to t2+10s	p.u.	1.004
	28	Active power	Total	t2+3s to t2+10s	p.u.	1.009
	29		Pos.			1.009
	39	Active power rising time	Pos.	--	s	0.475
	31	Reactive power	Total	t2+3s to t2+10s	p.u.	0.019
	32		Pos.			0.007
	33	Reactive power rising time	Pos.	--	s	--
	34	PGU does not disconnect from grid till 60s after fault	--	t2 to t2+60s	Yes / No	Yes

Test No. 5.3(D2) idle test

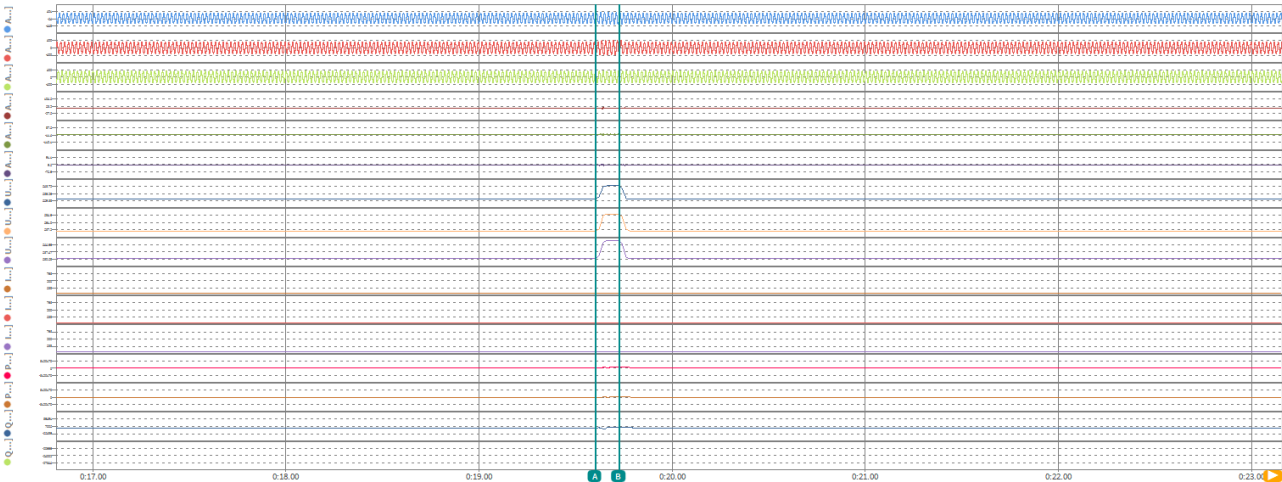

	A	B	Delta	RMS
Time [s]	0:19.602400	0:19.726300	0.123900	
AI 1/U1 [V]	-319.1312	-212.2059	106.9253	243.3968
AI 1/U2 [V]	216.9609	-227.3529	-444.3138	273.5614
AI 1/U3 [V]	101.5120	351.7096	250.1977	245.2450
AI 1/I1 [A]	-0.271594	-2.047812	-1.776219	3.157358
AI 1/I2 [A]	0.419585	2.863376	2.443791	3.734199
AI 1/I3 [A]	-0.026101	-0.681752	-0.655651	3.624353
U1_IRMS@POWER0 [V]	229.9955	243.9853	13.98985	238.2295
U2_IRMS@POWER0 [V]	229.9264	287.6797	57.75331	264.4070
U3_IRMS@POWER0 [V]	229.9207	248.5653	18.64465	240.8594
I1_IRMS_rc@POWER0 [A]	0.454175	1.495262	1.041087	3.122858
I2_IRMS_rc@POWER0 [A]	0.457525	1.726558	1.269033	2.669502
I3_IRMS_rc@POWER0 [A]	0.442325	1.678180	1.235855	3.574405
P_t_rc@POWER0 [W]	-19.14627	104.3855	123.5318	368.2918
P_fund_SYM+rc@POWER0 [W]	-19.67136	105.4148	125.0862	348.5428
Q_t_rc@POWER0 [var]	-310.7692	1274.287	1585.056	2347.368
Q_fund_SYM+rc@POWER0 [var]	-39.69028	1135.156	1174.847	1515.898

Test No. 5.3(D2) with PGU



	A	B	Delta	RMS
Time [s]	0:10.71590	0:20.79200	0:10.07610	
AI 1/U1 [V]	254.3430	-207.5708	-461.9139	231.1918
AI 1/U2 [V]	53.80702	-116.0195	-169.8265	230.8932
AI 1/U3 [V]	-305.5551	321.9686	627.5237	230.9931
AI 1/I1 [A]	80.75497	-65.22874	-145.9837	72.66774
AI 1/I2 [A]	15.89295	-35.89157	-51.78452	73.06267
AI 1/I3 [A]	-96.56179	101.2941	197.8159	72.76346
U1_IRMS@POWER0 [V]	231.5028	231.1816	-0.020971	231.1917
U2_IRMS@POWER0 [V]	230.9984	230.9022	-3.326e-3	230.9005
U3_IRMS@POWER0 [V]	230.9804	230.9872	6.790e-3	230.9858
I1_IRMS_rc@POWER0 [A]	72.66629	72.67126	4.974e-3	72.66781
I2_IRMS_rc@POWER0 [A]	73.06608	73.06631	2.289e-4	73.06489
I3_IRMS_rc@POWER0 [A]	72.74619	72.75198	5.783e-3	72.76123
P_t_rc@POWER0 [W]	50471.19	50474.76	3.566496	50474.58
P_fund_SYM+rc@POWER0 [W]	50469.71	50473.23	3.523438	50473.08
Q_t_rc@POWER0 [var]	563.1905	582.8909	19.70044	565.3529
Q_fund_SYM+rc@POWER0 [var]	379.3762	411.8240	32.44781	382.8639

t1-10s to t1

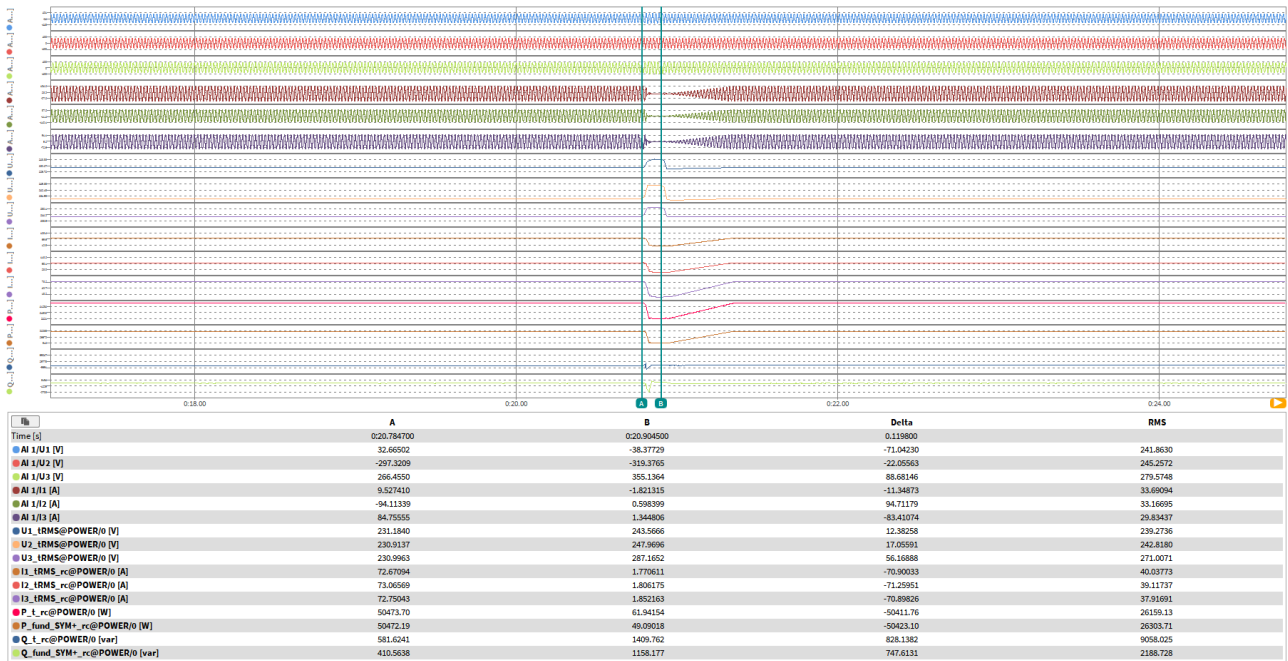

t1 to t2

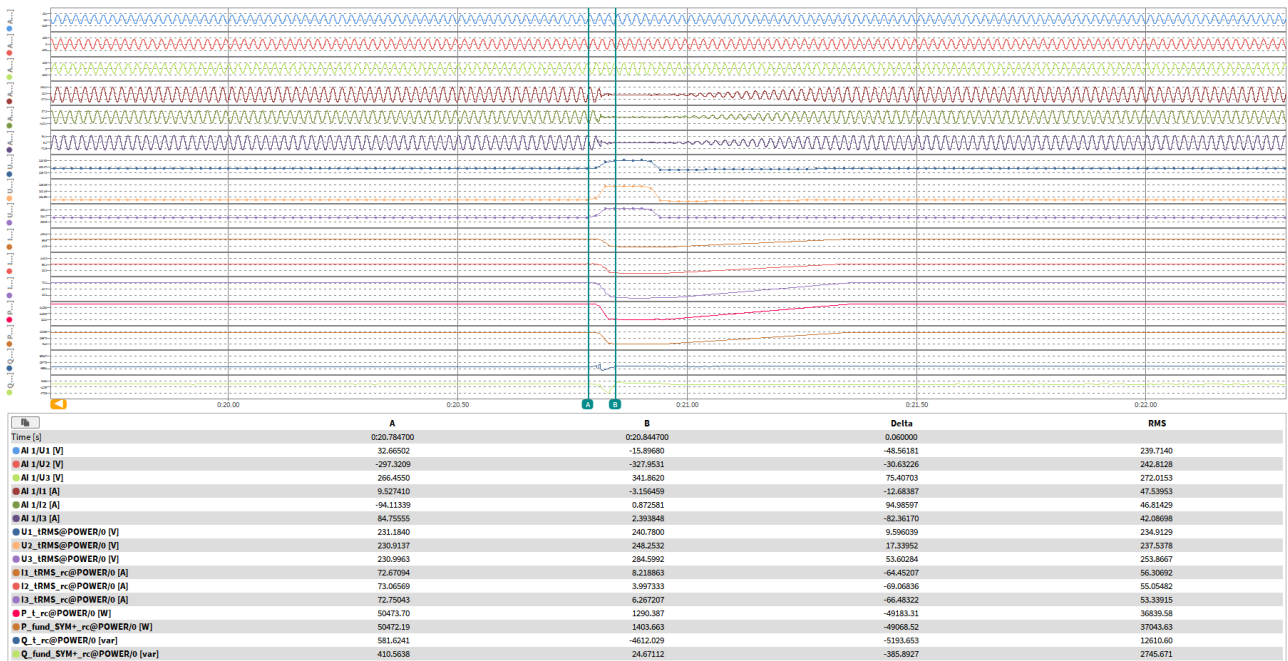

t1+60ms

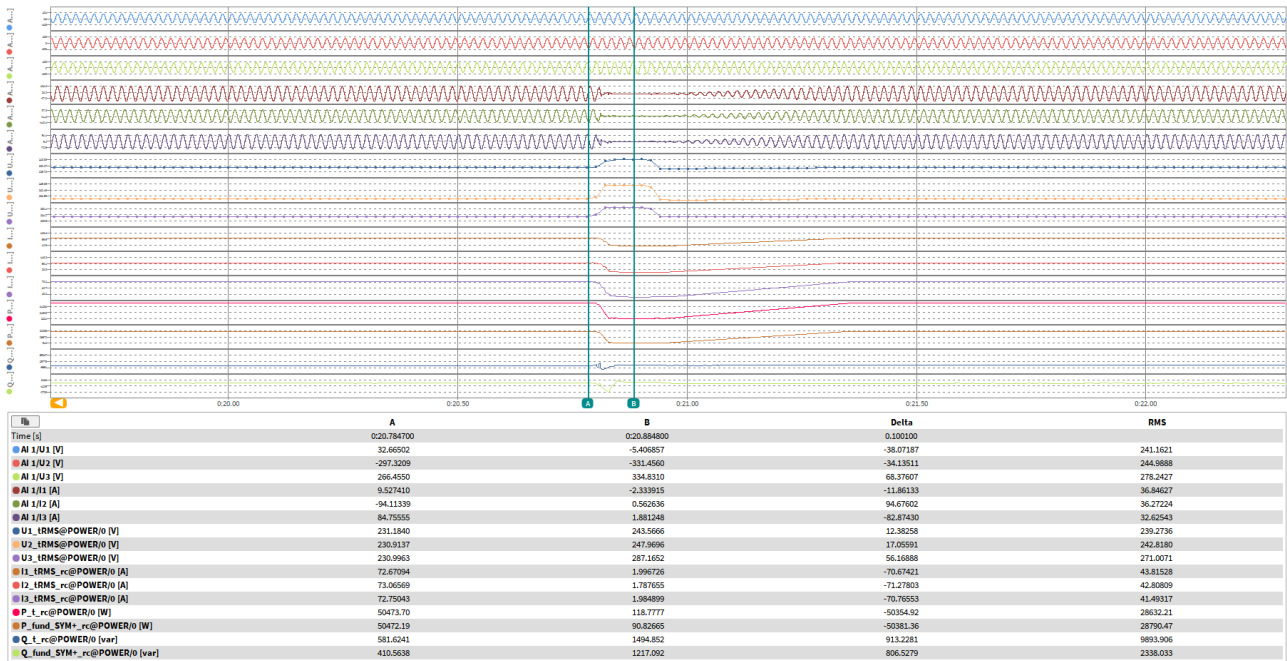

t1+100ms

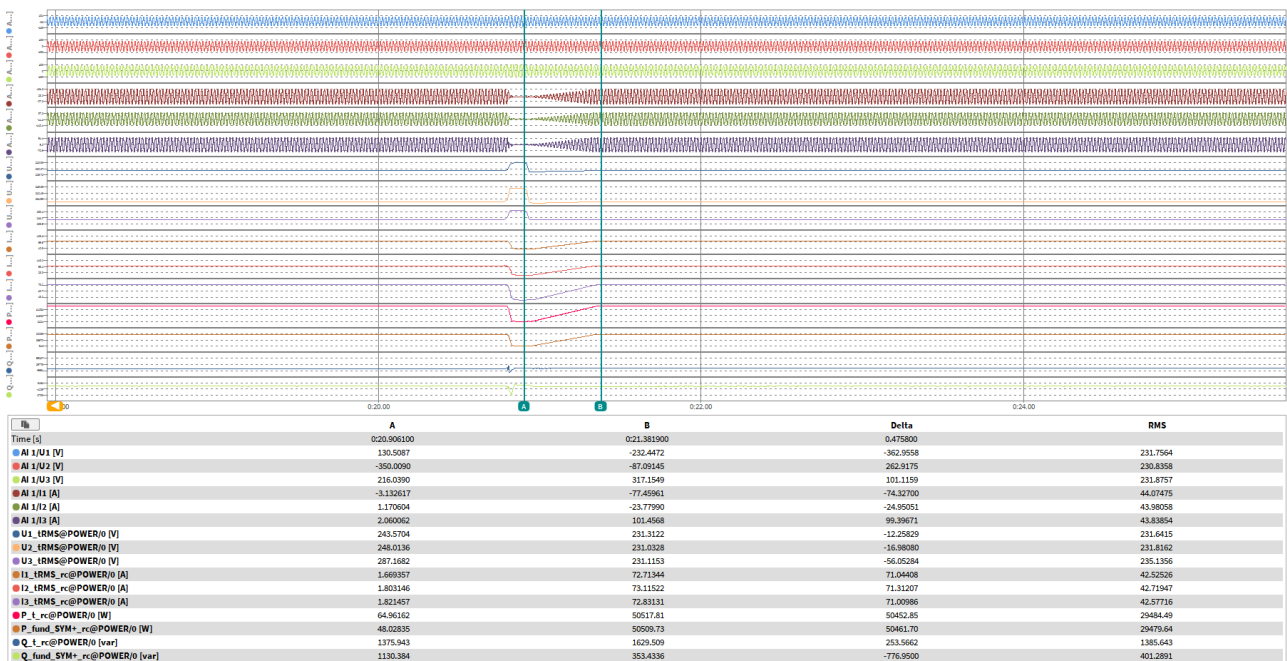

Active power rising time

Condition						Measurement
	No.	Parameter	Phase ref.	Time ref.	unit	
General Info.	0	Test number	--	--	--	5.4
	1	Date	--	--	dd.mm.yyyy	14.06.2025
	2	Time (start of test)	--	--	hh:mm:ss.f	10:39:12
	3	Fault type (phase)	--	--		D1
	4	Setting voltage depth	Line to line	--		1.25
	5	Setting dip duration		--		100
	6	Point of fault entry	Total	--		18301
	7	Point of fault clearance	Total	--		18421
	8	Fault duration in empty load test	Total	--		120
	9	Voltage depth/height in empty load test	Total	t1+100ms to t2 and t1-10s to t1	p.u.	1.251
10	Pos.		p.u.		1.000	
Before dip <t1	11	Voltage	Line to neutral	t1-100s to t1	p.u.	1.002
	12	Current	Pos.	t1-500ms to t1-100ms	p.u.	0.500
	13	Active power	Total	t1-10s to t1	p.u.	0.499
	14		Pos.			0.499
	15	Reactive power	Total	t1-10s to t1	p.u.	0.007
	16		Pos.			0.001
	17	Cos ϕ	--	t1-10s to t1	--	0.999
During dip t1 to t2	18	Voltage	Line to neutral	t1+100ms to t2-20ms	p.u.	1.248
	19	Line current	Phase 1	t1+60ms	p.u.	0.039
	20		Phase 2			0.057
	21		Phase 3			0.061
	22	Line current	Phase 1	t1+100ms	p.u.	0.020
	23		Phase 2			0.028
	24		Phase 3			0.023
	25	Active power	Total	t1+100ms to t2-20ms	p.u.	0.003
	26		Pos.			0.002
After dip > t2	27	Voltage	Line to neutral	t2+3s to t2+10s	p.u.	1.002
	28	Active power	Total	t2+3s to t2+10s	p.u.	0.499
	29		Pos.			0.499
	30	Active power rising time	Pos.	--	s	0.246
	31	Reactive power	Total	t2+3s to t2+10s	p.u.	0.008
	32		Pos.			0.001
	33	Reactive power rising time	Pos.	--	s	--
	34	PGU does not disconnect from grid till 60s after fault	--	t2 to t2+60s	Yes / No	Yes

Test No. 5.4 idle test

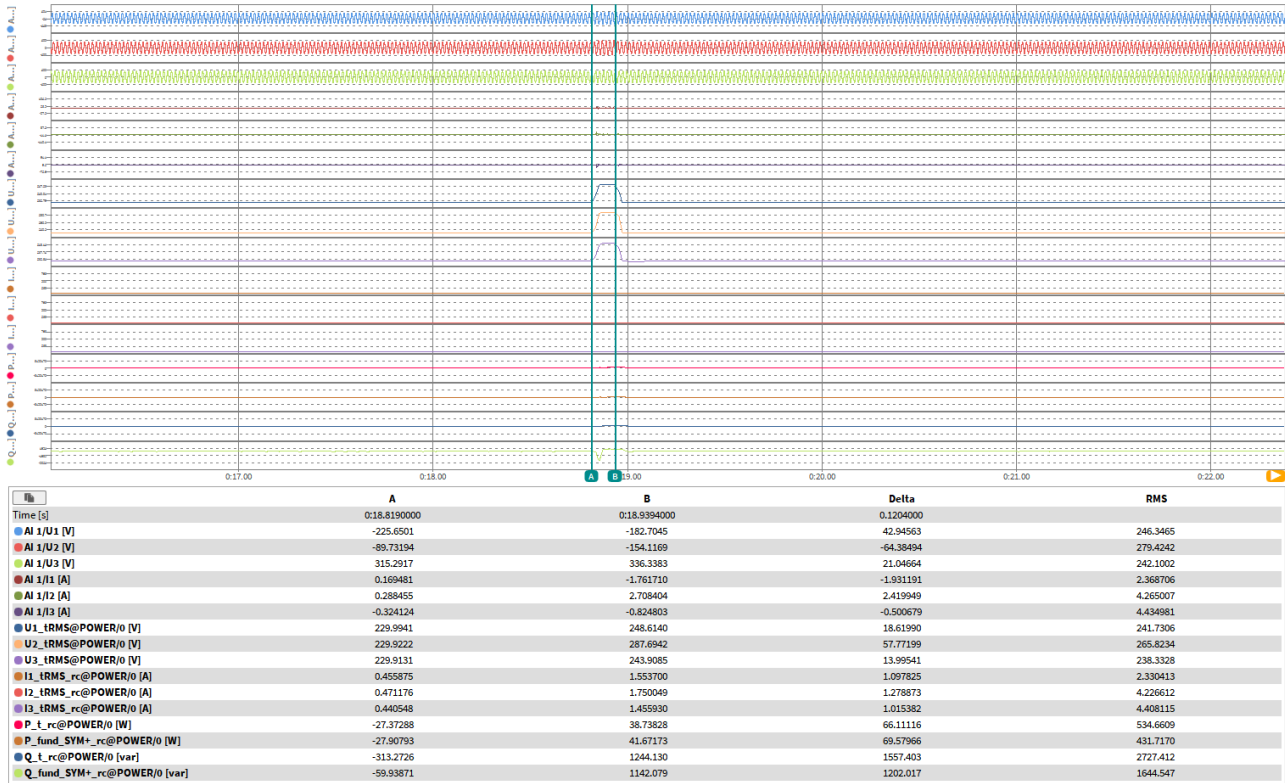

Test No. 5.4 with PGU

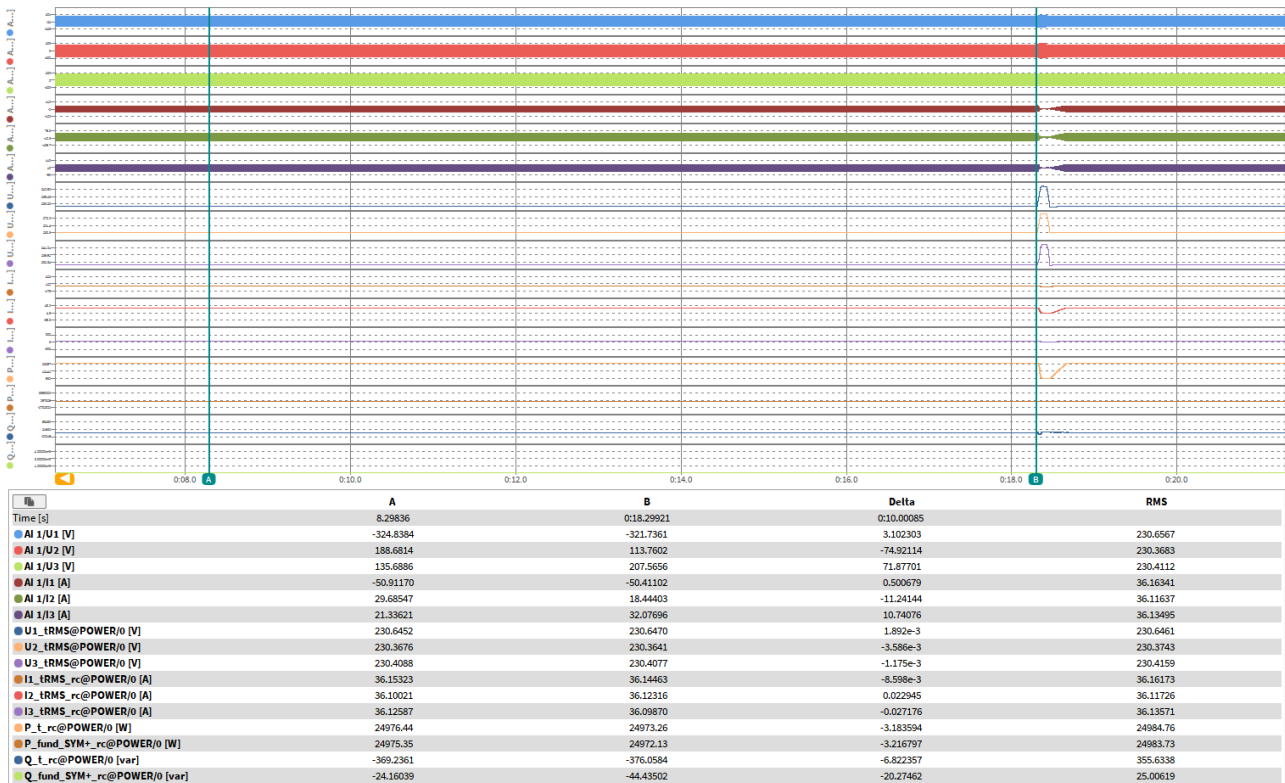

t1-10s to t1

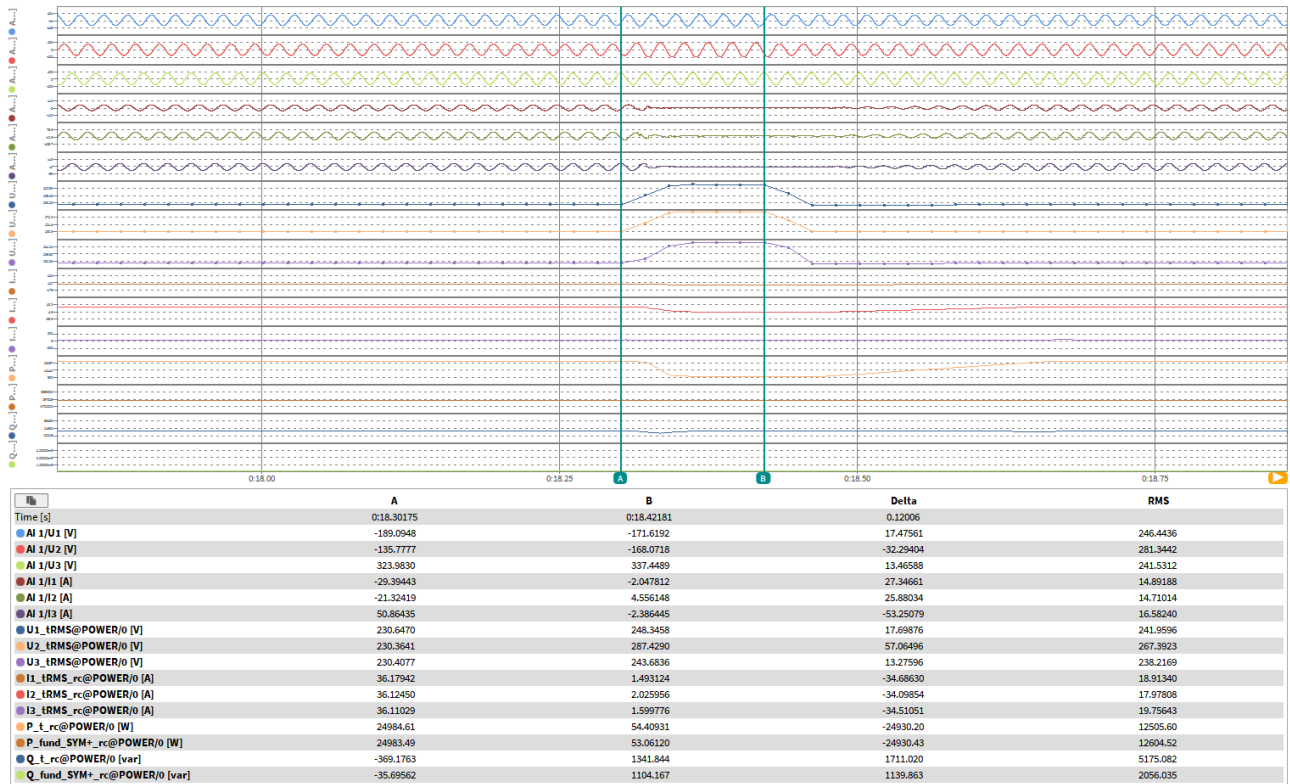

t1 to t2

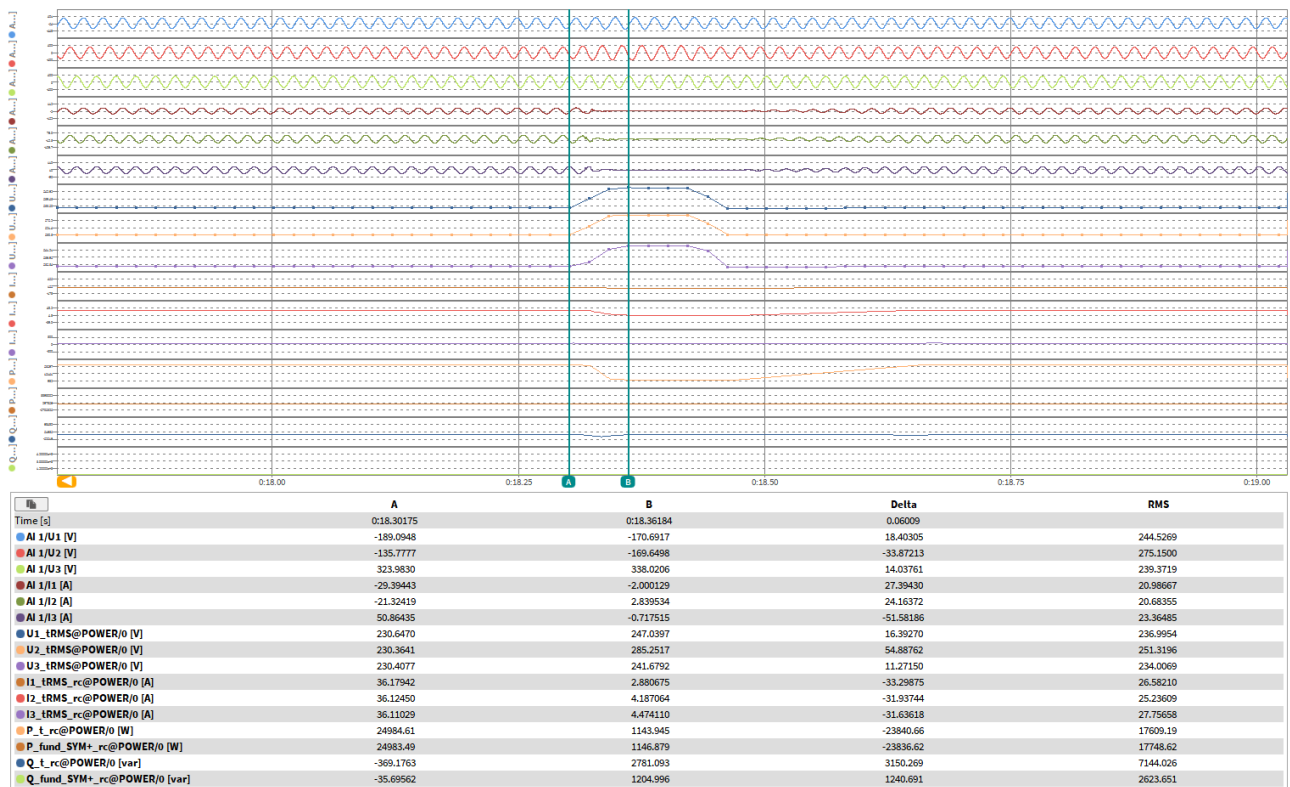

t1+60ms

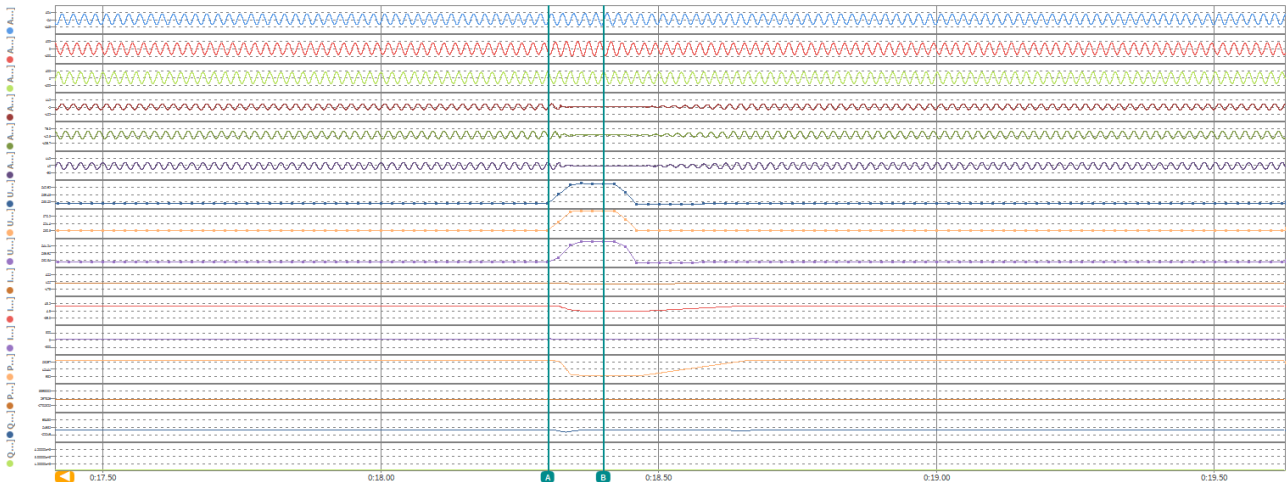

	A	B	Delta	RMS
Time [s]	0:18.30175	0:18.40194	0.10020	
AI 1/U1 [V]	-189.0948	-161.5670	27.52781	245.9907
AI 1/U2 [V]	-135.7777	-180.0144	-44.23666	280.0341
AI 1/U3 [V]	323.9830	339.2670	15.28406	241.2184
AI 1/I1 [A]	-29.39443	-1.892840	27.50158	16.28877
AI 1/I2 [A]	-21.32419	4.639594	25.96378	16.07871
AI 1/I3 [A]	50.86435	-2.648705	-53.51305	18.19932
U1_IRMS@POWER/0 [V]	230.6470	248.3528	17.70572	240.8788
U2_IRMS@POWER/0 [V]	230.3641	287.4552	57.09114	263.9050
U3_IRMS@POWER/0 [V]	230.4077	243.7214	13.31372	237.2935
I1_IRMS@POWER/0 [A]	36.17942	1.502492	-34.67693	20.69068
I2_IRMS@POWER/0 [A]	36.12450	2.069506	-34.05499	19.65573
I3_IRMS@POWER/0 [A]	36.11029	1.722823	-34.38746	21.61096
P_t_rc@POWER/0 [W]	24984.61	153.8510	-24830.75	13687.82
P_fund_SYM+_rc@POWER/0 [W]	24983.49	146.8921	-24836.60	13796.10
Q_t_rc@POWER/0 [var]	-369.1763	1379.244	1748.420	5630.682
Q_fund_SYM+_rc@POWER/0 [var]	-35.69562	1144.982	1180.677	2192.662

t1+100ms

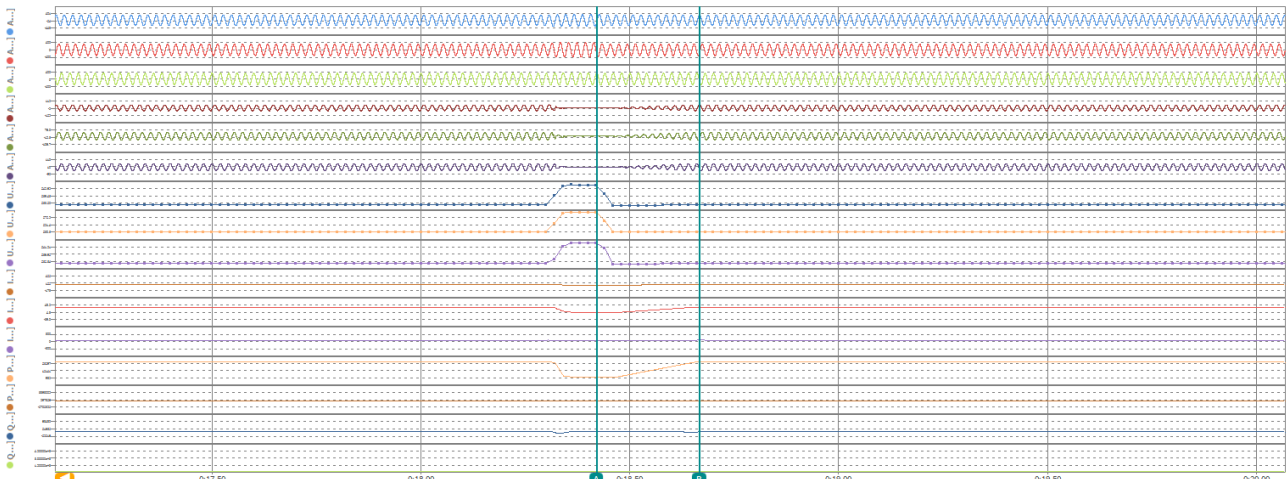

	A	B	Delta	RMS
Time [s]	0:18.42181	0:18.66805	0.24624	
AI 1/U1 [V]	-171.6192	319.6380	491.2572	230.3108
AI 1/U2 [V]	-168.0718	-218.9319	-50.86017	234.6775
AI 1/U3 [V]	337.4489	-102.0639	-439.5128	230.8998
AI 1/I1 [A]	-2.047812	50.20162	52.24943	20.86263
AI 1/I2 [A]	4.556146	-35.92773	-40.48348	21.25511
AI 1/I3 [A]	-2.386445	-34.12856	-31.74211	20.81211
U1_IRMS@POWER/0 [V]	248.3458	230.7176	-17.62822	233.7477
U2_IRMS@POWER/0 [V]	287.4290	230.4281	-57.00093	241.6609
U3_IRMS@POWER/0 [V]	243.6836	230.4716	-13.21178	232.9182
I1_IRMS@POWER/0 [A]	1.493124	36.30212	34.80900	19.70284
I2_IRMS@POWER/0 [A]	2.029596	36.38103	34.35508	19.74350
I3_IRMS@POWER/0 [A]	1.599776	36.39342	34.79365	19.70518
P_t_rc@POWER/0 [W]	54.40931	25122.65	25068.24	13572.20
P_fund_SYM+_rc@POWER/0 [W]	53.06120	25119.29	25066.23	13570.13
Q_t_rc@POWER/0 [var]	1341.844	1073.341	-268.5028	1248.295
Q_fund_SYM+_rc@POWER/0 [var]	1104.167	3.775378	-1100.392	559.4079

Active power rising time

Condition						Measurement	
	No.	Parameter	Phase ref.	Time ref.	unit		
General Info.	0	Test number	--	--	--	6.1	
	1	Date	--	--	dd.mm.yyyy	15.05.2025	
	2	Time (start of test)	--	--	hh:mm:ss.f	10:30:50	
	3	Fault type (phase)	--	--		A	
	4	Setting voltage depth	Line to line	--		1.2	
	5	Setting dip duration		--		5000	
	6	Point of fault entry	Total	--		ms	
	7	Point of fault clearance	Total	--		ms	
	8	Fault duration in empty load test	Total	--		ms	
	9	Voltage depth/height in empty load test	Total	t1+100ms to t2 and t1-10s to t1		p.u.	1.200
10	Pos.				p.u.	1.000	
Before dip <t1	11	Voltage	Line to neutral	t1-100s to t1		p.u.	1.003
	12	Current	Pos.	t1-500ms to t1-100ms		p.u.	1.009
	13	Active power	Total	t1-10s to t1		p.u.	1.009
	14		Pos.			p.u.	1.009
	15	Reactive power	Total	t1-10s to t1		p.u.	0.013
	16		Pos.			p.u.	0.008
17	Cosφ	--	t1-10s to t1		--	0.999	
During dip t1 to t2	18	Voltage	Line to neutral	t1+100ms to t2-20ms		p.u.	1.197
	19	Line current	Phase 1	t1+60ms		p.u.	0.078
	20		Phase 2			p.u.	0.059
	21		Phase 3			p.u.	0.099
	22	Line current	Phase 1	t1+100ms		p.u.	0.048
	23		Phase 2			p.u.	0.030
	24		Phase 3			p.u.	0.042
	25	Active power	Total	t1+100ms to t2-20ms		p.u.	0.001
26	Pos.				p.u.	0.001	
After dip > t2	27	Voltage	Line to neutral	t2+3s to t2+10s		p.u.	1.004
	28	Active power	Total	t2+3s to t2+10s		p.u.	1.003
	29		Pos.			p.u.	1.003
	39	Active power rising time	Pos.	--		s	0.435
	31	Reactive power	Total	t2+3s to t2+10s		p.u.	0.037
	32		Pos.			p.u.	0.004
	33	Reactive power rising time	Pos.	--		s	--
	34	PGU does not disconnect from grid till 60s after fault	--	t2 to t2+60s		Yes / No	Yes

Test No. 6.1 idle test

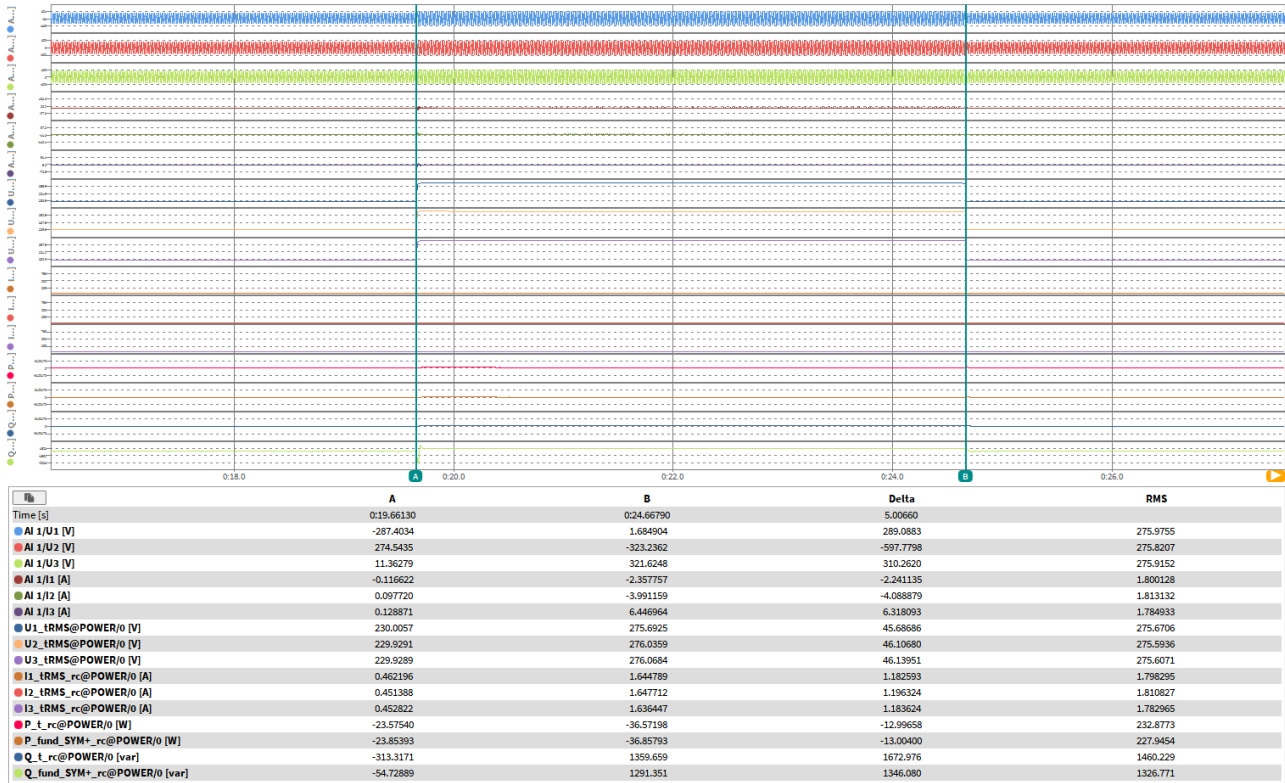

Test No. 6.1 with PGU

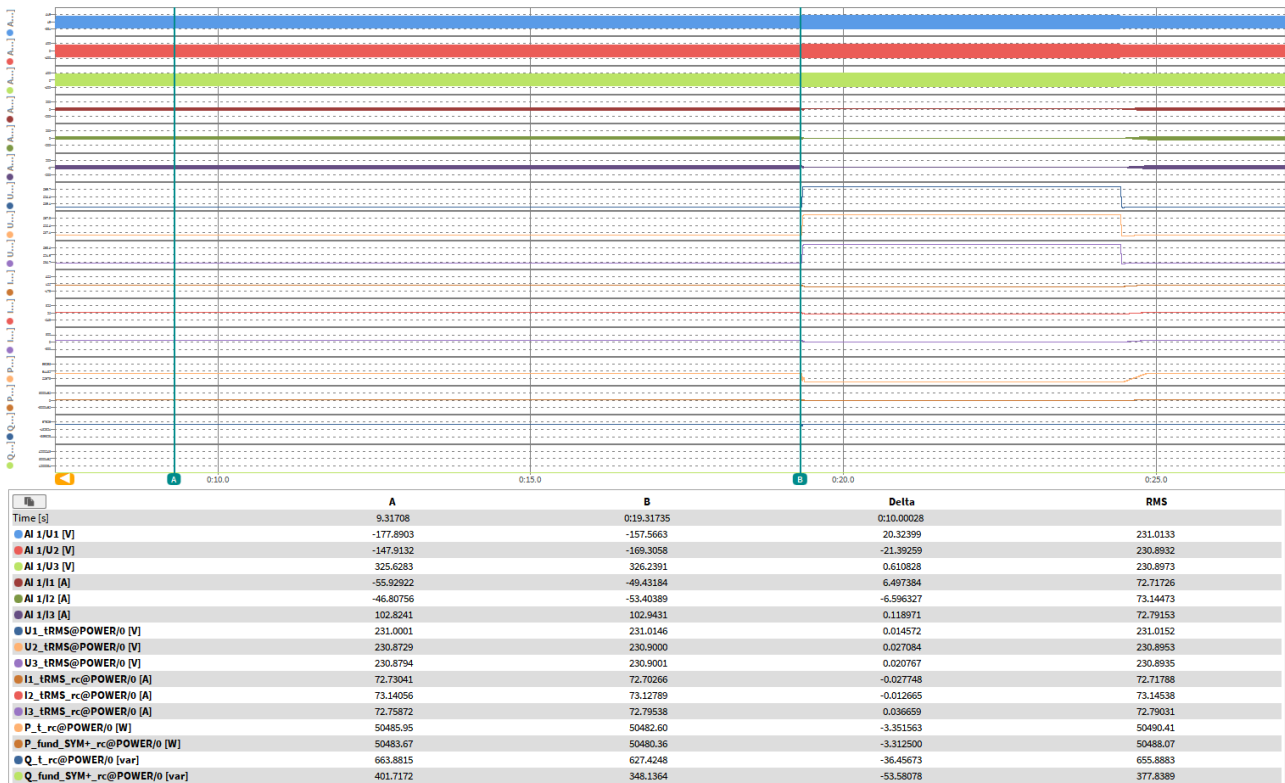

t1-10s to t1

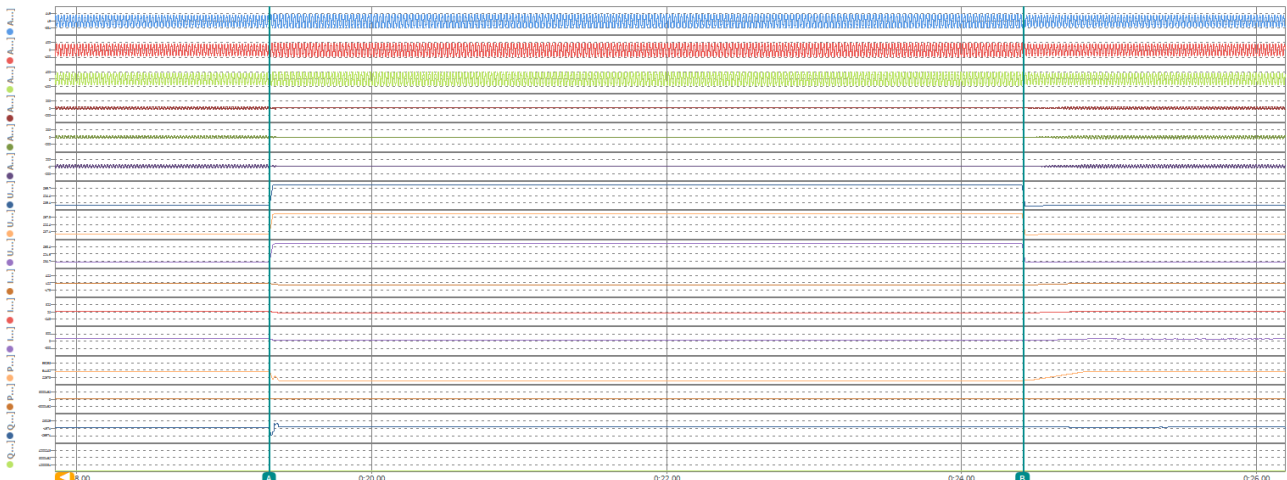

	A	B	Delta	RMS
Time [s]	0:19.31297	0:24.41764	5.10468	
AI 1/U1 [V]	-310.3843	-170.5482	139.8361	275.9625
AI 1/U2 [V]	242.1727	-218.4575	-460.6302	275.7729
AI 1/U3 [V]	70.06813	369.0712	319.0031	275.8564
AI 1/I1 [A]	-97.00279	-2.405917	94.59687	4.084437
AI 1/I2 [A]	77.68235	2.335159	-75.34719	3.497149
AI 1/I3 [A]	19.41109	0.160700	-19.25039	4.132421
U1_IRMS@POWER/0 [V]	231.0146	275.9922	44.97757	275.6565
U2_IRMS@POWER/0 [V]	230.9000	275.8987	44.99872	275.5574
U3_IRMS@POWER/0 [V]	230.9001	275.9225	45.02235	275.5742
I1_IRMS@POWER/0 [A]	72.71198	1.671489	-71.04049	5.246189
I2_IRMS@POWER/0 [A]	73.13728	1.670054	-71.46722	5.086939
I3_IRMS@POWER/0 [A]	72.80503	1.668219	-71.13681	5.323209
P_t_rc@POWER/0 [W]	50489.05	40.17443	-50448.88	3152.039
P_fund_SYM+rc@POWER/0 [W]	50486.83	39.49075	-50447.34	3196.607
Q_t_rc@POWER/0 [var]	628.3224	1381.818	753.4957	2339.885
Q_fund_SYM+rc@POWER/0 [var]	350.0948	1291.522	941.4273	1306.984

t1 to t2

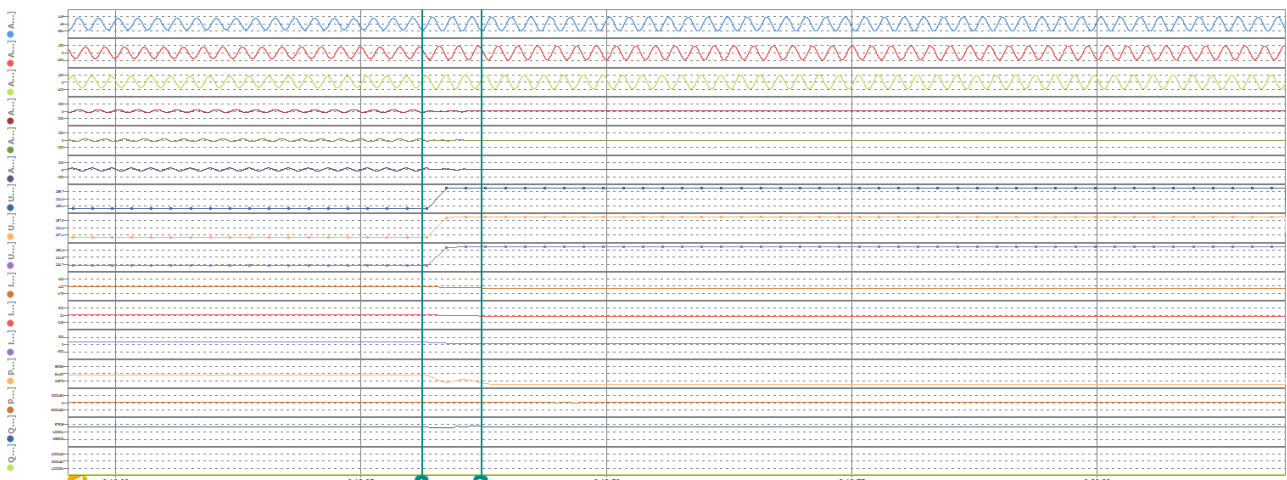

	A	B	Delta	RMS
Time [s]	0:19.31297	0:19.37301	0.06004	
AI 1/U1 [V]	-310.3843	-369.4763	-59.09205	270.9199
AI 1/U2 [V]	242.1727	290.8330	48.66028	273.0363
AI 1/U3 [V]	70.06813	77.70014	7.632018	269.0610
AI 1/I1 [A]	-97.00279	1.308764	98.31155	34.22487
AI 1/I2 [A]	77.68235	2.845614	-74.83674	28.26965
AI 1/I3 [A]	19.41109	-4.052872	-23.46397	34.74972
U1_IRMS@POWER/0 [V]	231.0146	275.8612	44.84655	254.2653
U2_IRMS@POWER/0 [V]	230.9000	275.8370	45.00699	253.7503
U3_IRMS@POWER/0 [V]	230.9001	275.7107	44.81053	253.5395
I1_IRMS@POWER/0 [A]	72.71198	23.37398	-49.33801	44.94110
I2_IRMS@POWER/0 [A]	73.13728	13.16113	-59.97615	43.55007
I3_IRMS@POWER/0 [A]	72.80503	17.22724	-55.57779	45.69319
P_t_rc@POWER/0 [W]	50489.05	8299.986	-42189.07	28579.51
P_fund_SYM+rc@POWER/0 [W]	50486.83	8287.682	-42199.15	28984.34
Q_t_rc@POWER/0 [var]	628.3224	12240.49	11612.17	16939.79
Q_fund_SYM+rc@POWER/0 [var]	350.0948	1371.082	1020.987	2238.825

t1+60ms

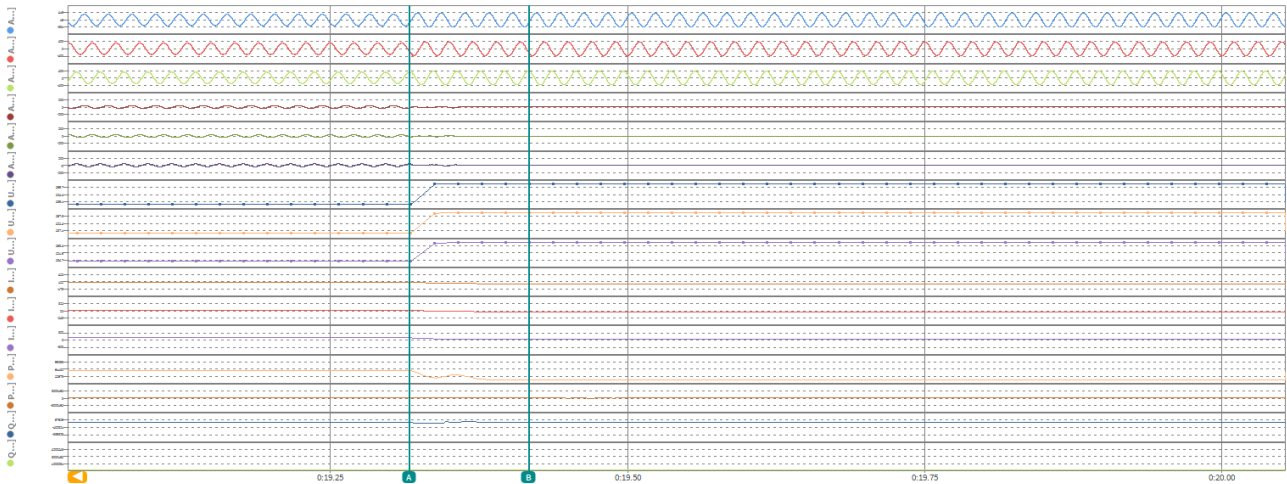

	A	B	Delta	RMS
Time [s]	0:19.31698	0:19.41723	0.10025	
AI 1/U1 [V]	-191.2809	-209.4381	-18.15724	275.2686
AI 1/U2 [V]	-133.8711	-179.6177	-45.74657	274.3614
AI 1/U3 [V]	324.6913	388.8183	64.12697	273.9207
AI 1/I1 [A]	-99.84131	1.418675	61.25999	19.12604
AI 1/I2 [A]	-42.43032	1.110641	43.54096	20.34131
AI 1/I3 [A]	102.4195	-2.440327	-104.8598	22.56875
U1_IRMS@POWER/0 [V]	231.0146	275.6763	44.66165	261.5767
U2_IRMS@POWER/0 [V]	230.9000	275.6823	44.78226	261.2900
U3_IRMS@POWER/0 [V]	230.9001	275.5614	44.66127	261.0908
I1_IRMS_rc@POWER/0 [A]	72.70412	3.507911	-69.19621	32.09502
I2_IRMS_rc@POWER/0 [A]	73.13094	2.226427	-70.90452	30.78970
I3_IRMS_rc@POWER/0 [A]	72.80261	3.096638	-69.70597	32.75044
P_t_rc@POWER/0 [W]	50485.59	67.80511	-50417.78	19932.31
P_fund_SYM+rc@POWER/0 [W]	50483.31	65.15671	-50418.16	20284.81
Q_t_rc@POWER/0 [var]	627.4041	2433.441	1806.037	13386.98
Q_fund_SYM+rc@POWER/0 [var]	346.9849	1284.628	937.6428	1960.434

t1+100ms

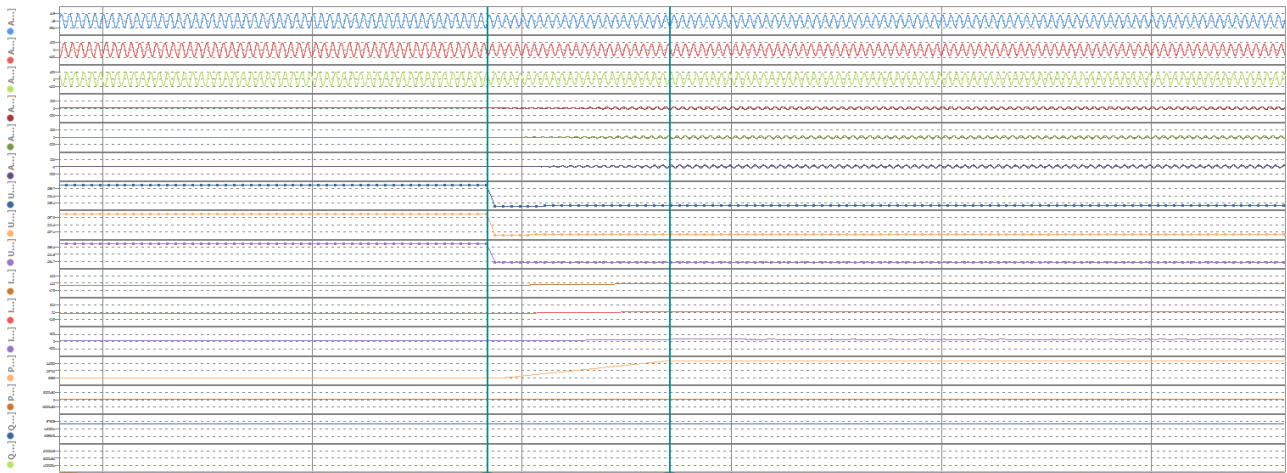

	A	B	Delta	RMS
Time [s]	0:24.41846	0:24.85365	0.43518	
AI 1/U1 [V]	-78.45045	-326.3970	-247.9465	230.3295
AI 1/U2 [V]	-292.4478	191.5012	483.9490	231.4175
AI 1/U3 [V]	370.8022	134.1701	-236.6321	230.0890
AI 1/I1 [A]	-1.784479	-103.4171	-101.6326	41.69983
AI 1/I2 [A]	0.736582	63.48059	62.74391	42.15607
AI 1/I3 [A]	1.129753	40.09009	38.96034	41.58249
U1_IRMS@POWER/0 [V]	275.9922	231.1261	-44.86610	234.6583
U2_IRMS@POWER/0 [V]	275.8987	231.0164	-44.88234	234.7775
U3_IRMS@POWER/0 [V]	275.9225	231.0346	-44.88792	234.7921
I1_IRMS_rc@POWER/0 [A]	1.673507	72.13218	70.45867	40.18963
I2_IRMS_rc@POWER/0 [A]	1.667216	72.80573	71.13846	40.36123
I3_IRMS_rc@POWER/0 [A]	1.666292	72.28794	70.61925	40.21969
P_t_rc@POWER/0 [W]	42.24375	50157.90	50115.65	27836.04
P_fund_SYM+rc@POWER/0 [W]	41.81964	50148.68	50106.86	27830.60
Q_t_rc@POWER/0 [var]	1381.569	-1877.496	-3259.065	1601.698
Q_fund_SYM+rc@POWER/0 [var]	1291.341	-245.3341	-1536.675	528.2076

Active power rising time

Condition						Measurement
	No.	Parameter	Phase ref.	Time ref.	unit	
General Info.	0	Test number	--	--	--	6.2
	1	Date	--	--	dd.mm.yyyy	15.05.2025
	2	Time (start of test)	--	--	hh:mm:ss.f	10:34:14
	3	Fault type (phase)	--	--		A
	4	Setting voltage depth	Line to line	--		1.2
	5	Setting dip duration		--		5000
	6	Point of fault entry	Total	--		18024
	7	Point of fault clearance	Total	--		23124
	8	Fault duration in empty load test	Total	--		5006
	9	Voltage depth/height in empty load test	Total	t1+100ms to t2 and t1-10s to t1		1.200
10	Pos.				1.000	
Before dip <t1	11	Voltage	Line to neutral	t1-100s to t1	p.u.	1.001
	12	Current	Pos.	t1-500ms to t1-100ms	p.u.	0.500
	13	Active power	Total	t1-10s to t1	p.u.	0.500
	14		Pos.			0.500
	15	Reactive power	Total	t1-10s to t1	p.u.	0.008
	16		Pos.			0.001
17	Cosφ	--	t1-10s to t1	--	0.999	
During dip t1 to t2	18	Voltage	Line to neutral	t1+100ms to t2-20ms	p.u.	1.198
	19	Line current	Phase 1	t1+60ms	p.u.	0.080
	20		Phase 2			0.145
	21		Phase 3			0.199
	22	Line current	Phase 1	t1+100ms	p.u.	0.039
	23		Phase 2			0.025
	24		Phase 3			0.038
	25	Active power	Total	t1+100ms to t2-20ms	p.u.	0.001
26	Pos.		0.001			
After dip > t2	27	Voltage	Line to neutral	t2+3s to t2+10s	p.u.	1.001
	28	Active power	Total	t2+3s to t2+10s	p.u.	0.499
	29		Pos.			0.499
	39	Active power rising time	Pos.	--	s	0.236
	31	Reactive power	Total	t2+3s to t2+10s	p.u.	0.008
	32		Pos.			0.001
	33	Reactive power rising time	Pos.	--	s	--
	34	PGU does not disconnect from grid till 60s after fault	--	t2 to t2+60s	Yes / No	Yes

Test No. 6.2 idle test

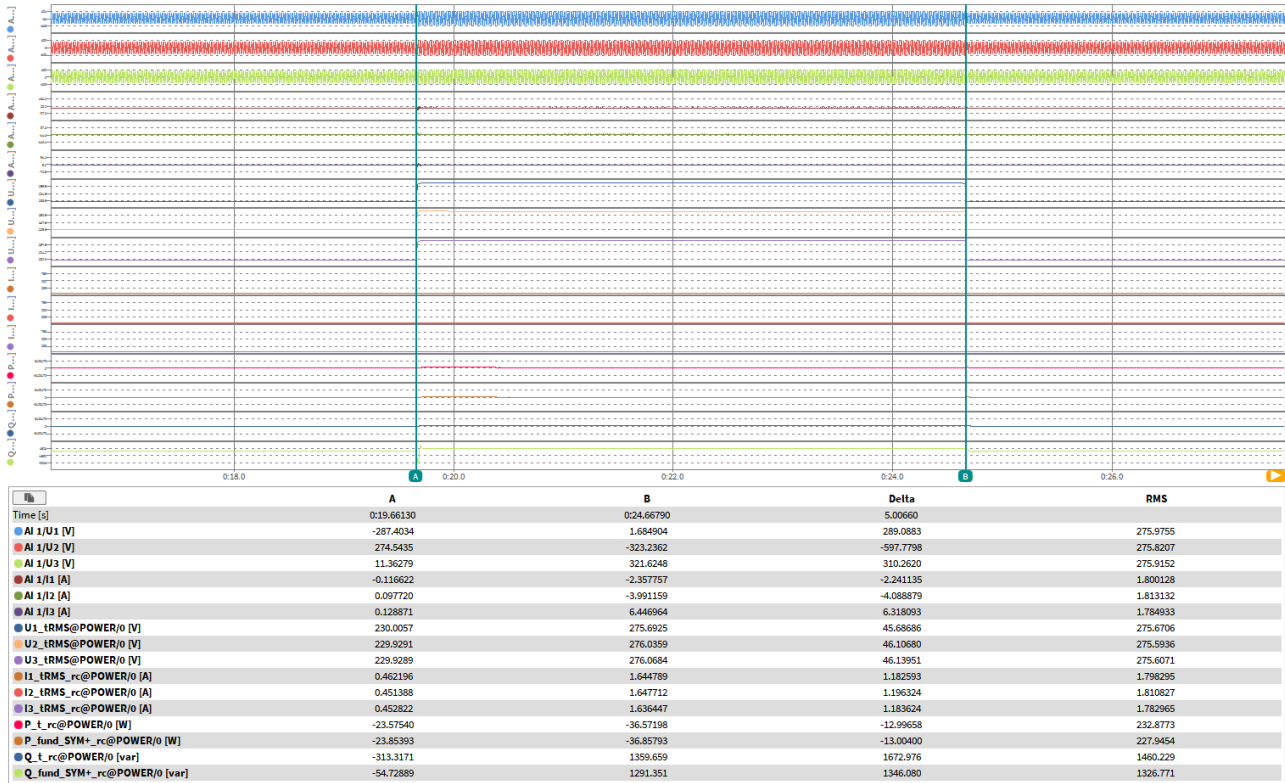

Test No. 6.2 with PGU

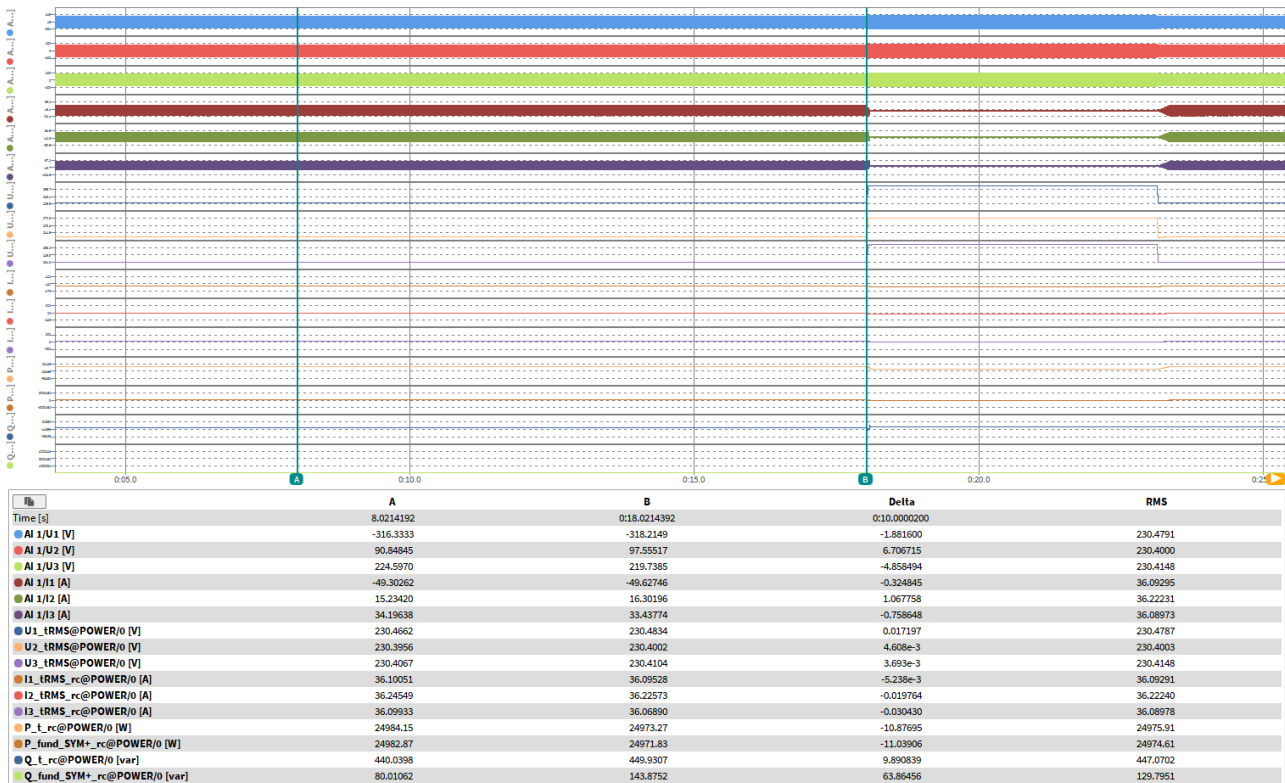

t1-10s to t1

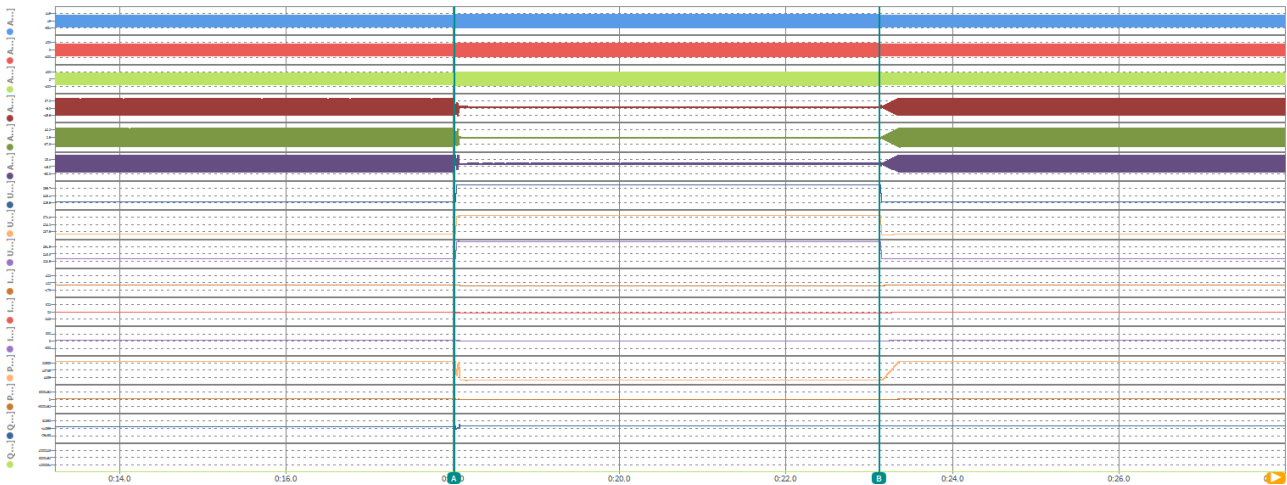

	A	B	Delta	RMS
Time [s]	0:18.0243281	0:23.1246738	5.1003457	
AI 1/U1 [V]	-139.5912	-142.0236	-2.432346	275.9626
AI 1/U2 [V]	-185.6330	-243.6130	-57.98006	275.8734
AI 1/U3 [V]	324.7814	365.6373	60.85587	275.8941
AI 1/I1 [A]	-22.98836	-2.023971	20.96439	2.756625
AI 1/I2 [A]	-29.13705	1.863567	31.00062	2.707478
AI 1/I3 [A]	52.23132	0.247604	-51.98372	2.831546
U1_IRMS@POWER/0 [V]	230.4834	275.9919	45.50848	275.6630
U2_IRMS@POWER/0 [V]	230.4002	275.8950	45.49481	275.5614
U3_IRMS@POWER/0 [V]	230.4104	275.9237	45.51329	275.5803
I1_IRMS@POWER/0 [A]	36.09297	1.655207	-34.43777	3.267052
I2_IRMS@POWER/0 [A]	36.23235	1.673994	-34.55835	3.120701
I3_IRMS@POWER/0 [A]	36.07954	1.667730	-34.41181	3.290573
P_t_rc@POWER/0 [W]	24977.29	47.25259	-24930.03	1795.242
P_fund_SYM+rc@POWER/0 [W]	24975.75	46.67382	-24929.08	1815.091
Q_t_rc@POWER/0 [var]	449.2308	1378.016	928.7857	1833.868
Q_fund_SYM+rc@POWER/0 [var]	139.7384	1287.487	1147.748	1304.260

t1 to t2

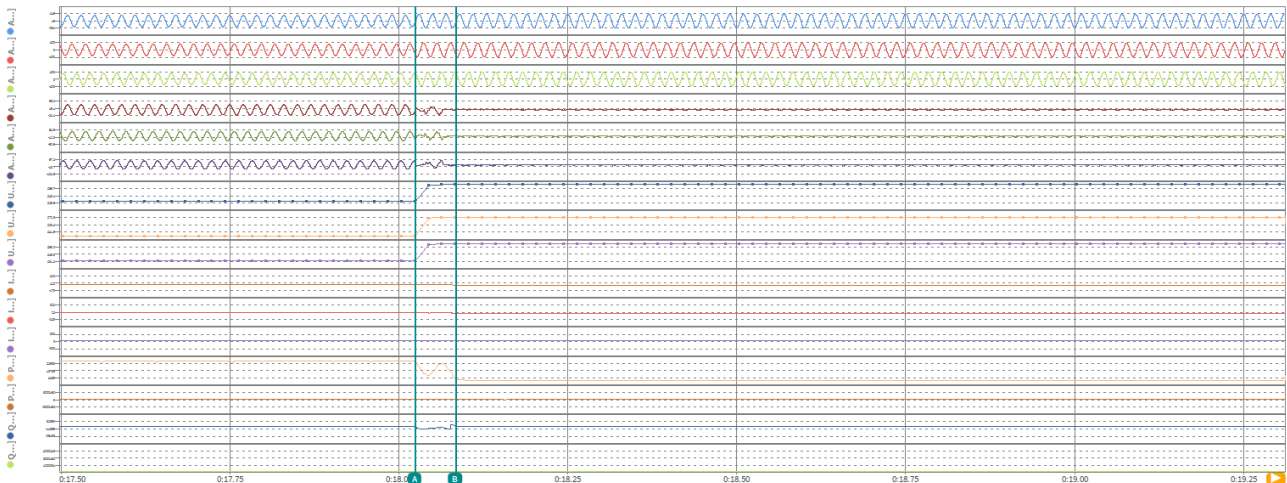

	A	B	Delta	RMS
Time [s]	0:18.0243281	0:18.0843379	0.0600097	
AI 1/U1 [V]	-139.5912	-171.4902	-31.89898	275.5100
AI 1/U2 [V]	-185.6330	-217.3588	-31.72589	274.2243
AI 1/U3 [V]	324.7814	388.8407	64.05926	273.4445
AI 1/I1 [A]	-22.98836	-0.070965	22.91739	20.12713
AI 1/I2 [A]	-29.13705	9.831594	32.96864	19.66680
AI 1/I3 [A]	52.23132	-3.662819	-55.89414	21.03498
U1_IRMS@POWER/0 [V]	230.4834	276.1261	45.64267	254.0680
U2_IRMS@POWER/0 [V]	230.4002	276.0933	45.69305	253.8356
U3_IRMS@POWER/0 [V]	230.4104	276.2635	45.85310	253.7396
I1_IRMS@POWER/0 [A]	36.09297	5.776223	-30.31675	25.60657
I2_IRMS@POWER/0 [A]	36.23235	10.51823	-25.71411	24.09749
I3_IRMS@POWER/0 [A]	36.07954	14.39889	-21.68065	25.86947
P_t_rc@POWER/0 [W]	24977.29	3837.546	-21139.74	16405.66
P_fund_SYM+rc@POWER/0 [W]	24975.75	3849.434	-21126.32	16587.44
Q_t_rc@POWER/0 [var]	449.2308	7517.169	7067.939	10969.52
Q_fund_SYM+rc@POWER/0 [var]	139.7384	1152.403	1012.665	2184.510

t1+60ms

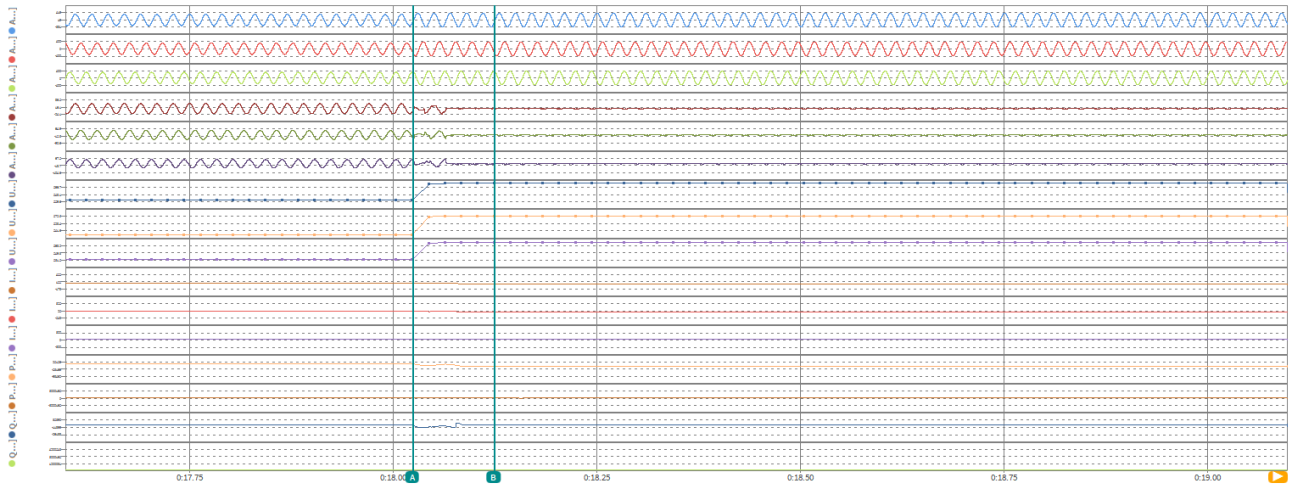

	A	B	Delta	RMS
Time [s]	0:18.0243281	0:18.1243650	0.1000369	
AI 1/U1 [V]	-139.5912	-172.4577	-32.86648	275.6807
AI 1/U2 [V]	-185.6330	-217.1734	-31.53849	274.8917
AI 1/U3 [V]	324.7814	389.6265	64.84509	274.4085
AI 1/I1 [A]	-22.98836	0.977600	23.96596	15.68419
AI 1/I2 [A]	-29.13705	1.464574	30.60162	15.28915
AI 1/I3 [A]	52.23132	-2.353543	-54.58486	16.38490
U1_IRMS@POWER/0 [V]	230.4834	275.9249	45.44150	261.5168
U2_IRMS@POWER/0 [V]	230.4002	275.8772	45.47699	261.2844
U3_IRMS@POWER/0 [V]	230.4104	275.8288	45.41841	261.2081
I1_IRMS_rc@POWER/0 [A]	36.09297	2.865970	-33.22700	19.96314
I2_IRMS_rc@POWER/0 [A]	36.23235	1.861353	-34.37099	18.79741
I3_IRMS_rc@POWER/0 [A]	36.07954	2.766196	-33.31334	20.18255
P_t_rc@POWER/0 [W]	24977.29	44.62686	-24932.66	12754.18
P_fund_SYM+rc@POWER/0 [W]	24975.75	42.48516	-24933.26	12895.41
Q_t_rc@POWER/0 [var]	449.2308	2066.823	1617.592	8625.315
Q_fund_SYM+rc@POWER/0 [var]	139.7384	1257.776	1118.038	1878.287

t1+100ms

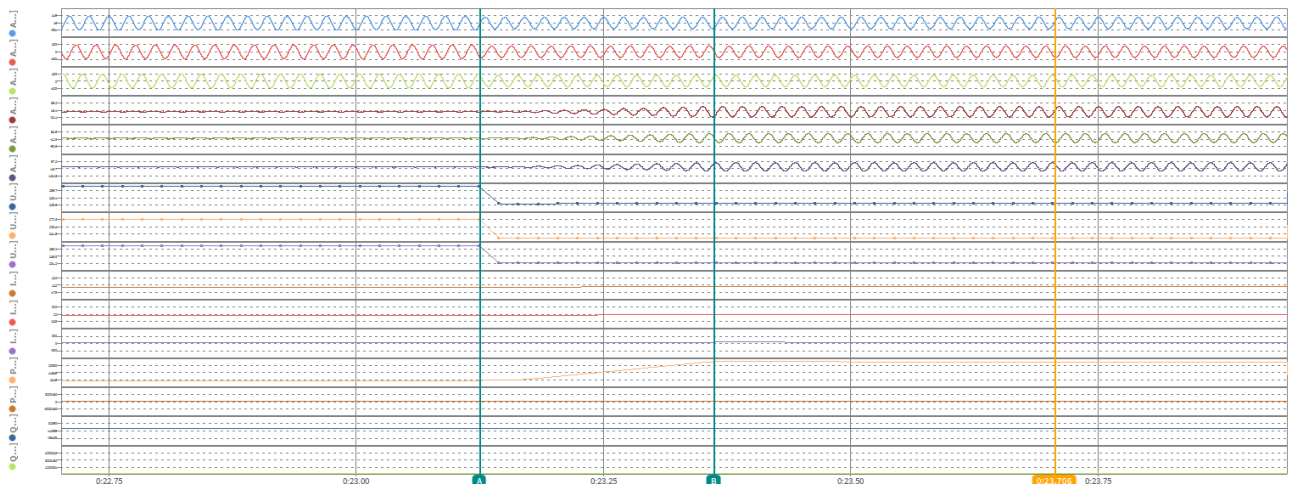

	A	B	Delta	RMS
Time [s]	0:23.1252623	0:23.3622273	0.2369650	
AI 1/U1 [V]	-72.21294	-293.1497	-220.9368	230.6007
AI 1/U2 [V]	-296.9048	20.54072	317.4455	231.2139
AI 1/U3 [V]	369.0741	271.0641	-98.01007	229.2822
AI 1/I1 [A]	-1.867449	-43.91865	-42.05120	21.27254
AI 1/I2 [A]	0.597088	-0.692041	-1.289129	21.18885
AI 1/I3 [A]	1.345164	44.71005	43.36489	20.90954
U1_IRMS@POWER/0 [V]	275.9919	230.5518	-45.44006	237.6578
U2_IRMS@POWER/0 [V]	275.8990	230.4752	-45.41978	237.7885
U3_IRMS@POWER/0 [V]	275.9237	230.4896	-45.43407	237.6080
I1_IRMS_rc@POWER/0 [A]	1.656095	36.30843	34.65233	19.73906
I2_IRMS_rc@POWER/0 [A]	1.674264	36.35083	34.67657	19.79540
I3_IRMS_rc@POWER/0 [A]	1.667903	36.03123	34.36332	19.72506
P_t_rc@POWER/0 [W]	47.45327	25016.82	24969.37	13581.37
P_fund_SYM+rc@POWER/0 [W]	46.98101	25012.01	24965.03	13578.55
Q_t_rc@POWER/0 [var]	1378.384	1357.469	-20.91528	1415.275
Q_fund_SYM+rc@POWER/0 [var]	1288.050	88.18810	-1199.862	613.7492

Active power rising time

Condition						Measurement
No.	Parameter	Phase ref.	Time ref.	unit		
General Info.	0	Test number	--	--	--	6.3
	1	Date	--	--	dd.mm.yyyy	26.06.2025
	2	Time (start of test)	--	--	hh:mm:ss.f	14:52:41
	3	Fault type (phase)	--	--		D1
	4	Setting voltage depth	Line to line	--	p.u.	1.2
	5	Setting dip duration		--		5000
	6	Point of fault entry	Total	--	ms	17983
	7	Point of fault clearance	Total	--	ms	22992
	8	Fault duration in empty load test	Total	--	ms	5114
	9	Voltage depth/height in empty load test	Total	t1+100ms to t2 and t1-10s to t1	p.u.	1.200
10	Pos.		p.u.		1.000	
Before dip <t1	11	Voltage	Line to neutral	t1-100s to t1	p.u.	1.004
	12	Current	Pos.	t1-500ms to t1-100ms	p.u.	1.011
	13	Active power	Total	t1-10s to t1	p.u.	1.009
	14		Pos.			1.009
	15	Reactive power	Total	t1-10s to t1	p.u.	0.012
	16		Pos.			0.007
17	Cos ϕ	--	t1-10s to t1	--	0.999	
During dip t1 to t2	18	Voltage	Line to neutral	t1+100ms to t2-20ms	p.u.	1.198
	19	Line current	Phase 1	t1+60ms	p.u.	0.054
	20		Phase 2			0.057
	21		Phase 3			0.026
	22	Line current	Phase 1	t1+100ms	p.u.	0.024
	23		Phase 2			0.026
	24		Phase 3			0.020
	25	Active power	Total	t1+100ms to t2-20ms	p.u.	0.003
26	Pos.		0.001			
After dip > t2	27	Voltage	Line to neutral	t2+3s to t2+10s	p.u.	1.004
	28	Active power	Total	t2+3s to t2+10s	p.u.	1.009
	29		Pos.			1.009
	39	Active power rising time	Pos.	--	s	0.472
	31	Reactive power	Total	t2+3s to t2+10s	p.u.	0.013
	32		Pos.			0.007
	33	Reactive power rising time	Pos.	--	s	--
	34	PGU does not disconnect from grid till 60s after fault	--	t2 to t2+60s	Yes / No	Yes

Test No. 6.3 idle test

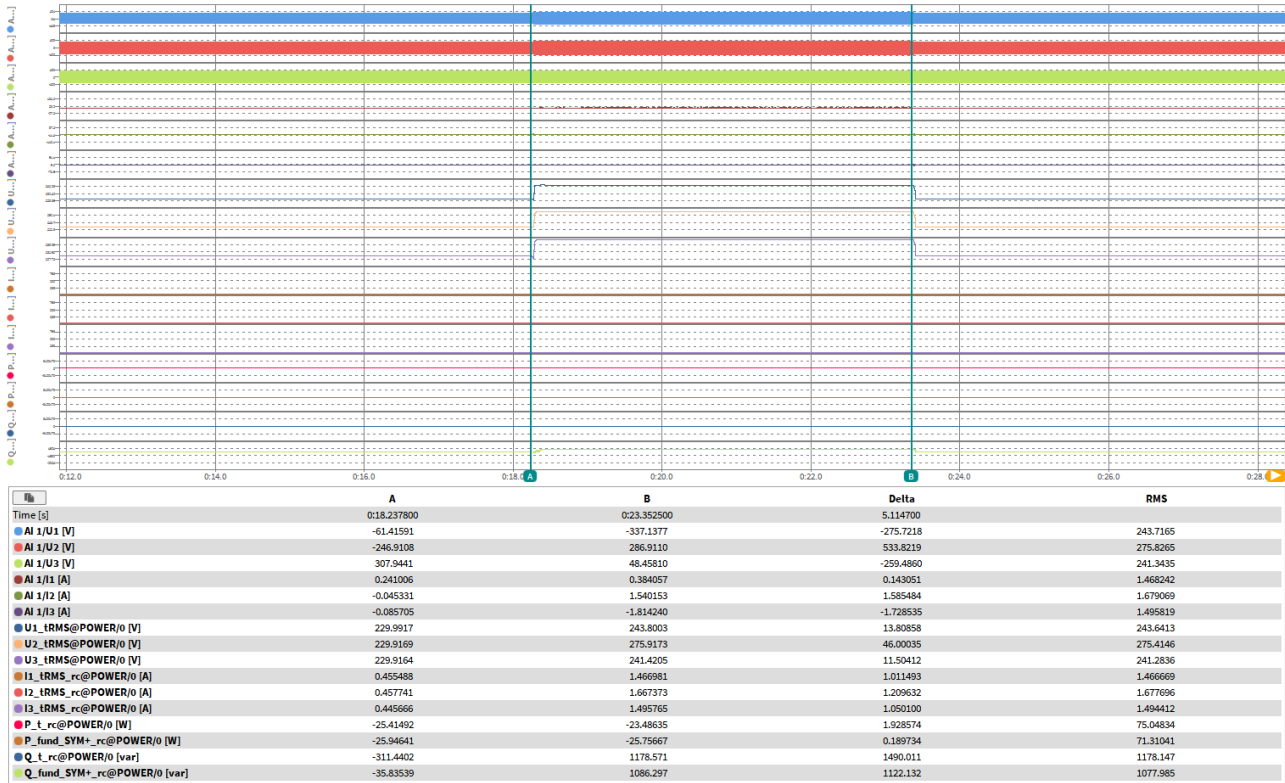

Test No. 6.3 with PGU

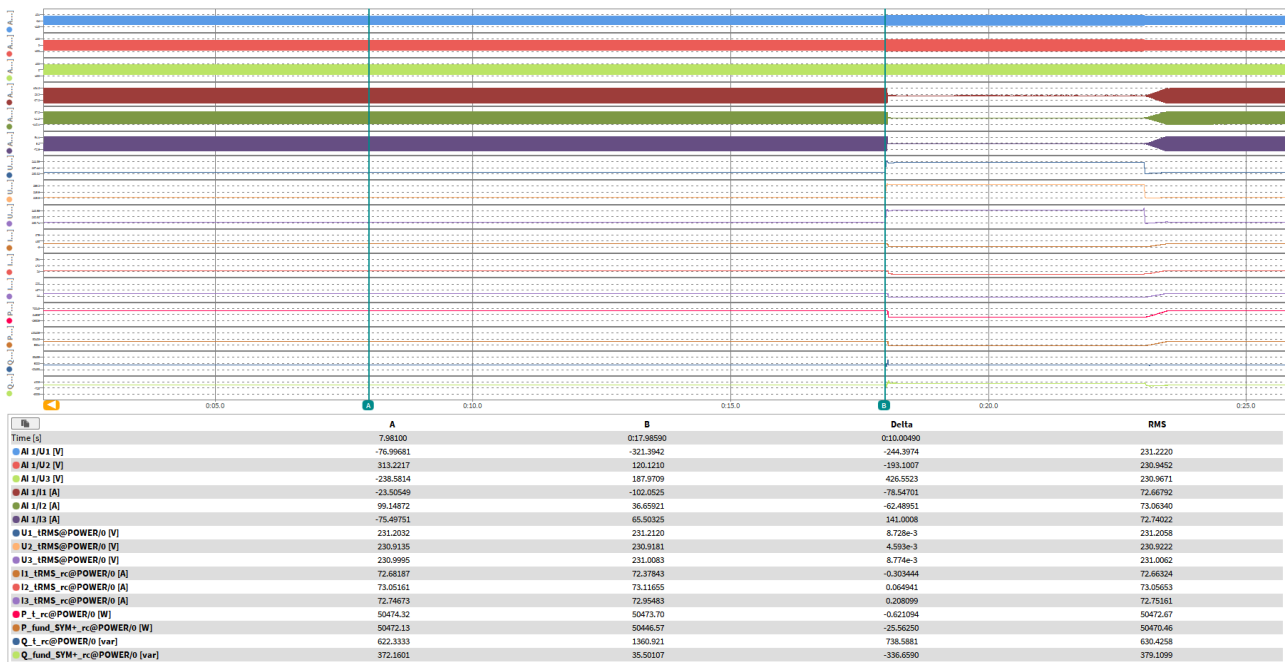

t1-10s to t1

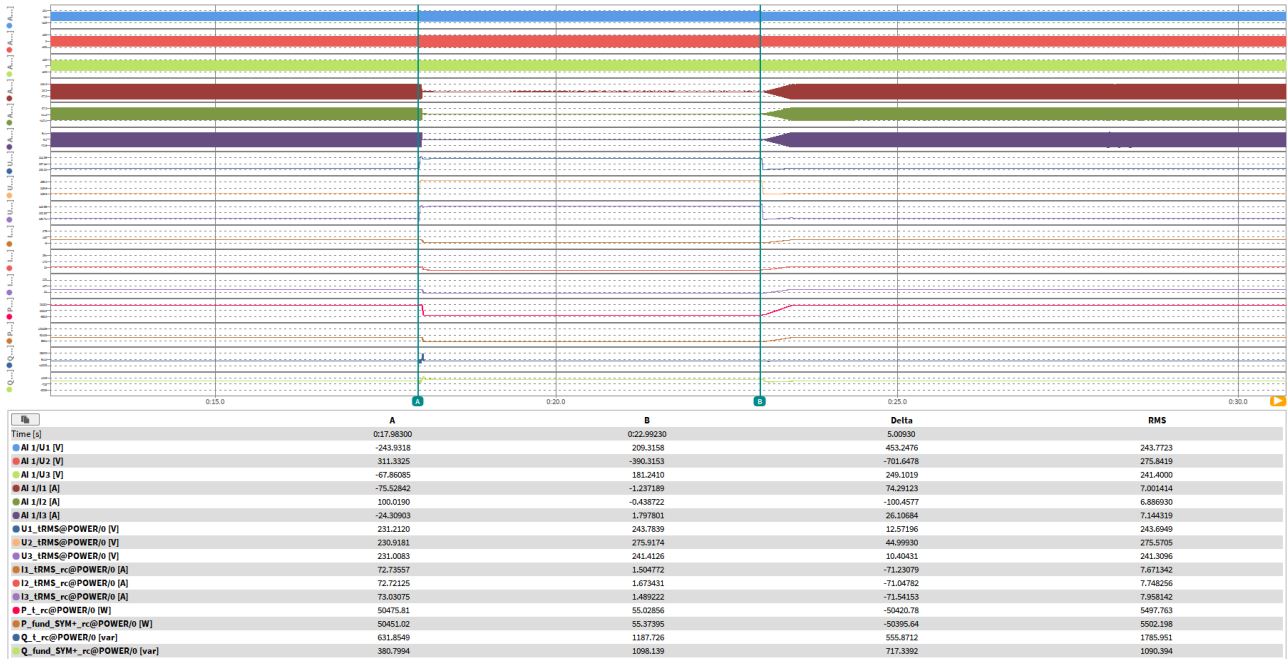

t1 to t2

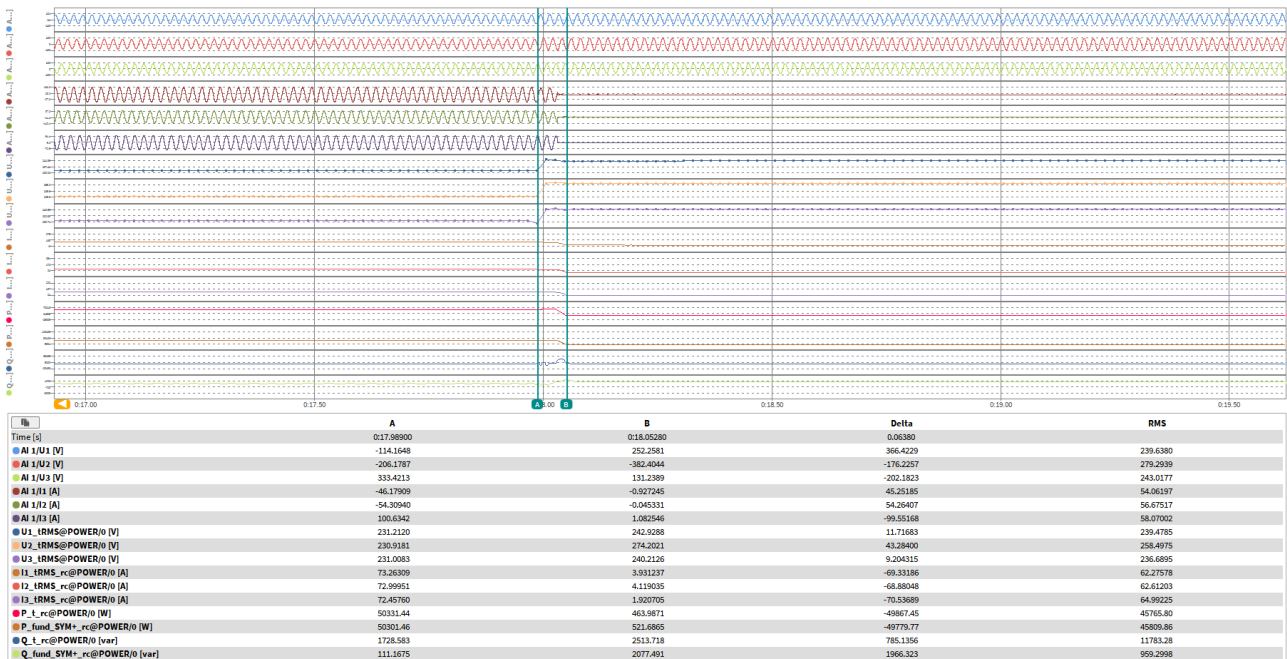

t1+60ms

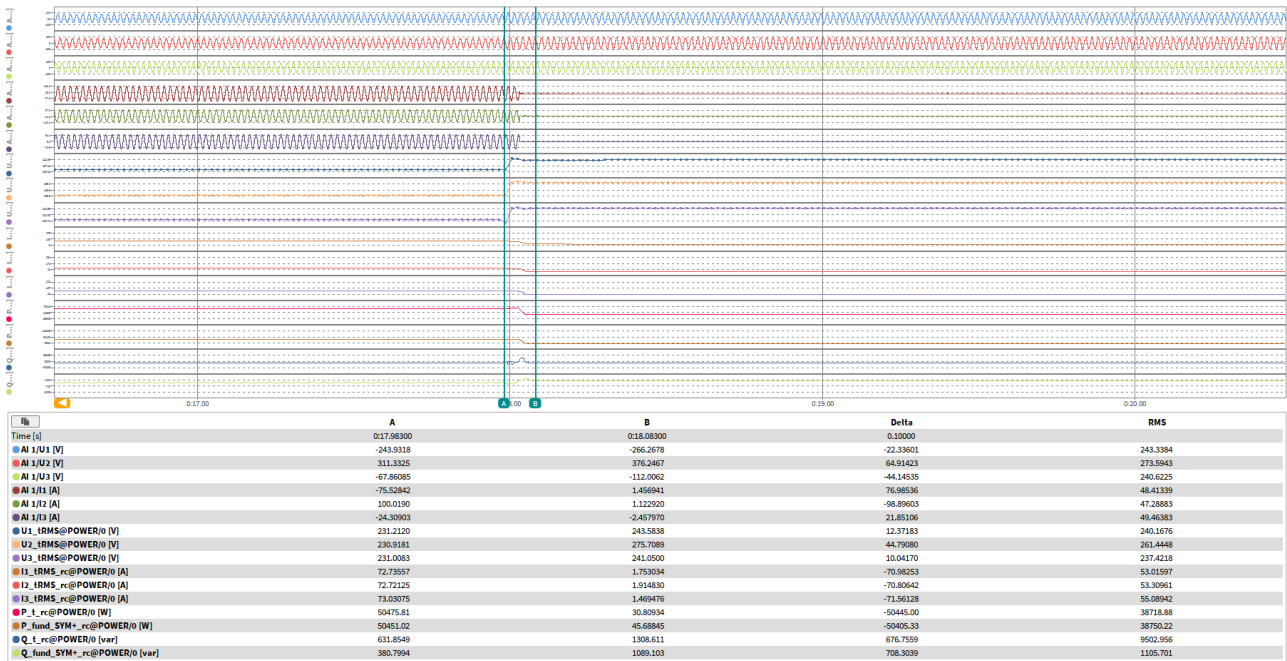

t1+100ms

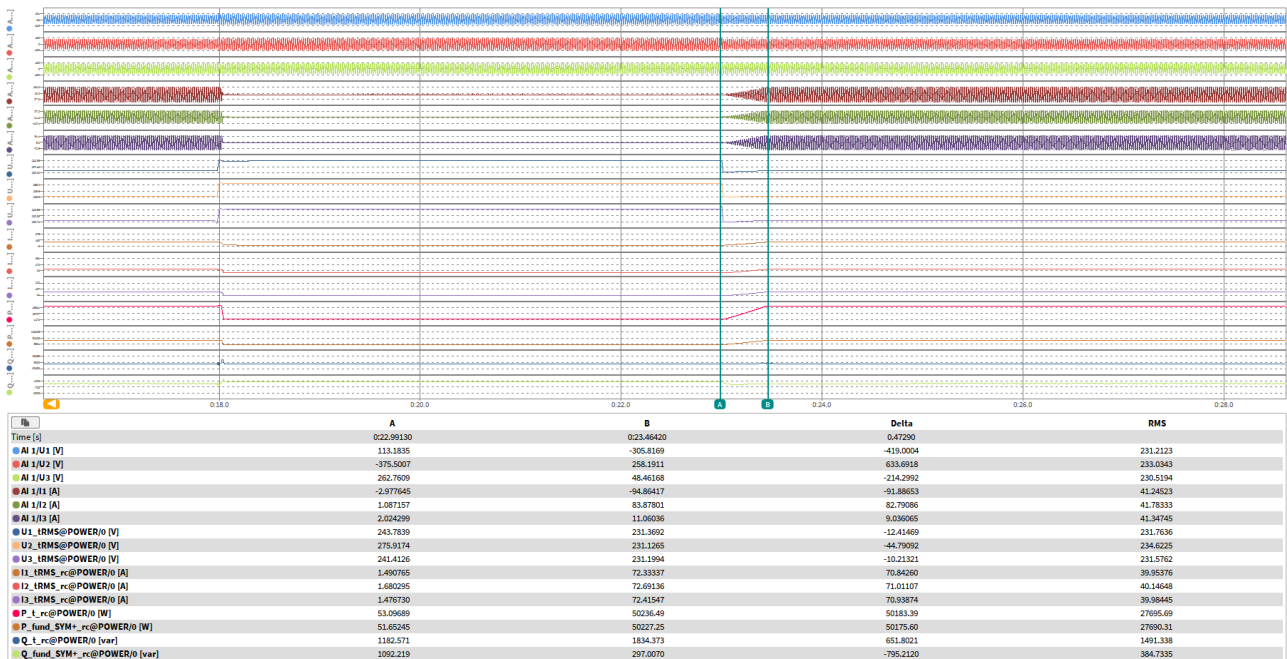

Active power rising time

Condition						Measurement
No.	Parameter	Phase ref.	Time ref.	unit		
General Info.	0	Test number	--	--	--	6.4
	1	Date	--	--	dd.mm.yyyy	26.06.2025
	2	Time (start of test)	--	--	hh:mm:ss.f	14:54:51
	3	Fault type (phase)	--	--		D1
	4	Setting voltage depth	Line to line	--	p.u.	1.2
	5	Setting dip duration		--		5000
	6	Point of fault entry	Total	--	ms	20293
	7	Point of fault clearance	Total	--	ms	25313
	8	Fault duration in empty load test	Total	--	ms	5114
	9	Voltage depth/height in empty load test	Total	t1+100ms to t2 and t1-10s to t1	p.u.	1.200
10	Pos.		p.u.		1.000	
Before dip <t1	11	Voltage	Line to neutral	t1-100s to t1	p.u.	1.002
	12	Current	Pos.	t1-500ms to t1-100ms	p.u.	0.499
	13	Active power	Total	t1-10s to t1	p.u.	0.499
	14		Pos.			0.499
	15	Reactive power	Total	t1-10s to t1	p.u.	0.008
	16		Pos.			0.002
17	Cos ϕ	--	t1-10s to t1	--	0.999	
During dip t1 to t2	18	Voltage	Line to neutral	t1+100ms to t2-20ms	p.u.	1.199
	19	Line current	Phase 1	t1+60ms	p.u.	0.461
	20		Phase 2			0.458
	21		Phase 3			0.438
	22	Line current	Phase 1	t1+100ms	p.u.	0.023
	23		Phase 2			0.027
	24		Phase 3			0.020
	25	Active power	Total	t1+100ms to t2-20ms	p.u.	0.001
26	Pos.		0.001			
After dip > t2	27	Voltage	Line to neutral	t2+3s to t2+10s	p.u.	1.002
	28	Active power	Total	t2+3s to t2+10s	p.u.	0.499
	29		Pos.			0.499
	39	Active power rising time	Pos.	--	s	0.265
	31	Reactive power	Total	t2+3s to t2+10s	p.u.	0.010
	32		Pos.			0.002
	33	Reactive power rising time	Pos.	--	s	--
	34	PGU does not disconnect from grid till 60s after fault	--	t2 to t2+60s	Yes / No	Yes

Test No. 6.4 idle test

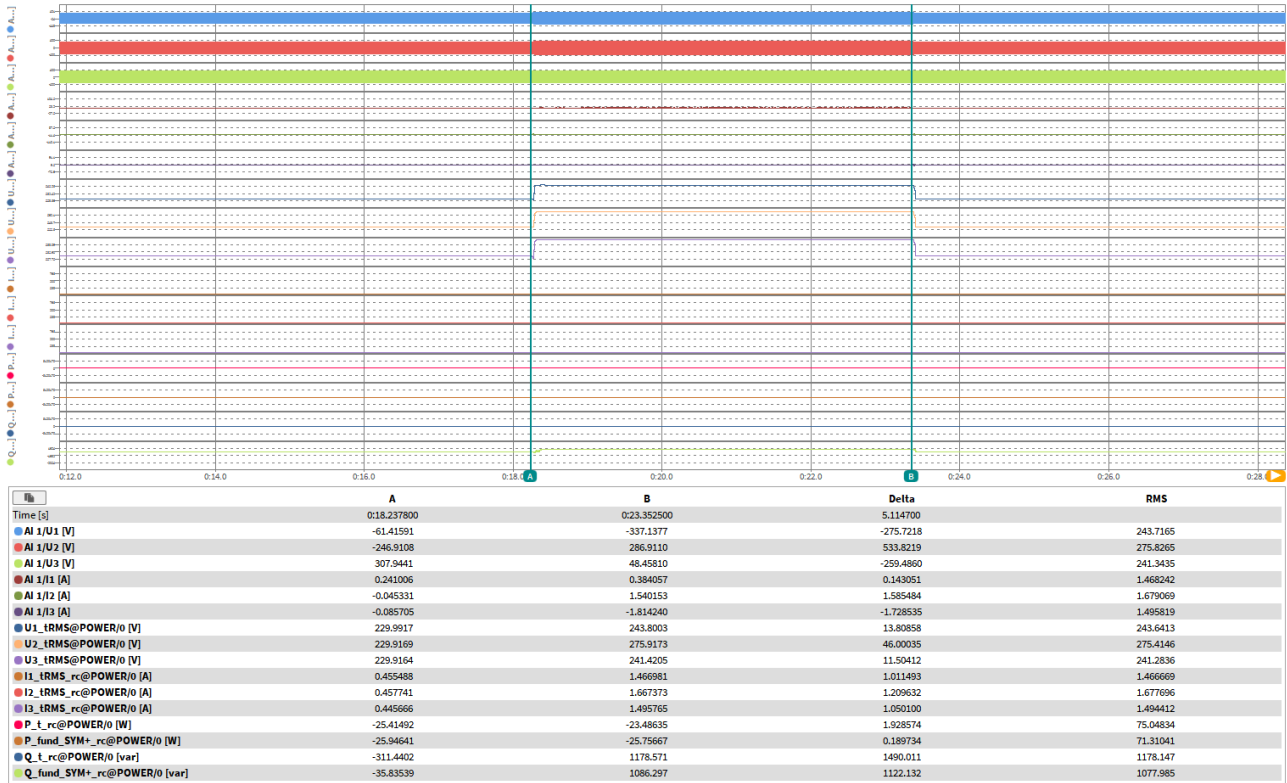

Test No. 6.4 with PGU

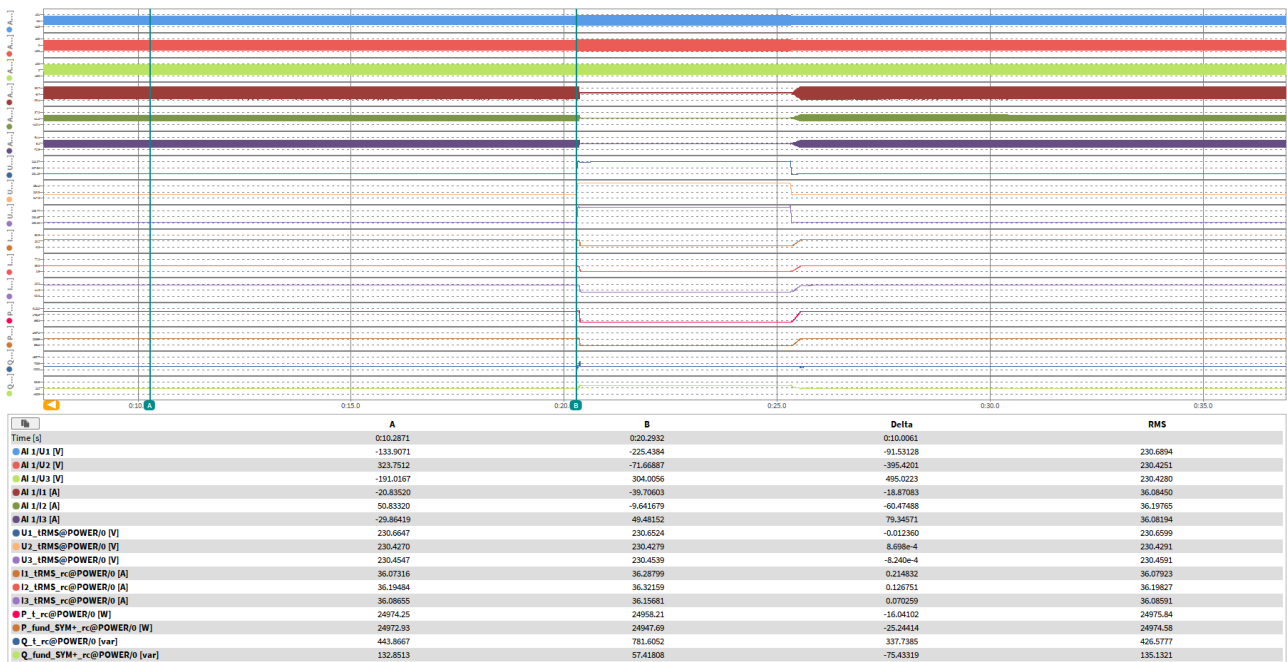

t1-10s to t1

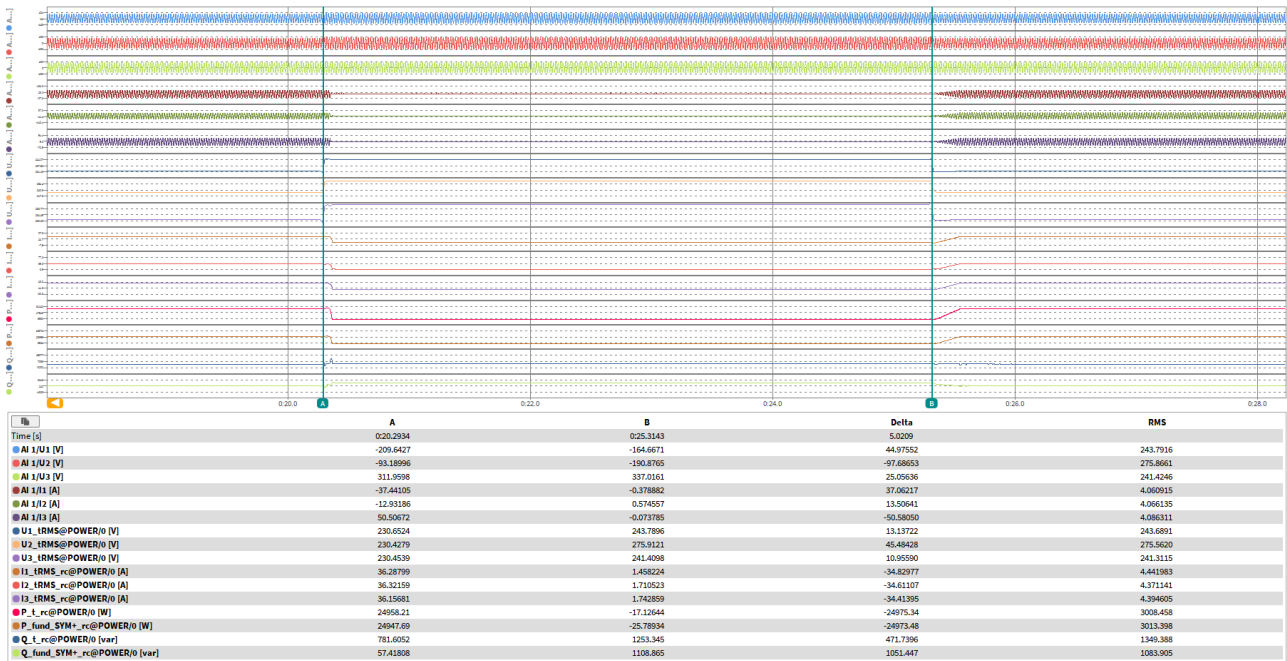

t1 to t2

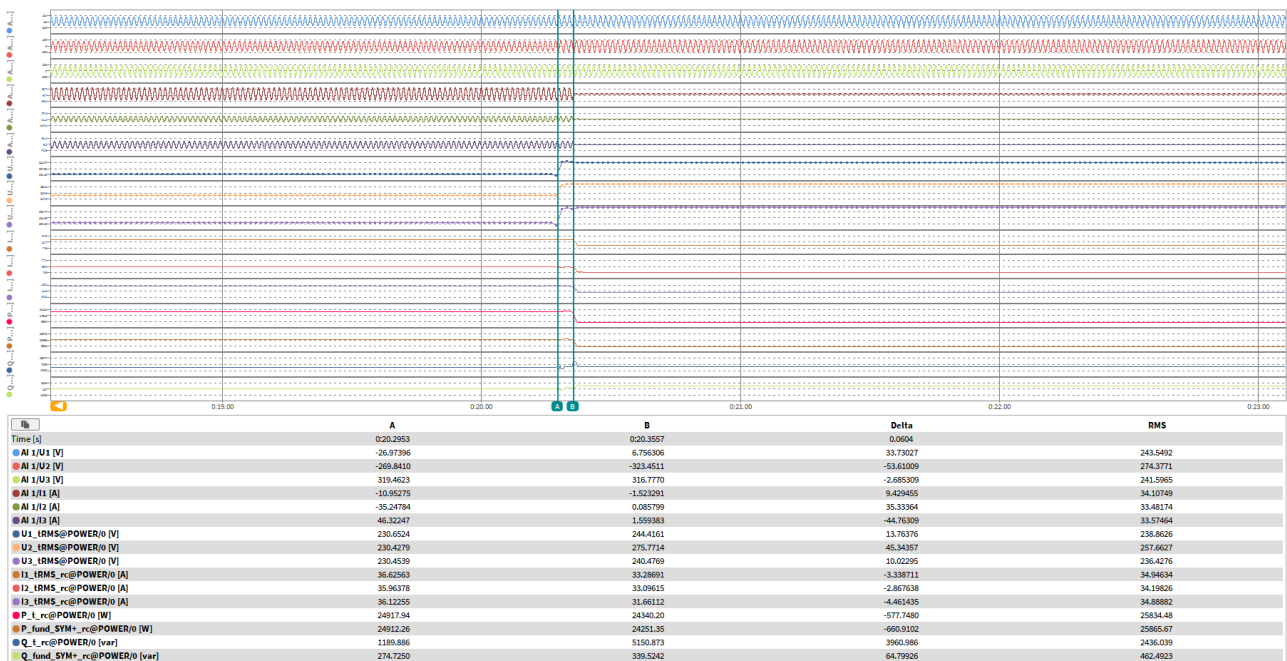

t1+60ms

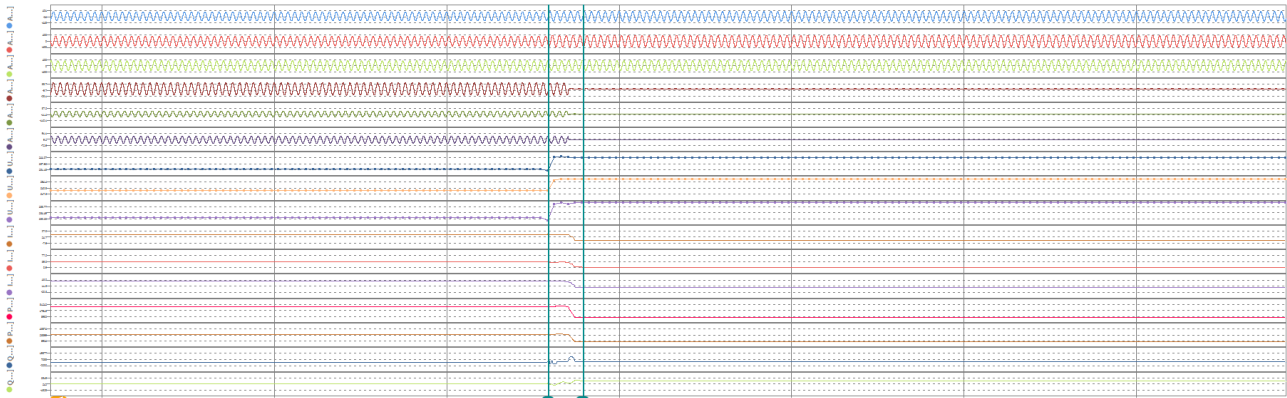

	A	B	Delta	RMS
Time [s]	0:20:3953	0:20:3956	0:0003	
AI 1/U1 [V]	-26.97396	-2.556086	24.41788	243.7445
AI 1/U2 [V]	-269.8410	-317.5893	-47.74833	274.9528
AI 1/U3 [V]	319.4623	321.3585	1.896143	241.4067
AI 1/I1 [A]	-10.95275	-1.177585	9.775162	26.50608
AI 1/I2 [A]	-35.24784	-9.568e-3	35.23827	26.03483
AI 1/I3 [A]	46.32247	1.389443	-45.01343	26.86599
U1_IRMS@POWER0 [V]	230.6524	243.7172	13.06479	240.2428
U2_IRMS@POWER0 [V]	230.4279	275.9023	45.47440	263.0258
U3_IRMS@POWER0 [V]	230.4539	241.3147	10.86081	237.8567
I1_IRMS_rc@POWER0 [A]	36.62563	1.724652	-34.90097	29.10202
I2_IRMS_rc@POWER0 [A]	35.96378	1.950318	-34.01346	28.05743
I3_IRMS_rc@POWER0 [A]	36.12255	1.479514	-34.64694	28.76612
P_L_rc@POWER0 [W]	24917.54	29.01750	-24888.53	2991.706
P_fund_SYM+_rc@POWER0 [W]	24912.26	34.00594	-24878.26	2952.38
Q_L_rc@POWER0 [var]	1189.886	1314.225	124.3381	4748.771
Q_fund_SYM+_rc@POWER0 [var]	274.7250	1165.779	891.0543	768.4299

t1+100ms

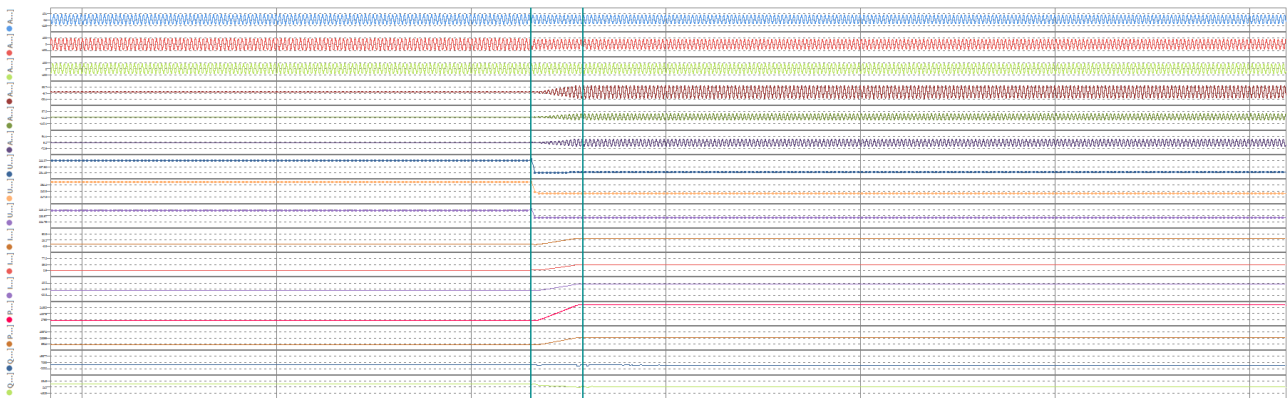

	A	B	Delta	RMS
Time [s]	0:25:3987	0:25:5741	0:02654	
AI 1/U1 [V]	-281.8377	-170.4044	111.4333	232.2294
AI 1/U2 [V]	-367.9497	-155.9343	-212.0154	230.4371
AI 1/U3 [V]	-87.78549	325.1605	412.9460	230.2558
AI 1/I1 [A]	0.372136	-29.03880	-29.40893	22.20421
AI 1/I2 [A]	1.194446	-21.87255	-23.06700	22.01325
AI 1/I3 [A]	-1.444691	51.03124	52.47593	22.04761
U1_IRMS@POWER0 [V]	243.7695	230.6843	-13.10529	232.4994
U2_IRMS@POWER0 [V]	275.9121	230.4421	-45.47003	237.6126
U3_IRMS@POWER0 [V]	241.4098	230.4950	-10.91481	232.0574
I1_IRMS_rc@POWER0 [A]	1.491855	35.75280	34.26095	20.85009
I2_IRMS_rc@POWER0 [A]	1.667211	36.00759	34.34038	20.95963
I3_IRMS_rc@POWER0 [A]	1.493827	35.79588	34.30196	20.85636
P_L_rc@POWER0 [W]	60.30138	24765.14	24704.24	14831.20
P_fund_SYM+_rc@POWER0 [W]	59.63537	24759.94	24700.32	14779.67
Q_L_rc@POWER0 [var]	1184.263	1356.017	171.7538	1310.977
Q_fund_SYM+_rc@POWER0 [var]	1094.802	267.5767	-827.2249	548.6386

Active power rising time

Condition						Measurement
No.	Parameter	Phase ref.	Time ref.	unit		
General Info.	0	Test number	--	--	--	7.1
	1	Date	--	--	dd.mm.yyyy	15.05.2025
	2	Time (start of test)	--	--	hh:mm:ss.f	10:38:15
	3	Fault type (phase)	--	--		A
	4	Setting voltage depth	Line to line	--	p.u.	1.15
	5	Setting dip duration		--		60000
	6	Point of fault entry	Total	--	ms	18123
	7	Point of fault clearance	Total	--	ms	78128
	8	Fault duration in empty load test	Total	--	ms	60004
	9	Voltage depth/height in empty load test	Total	t1+100ms to t2 and t1-10s to t1	p.u.	1.150
10	Pos.		p.u.		1.000	
Before dip <t1	11	Voltage	Line to neutral	t1-100s to t1	p.u.	1.003
	12	Current	Pos.	t1-500ms to t1-100ms	p.u.	1.006
	13	Active power	Total	t1-10s to t1	p.u.	1.009
	14		Pos.			1.008
	15	Reactive power	Total	t1-10s to t1	p.u.	0.014
	16		Pos.			0.006
17	Cos ϕ	--	t1-10s to t1	--	0.999	
During dip t1 to t2	18	Voltage	Line to neutral	t1+100ms to t2-20ms	p.u.	1.153
	19	Line current	Phase 1	t1+60ms	p.u.	0.801
	20		Phase 2			0.804
	21		Phase 3			0.781
	22	Line current	Phase 1	t1+100ms	p.u.	0.898
	23		Phase 2			0.896
	24		Phase 3			0.893
	25	Active power	Total	t1+100ms to t2-20ms	p.u.	1.027
26	Pos.		1.026			
After dip > t2	27	Voltage	Line to neutral	t2+3s to t2+10s	p.u.	1.003
	28	Active power	Total	t2+3s to t2+10s	p.u.	1.009
	29		Pos.			1.007
	39	Active power rising time	Pos.	--	s	0.079
	31	Reactive power	Total	t2+3s to t2+10s	p.u.	0.014
	32		Pos.			0.006
	33	Reactive power rising time	Pos.	--	s	--
	34	PGU does not disconnect from grid till 60s after fault	--	t2 to t2+60s	Yes / No	Yes

Test No. 7.1 idle test

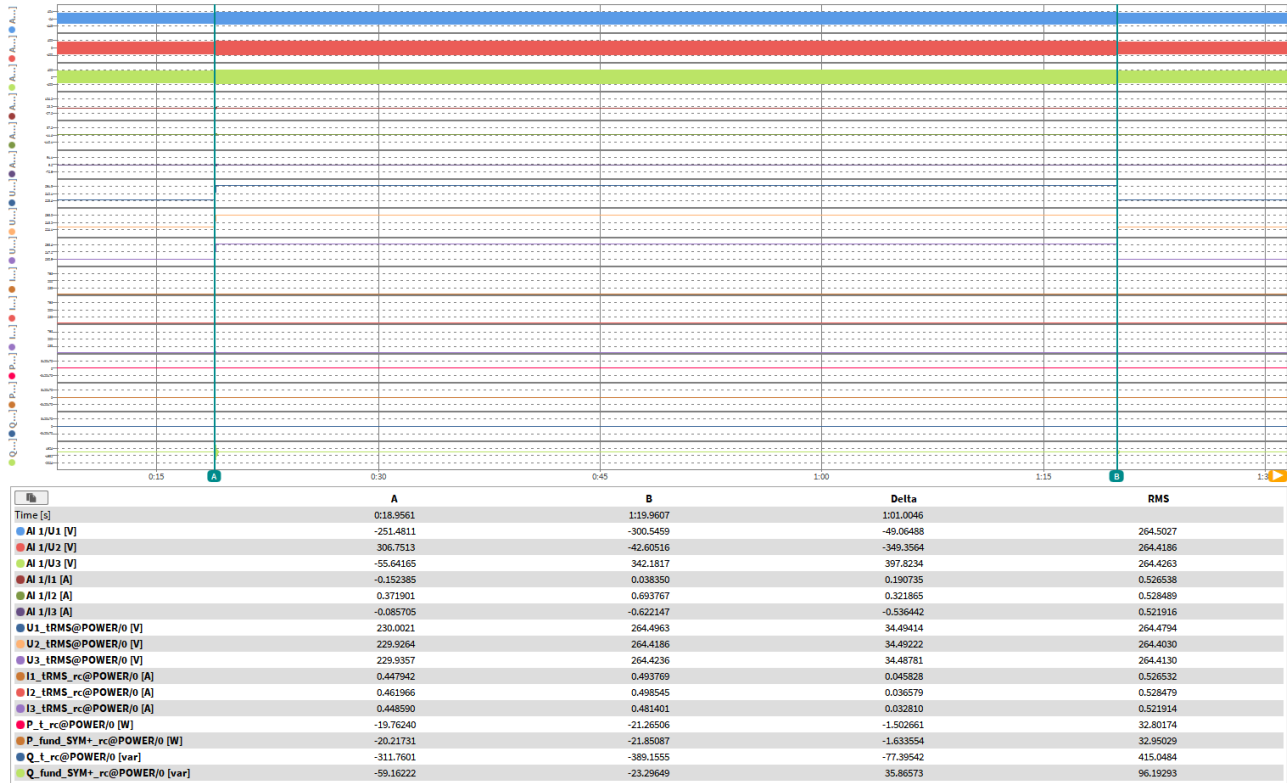

Test No. 7.1 with PGU

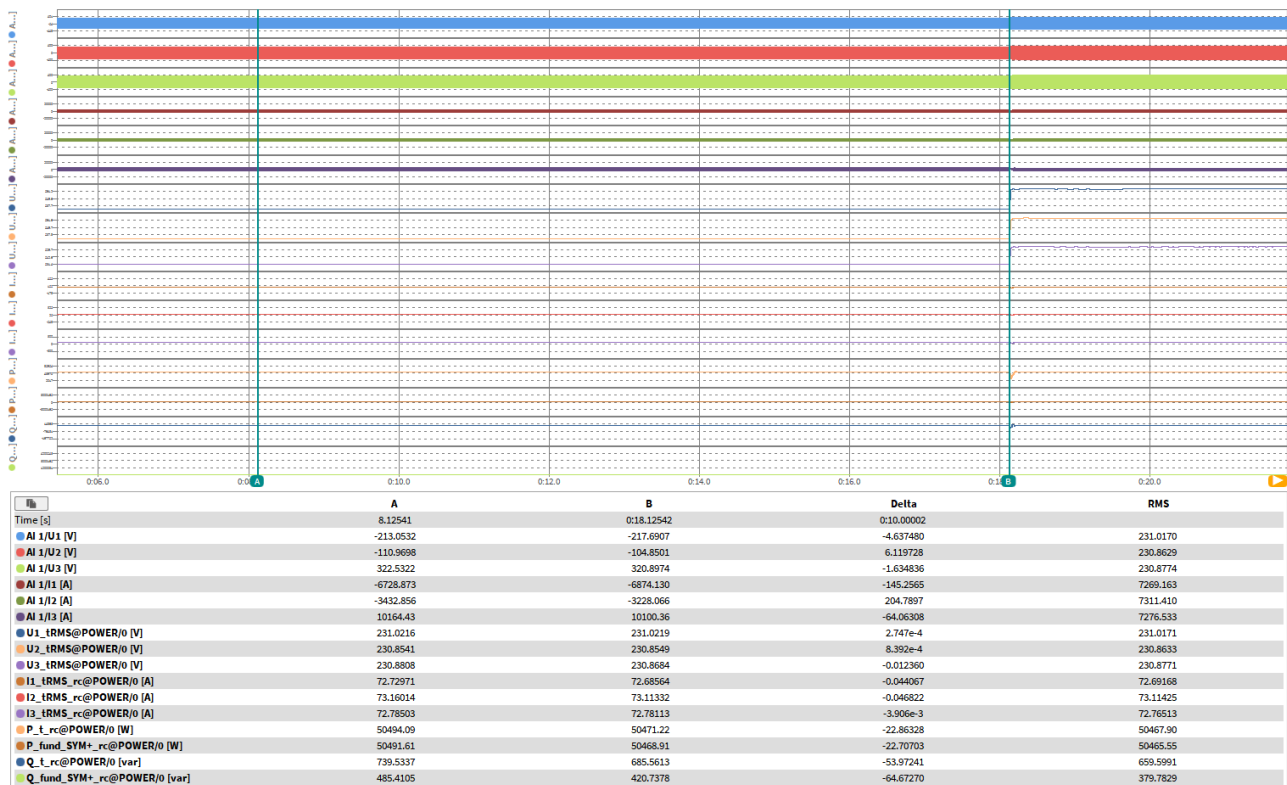

t1-10s to t1



	A	B	Delta	RMS
Time [s]	0:18.12351	1:18.12812	1:00.00462	
AI 1/U1 [V]	-317.6241	0.564814	318.1889	265.3689
AI 1/U2 [V]	90.21235	-322.2189	-412.4313	265.2471
AI 1/U3 [V]	226.4955	324.2297	97.73422	265.2746
AI 1/I1 [A]	-10068.76	93.95143	10162.71	6334.971
AI 1/I2 [A]	3015.211	-7819.615	-10834.83	6364.060
AI 1/I3 [A]	7055.853	7725.225	669.3721	6339.376
U1_rms@POWER/0 [V]	231.0219	265.1796	34.15776	265.3510
U2_rms@POWER/0 [V]	230.8549	265.3524	34.49748	265.2317
U3_rms@POWER/0 [V]	230.8684	265.3703	34.50191	265.2505
I1_rms@POWER/0 [A]	72.65781	63.37499	-9.282818	63.35204
I2_rms@POWER/0 [A]	73.11150	63.66270	-9.448795	63.64387
I3_rms@POWER/0 [A]	72.76804	63.42793	-9.340111	63.39375
P_t_rc@POWER/0 [W]	50461.35	50527.66	66.30859	50501.07
P_fund_SYM+_rc@POWER/0 [W]	50499.04	50525.83	66.79688	50499.47
Q_t_rc@POWER/0 [var]	685.8837	556.6214	-129.2623	870.4065
Q_fund_SYM+_rc@POWER/0 [var]	417.9448	292.0563	-125.8885	510.1919

t1 to t2

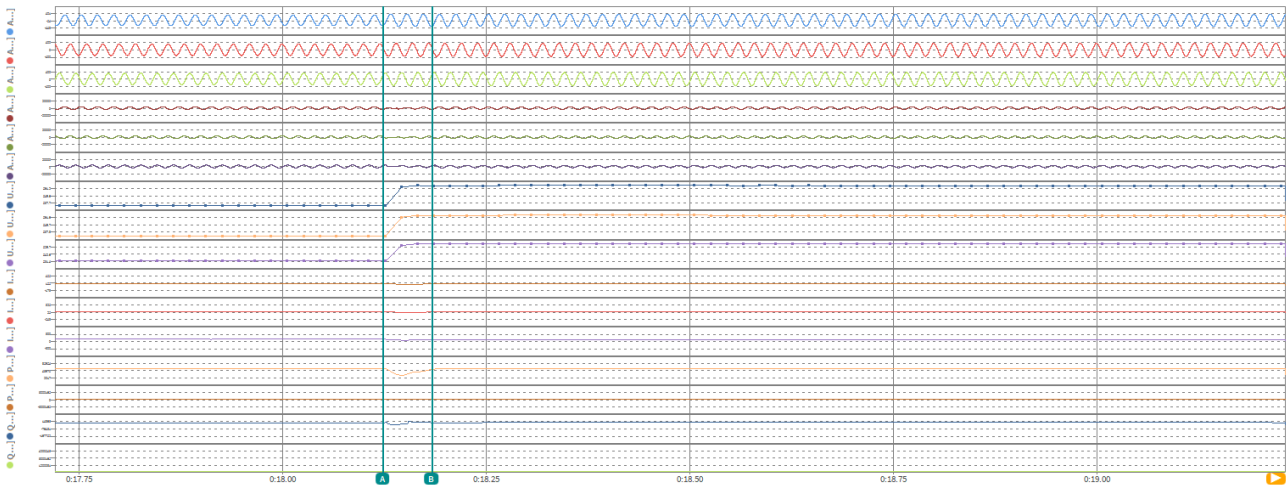

	A	B	Delta	RMS
Time [s]	0:18.12351	0:18.18351	0.06000	
AI 1/U1 [V]	-317.6241	-368.5708	-50.94672	263.2427
AI 1/U2 [V]	90.21235	110.0705	19.85812	263.1898
AI 1/U3 [V]	226.4955	257.7446	31.24905	260.4748
AI 1/I1 [A]	-10068.76	-9704.910	363.8506	4693.209
AI 1/I2 [A]	3015.211	2903.035	-112.1759	4532.761
AI 1/I3 [A]	7055.853	6803.415	-252.4376	4846.512
U1_rms@POWER/0 [V]	231.0219	265.5552	34.53332	248.4611
U2_rms@POWER/0 [V]	230.8549	264.9425	34.08757	247.8781
U3_rms@POWER/0 [V]	230.8684	265.2441	34.37572	247.8789
I1_rms@POWER/0 [A]	72.65781	57.99439	-14.67342	50.02937
I2_rms@POWER/0 [A]	73.11150	58.11374	-14.99775	49.05181
I3_rms@POWER/0 [A]	72.76804	56.44336	-16.32468	51.08662
P_t_rc@POWER/0 [W]	50461.35	45320.55	-5140.801	34108.60
P_fund_SYM+_rc@POWER/0 [W]	50499.04	45297.73	-5161.309	34335.55
Q_t_rc@POWER/0 [var]	685.8837	-6582.204	-7268.088	15766.98
Q_fund_SYM+_rc@POWER/0 [var]	417.9448	-185.1548	-603.0996	1975.562

t1+60ms

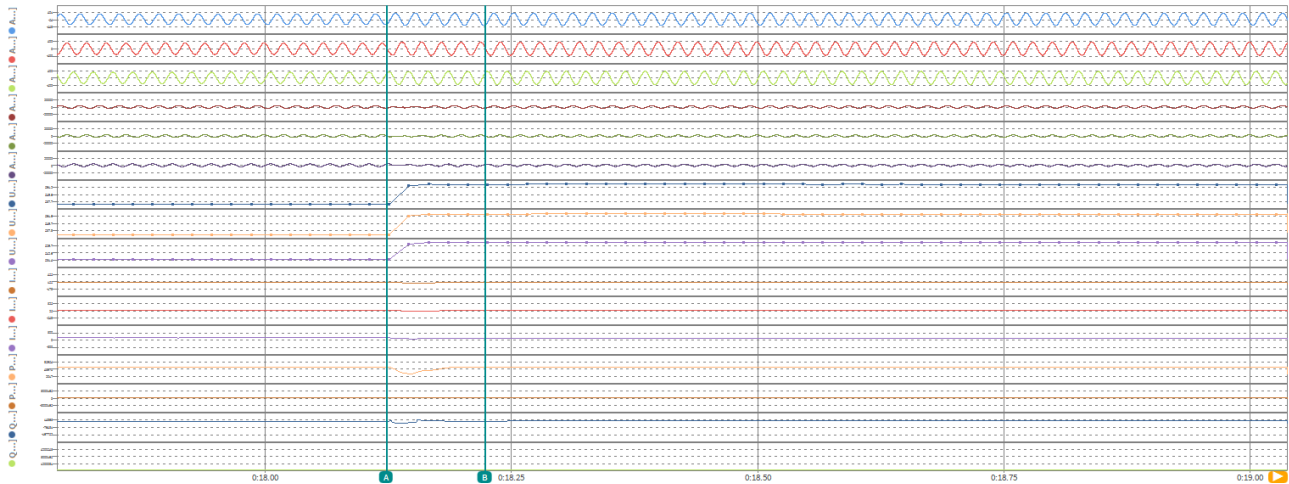

	A	B	Delta	RMS
Time [s]	0:18.12351	0:18.22366	0.10015	
AI 1/U1 [V]	-317.6241	-362.4554	-44.83128	264.0733
AI 1/U2 [V]	90.21235	93.57310	3.360748	263.8125
AI 1/U3 [V]	226.4955	268.2467	41.75115	262.2804
AI 1/I1 [A]	-10068.76	-8357.177	1711.583	5530.479
AI 1/I2 [A]	3015.211	2140.846	-874.3644	5458.121
AI 1/I3 [A]	7055.853	6214.605	-841.2481	5599.028
U1_IRMS@POWER/0 [V]	231.0219	265.2194	34.19749	254.1803
U2_IRMS@POWER/0 [V]	230.8549	265.1264	34.27144	253.6229
U3_IRMS@POWER/0 [V]	230.9684	264.9667	34.09825	253.7820
I1_IRMS@POWER/0 [A]	72.65781	64.94165	-7.716156	56.50394
I2_IRMS@POWER/0 [A]	73.11150	64.80282	-8.308678	55.96566
I3_IRMS@POWER/0 [A]	72.76804	64.50698	-8.261055	56.95185
P_t_rc@POWER/0 [W]	50461.35	51382.96	921.6133	41906.87
P_fund_SYM+rc@POWER/0 [W]	50459.04	51375.78	916.7461	42013.70
Q_t_rc@POWER/0 [var]	685.8837	-3081.437	-3767.321	12522.01
Q_fund_SYM+rc@POWER/0 [var]	417.9448	-1645.355	-2063.300	1692.084

t1+100ms

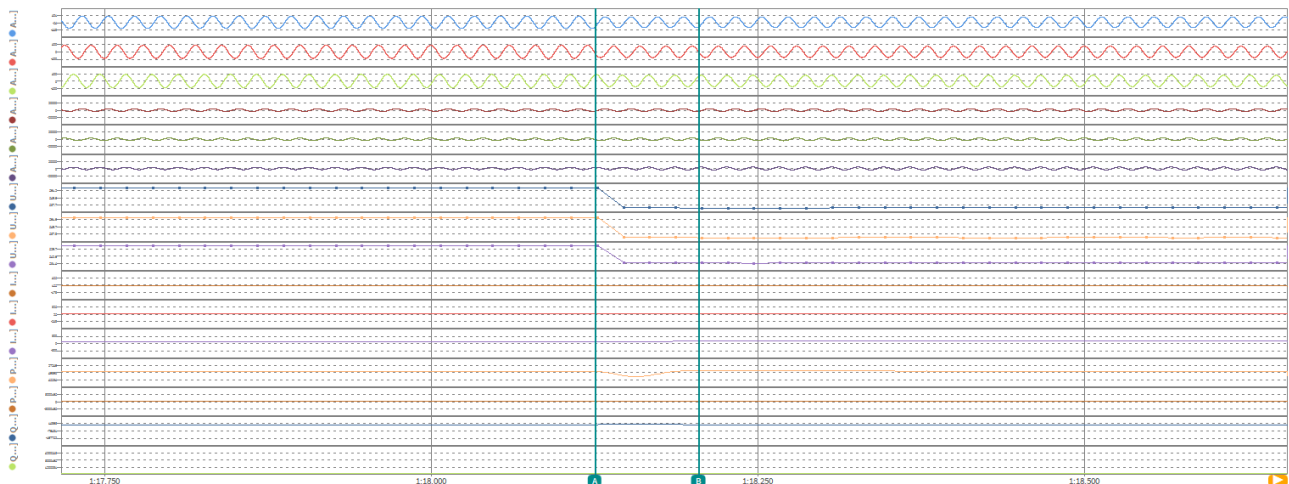

	A	B	Delta	RMS
Time [s]	1:18.12530	1:18.20468	0.07938	
AI 1/U1 [V]	-300.1783	-291.8112	8.367062	231.4591
AI 1/U2 [V]	-50.17543	14.69922	64.87465	232.6143
AI 1/U3 [V]	347.3821	273.8853	-73.49682	233.2331
AI 1/I1 [A]	-7234.655	-8987.294	-1752.639	6970.817
AI 1/I2 [A]	-1041.577	-119.2785	922.2985	7007.687
AI 1/I3 [A]	8276.055	9106.277	830.2212	6938.970
U1_IRMS@POWER/0 [V]	265.3656	231.0867	-34.27890	245.4210
U2_IRMS@POWER/0 [V]	265.2558	231.0170	-34.23885	245.3620
U3_IRMS@POWER/0 [V]	265.2789	230.9950	-34.28384	245.3967
I1_IRMS@POWER/0 [A]	63.37986	74.31116	10.93130	68.20392
I2_IRMS@POWER/0 [A]	63.66314	74.01958	10.35644	68.59636
I3_IRMS@POWER/0 [A]	63.44416	74.25007	10.80591	68.26291
P_t_rc@POWER/0 [W]	50534.13	51342.50	808.3711	48431.70
P_fund_SYM+rc@POWER/0 [W]	50532.23	51340.30	808.0742	48444.67
Q_t_rc@POWER/0 [var]	555.7037	-1445.282	-2000.986	2689.746
Q_fund_SYM+rc@POWER/0 [var]	292.5115	-966.3010	-1258.813	1211.738

Active power rising time

Condition						Measurement
No.	Parameter	Phase ref.	Time ref.	unit		
General Info.	0	Test number	--	--	--	7.2
	1	Date	--	--	dd.mm.yyyy	15.05.2025
	2	Time (start of test)	--	--	hh:mm:ss.f	10:35:26
	3	Fault type (phase)	--	--		A
	4	Setting voltage depth	Line to line	--	p.u.	1.15
	5	Setting dip duration		--		60000
	6	Point of fault entry	Total	--	ms	18451
	7	Point of fault clearance	Total	--	ms	78456
	8	Fault duration in empty load test	Total	--	ms	60004
	9	Voltage depth/height in empty load test	Total	t1+100ms to t2 and t1-10s to t1	p.u.	1.150
10	Pos.		p.u.		1.000	
Before dip <t1	11	Voltage	Line to neutral	t1-100s to t1	p.u.	1.001
	12	Current	Pos.	t1-500ms to t1-100ms	p.u.	0.499
	13	Active power	Total	t1-10s to t1	p.u.	0.499
	14		Pos.			0.499
	15	Reactive power	Total	t1-10s to t1	p.u.	0.009
	16		Pos.			0.002
17	Cos ϕ	--	t1-10s to t1	--	0.999	
During dip t1 to t2	18	Voltage	Line to neutral	t1+100ms to t2-20ms	p.u.	1.151
	19	Line current	Phase 1	t1+60ms	p.u.	0.480
	20		Phase 2			0.483
	21		Phase 3			0.479
	22	Line current	Phase 1	t1+100ms	p.u.	0.440
	23		Phase 2			0.443
	24		Phase 3			0.441
	25	Active power	Total	t1+100ms to t2-20ms	p.u.	0.504
26	Pos.		0.503			
After dip > t2	27	Voltage	Line to neutral	t2+3s to t2+10s	p.u.	1.001
	28	Active power	Total	t2+3s to t2+10s	p.u.	0.499
	29		Pos.			0.499
	39	Active power rising time	Pos.	--	s	0.059
	31	Reactive power	Total	t2+3s to t2+10s	p.u.	0.009
	32		Pos.			0.002
	33	Reactive power rising time	Pos.	--	s	--
	34	PGU does not disconnect from grid till 60s after fault	--	t2 to t2+60s	Yes / No	Yes

Test No. 7.2 idle test

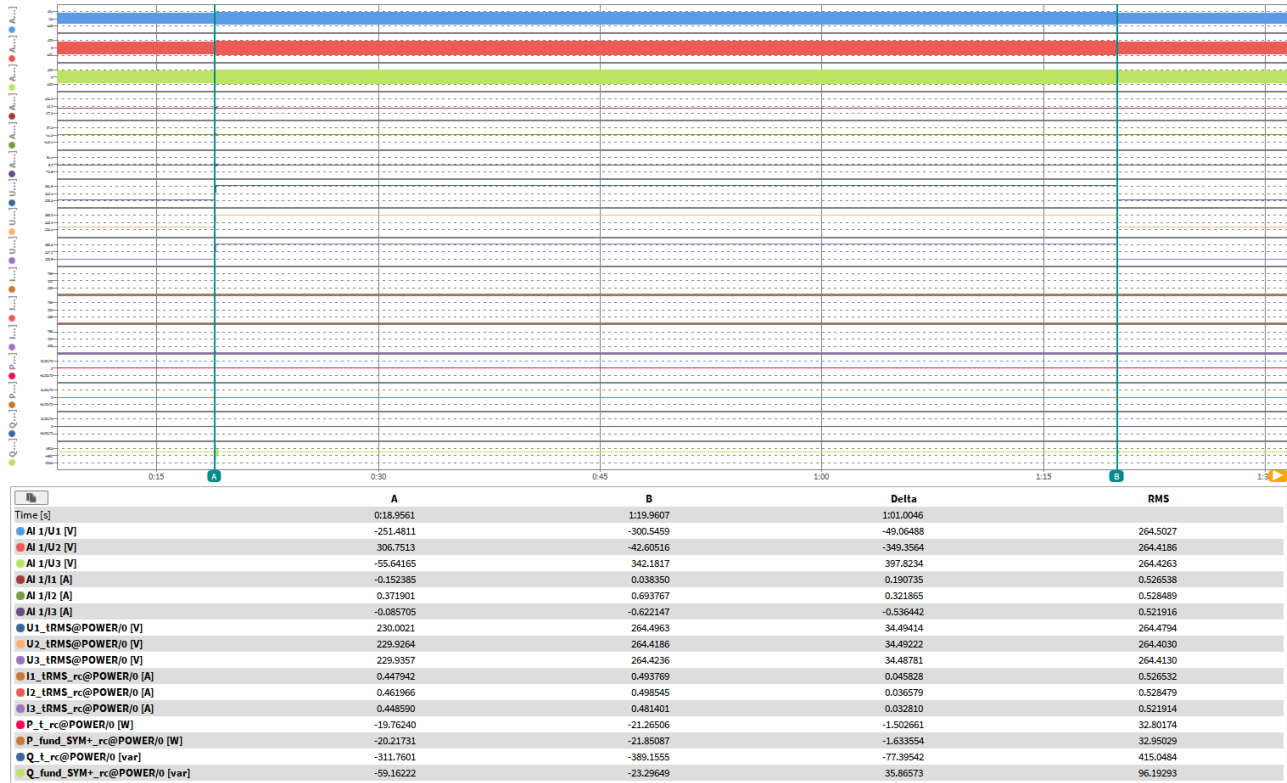

Test No. 7.2 with PGU

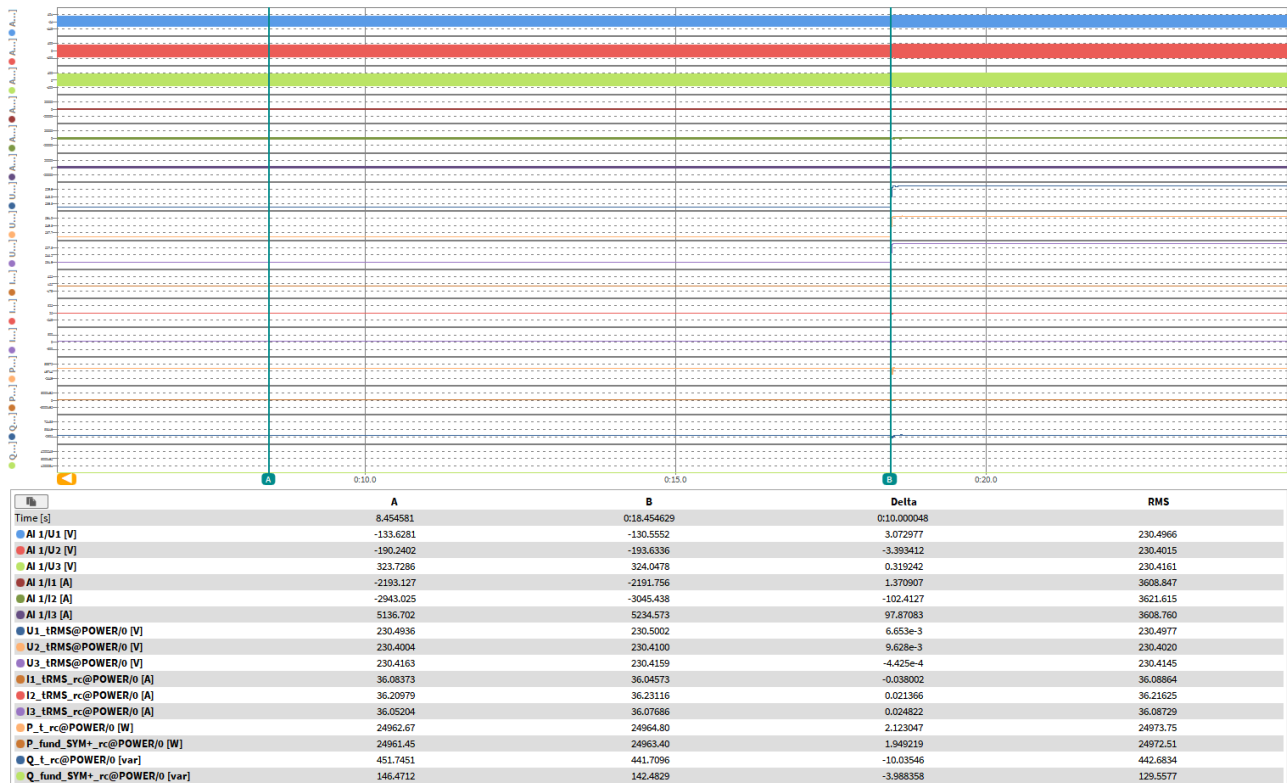

t1-10s to t1



	A	B	Delta	RMS
Time [s]	0:18.451587	1:18.456353	1:00.004766	
AI 1/U1 [V]	-320.5915	0.999928	321.5914	264.9404
AI 1/U2 [V]	107.9352	-317.6902	-425.6253	264.8221
AI 1/U3 [V]	212.1625	318.3503	106.1878	264.8576
AI 1/I1 [A]	-5014.155	64.92397	5079.079	3142.312
AI 1/I2 [A]	1802.399	-4075.322	-5877.722	3151.817
AI 1/I3 [A]	3210.399	4007.564	797.1645	3141.694
U1_rms@POWER/0 [V]	230.5002	264.7350	34.23476	264.9222
U2_rms@POWER/0 [V]	230.4100	264.9184	34.50832	264.8070
U3_rms@POWER/0 [V]	230.4159	264.9525	34.53662	264.8335
I1_rms@POWER/0 [A]	36.07016	31.42344	-4.646715	31.42421
I2_rms@POWER/0 [A]	36.23877	31.51041	-4.728355	31.51989
I3_rms@POWER/0 [A]	36.13744	31.40826	-4.729181	31.41693
P_t_rc@POWER/0 [W]	24987.04	24985.18	-1.855469	24987.50
P_fund_SYM+_rc@POWER/0 [W]	24985.69	24984.20	-1.494141	24986.52
Q_t_rc@POWER/0 [var]	441.6494	425.1662	-16.48322	525.7662
Q_fund_SYM+_rc@POWER/0 [var]	140.5787	114.0047	-26.57397	176.1392

t1 to t2

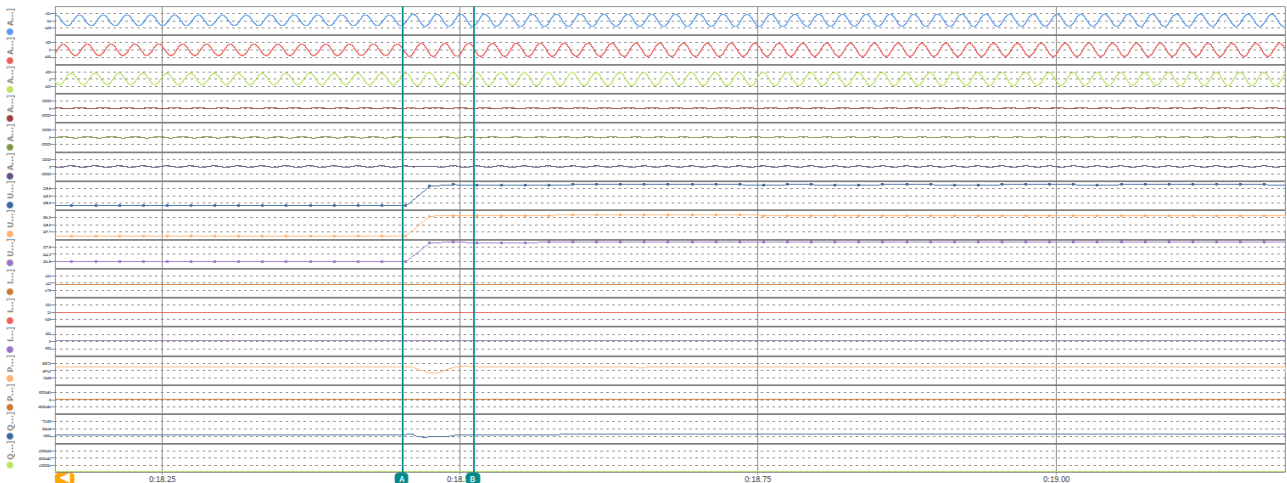

	A	B	Delta	RMS
Time [s]	0:18.451587	0:18.511636	0:06.0049	
AI 1/U1 [V]	-320.5915	-367.1966	-46.60511	262.5758
AI 1/U2 [V]	107.9352	113.3275	5.392313	262.9667
AI 1/U3 [V]	212.1625	253.2983	41.13579	260.3760
AI 1/I1 [A]	-5014.155	-4930.863	83.29154	2984.723
AI 1/I2 [A]	1802.399	1674.920	-127.4705	3041.768
AI 1/I3 [A]	3210.399	3256.426	46.02671	2907.184
U1_rms@POWER/0 [V]	230.5002	265.0135	34.51326	247.7812
U2_rms@POWER/0 [V]	230.4100	264.8549	34.44484	247.6436
U3_rms@POWER/0 [V]	230.4159	264.7887	34.37283	247.8544
I1_rms@POWER/0 [A]	36.07016	34.69305	-1.377110	30.22102
I2_rms@POWER/0 [A]	36.23877	34.86367	-1.375092	30.86239
I3_rms@POWER/0 [A]	36.13744	34.64136	-1.496086	29.42691
P_t_rc@POWER/0 [W]	24987.04	27507.41	2520.367	21252.64
P_fund_SYM+_rc@POWER/0 [W]	24985.69	27503.05	2517.355	21306.62
Q_t_rc@POWER/0 [var]	441.6494	-2221.164	-2662.814	8752.611
Q_fund_SYM+_rc@POWER/0 [var]	140.5787	-623.7247	-764.3035	2204.917

t1+60ms

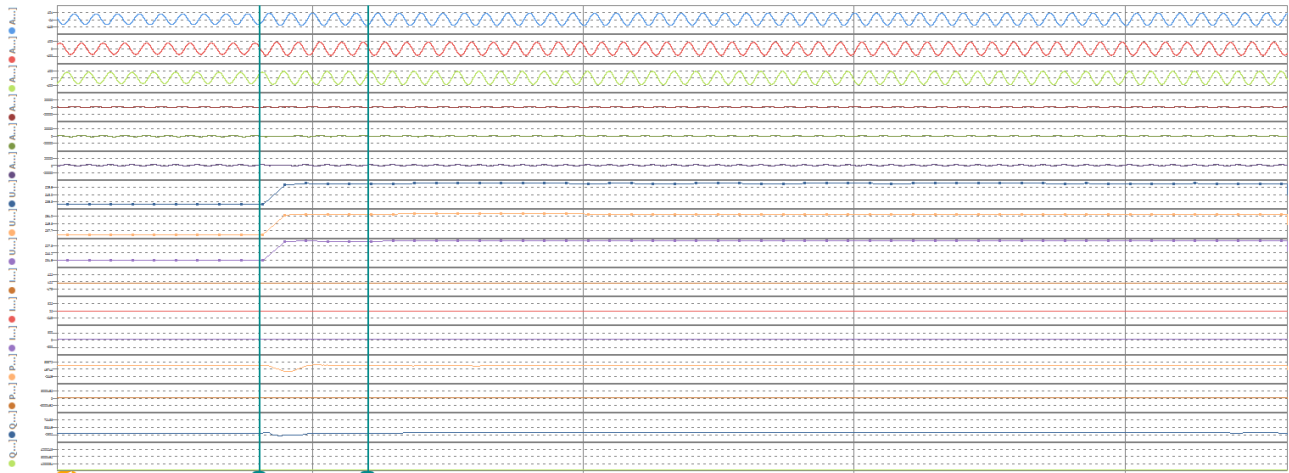

	A	B	Delta	RMS
Time [s]	0:18.451587	0:18.551653	0.100066	
AI 1/U1 [V]	-320.5915	-367.5854	-46.99397	263.3807
AI 1/U2 [V]	107.9352	114.2042	6.268978	263.5946
AI 1/U3 [V]	212.1625	252.8238	40.66134	262.0589
AI 1/I1 [A]	-5014.155	-4318.342	695.8127	3078.912
AI 1/I2 [A]	1802.399	1325.884	-476.5153	3119.150
AI 1/I3 [A]	3210.399	2994.643	-215.7569	3043.077
U1_IRMS@POWER/0 [V]	230.5002	264.6653	34.16502	253.5717
U2_IRMS@POWER/0 [V]	230.4100	264.5952	34.18513	253.5605
U3_IRMS@POWER/0 [V]	230.4159	264.6468	34.23093	253.5757
I1_IRMS@POWER/0 [A]	36.07016	31.78216	-4.287996	31.30227
I2_IRMS@POWER/0 [A]	36.23877	32.04714	-4.191628	31.75395
I3_IRMS@POWER/0 [A]	36.13744	31.84980	-4.287642	30.88514
P_t_rc@POWER/0 [W]	24987.04	25220.47	233.4316	23289.42
P_fund_SYM+rc@POWER/0 [W]	24985.69	25218.65	232.9629	23317.87
Q_t_rc@POWER/0 [var]	441.6494	-2125.271	-2566.921	6927.312
Q_fund_SYM+rc@POWER/0 [var]	140.5787	-1780.963	-1921.541	1912.755

t1+100ms

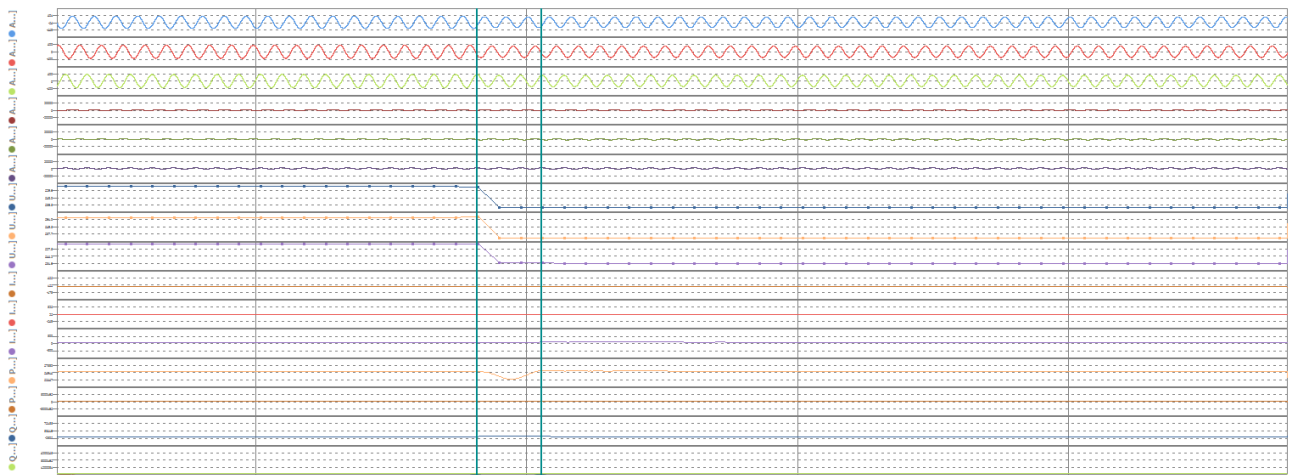

	A	B	Delta	RMS
Time [s]	1:18.453647	1:18.513475	0.059828	
AI 1/U1 [V]	-281.5986	-256.6507	24.94788	231.3832
AI 1/U2 [V]	-76.18499	-46.72432	29.46067	231.9432
AI 1/U3 [V]	356.3214	301.7264	-54.59500	233.6453
AI 1/I1 [A]	-3402.350	-4268.894	-866.5443	3463.575
AI 1/I2 [A]	-850.4368	-576.1481	274.2887	3459.734
AI 1/I3 [A]	4254.029	4641.910	387.8806	3434.475
U1_IRMS@POWER/0 [V]	264.9513	230.8147	-34.13660	248.4187
U2_IRMS@POWER/0 [V]	264.8284	230.6490	-34.17947	248.3469
U3_IRMS@POWER/0 [V]	264.8535	230.7303	-34.12315	248.3658
I1_IRMS@POWER/0 [A]	31.42396	36.79651	5.332554	33.57506
I2_IRMS@POWER/0 [A]	31.51287	36.66289	5.150019	33.69749
I3_IRMS@POWER/0 [A]	31.41049	36.55953	5.149038	33.56699
P_t_rc@POWER/0 [W]	24986.84	25341.30	354.4629	23920.03
P_fund_SYM+rc@POWER/0 [W]	24985.71	25339.64	353.9336	23937.25
Q_t_rc@POWER/0 [var]	423.0644	893.5190	470.4546	2013.058
Q_fund_SYM+rc@POWER/0 [var]	113.9225	388.2574	274.3348	969.0213

Active power rising time

Condition						Measurement
No.	Parameter	Phase ref.	Time ref.	unit		
General Info.	0	Test number	--	--	--	7.3
	1	Date	--	--	dd.mm.yyyy	26.06.2025
	2	Time (start of test)	--	--	hh:mm:ss.f	15:01:06
	3	Fault type (phase)	--	--		D1
	4	Setting voltage depth	Line to line	--	p.u.	1.15
	5	Setting dip duration		--		60000
	6	Point of fault entry	Total	--	ms	19105
	7	Point of fault clearance	Total	--	ms	79126
	8	Fault duration in empty load test	Total	--	ms	60019
	9	Voltage depth/height in empty load test	Total	t1+100ms to t2 and t1-10s to t1	p.u.	1.150
10	Pos.		p.u.		1.000	
Before dip <t1	11	Voltage	Line to neutral	t1-100s to t1	p.u.	1.004
	12	Current	Pos.	t1-500ms to t1-100ms	p.u.	1.006
	13	Active power	Total	t1-10s to t1	p.u.	1.009
	14		Pos.			1.009
	15	Reactive power	Total	t1-10s to t1	p.u.	0.020
	16		Pos.			0.007
17	Cosφ	--	t1-10s to t1	--	0.999	
During dip t1 to t2	18	Voltage	Line to neutral	t1+100ms to t2-20ms	p.u.	1.153
	19	Line current	Phase 1	t1+60ms	p.u.	0.981
	20		Phase 2			0.994
	21		Phase 3			0.994
	22	Line current	Phase 1	t1+100ms	p.u.	0.903
	23		Phase 2			0.925
	24		Phase 3			0.927
	25	Active power	Total	t1+100ms to t2-20ms	p.u.	0.995
26	Pos.		0.987			
After dip > t2	27	Voltage	Line to neutral	t2+3s to t2+10s	p.u.	1.004
	28	Active power	Total	t2+3s to t2+10s	p.u.	1.009
	29		Pos.			1.008
	39	Active power rising time	Pos.	--	s	0.182
	31	Reactive power	Total	t2+3s to t2+10s	p.u.	0.011
	32		Pos.			0.007
	33	Reactive power rising time	Pos.	--	s	--
	34	PGU does not disconnect from grid till 60s after fault	--	t2 to t2+60s	Yes / No	Yes

Test No. 7.3 idle test

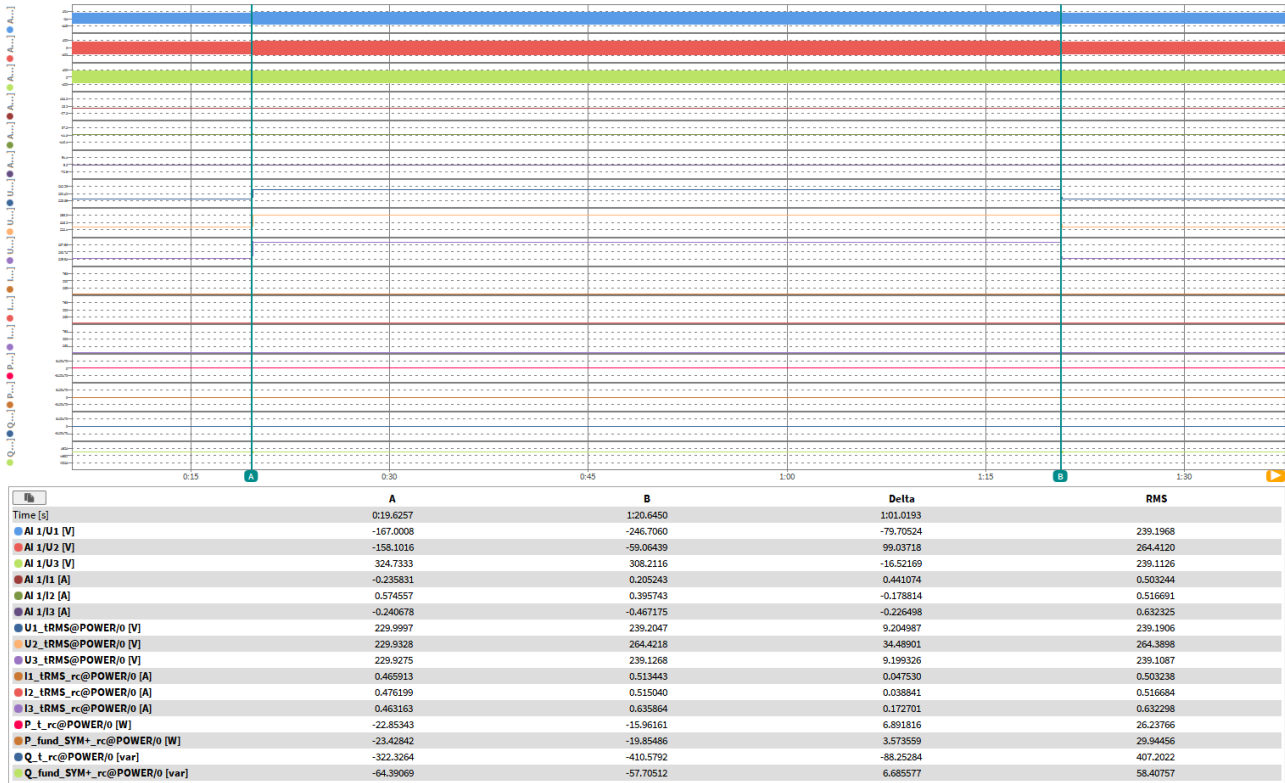

Test No. 7.3 with PGU

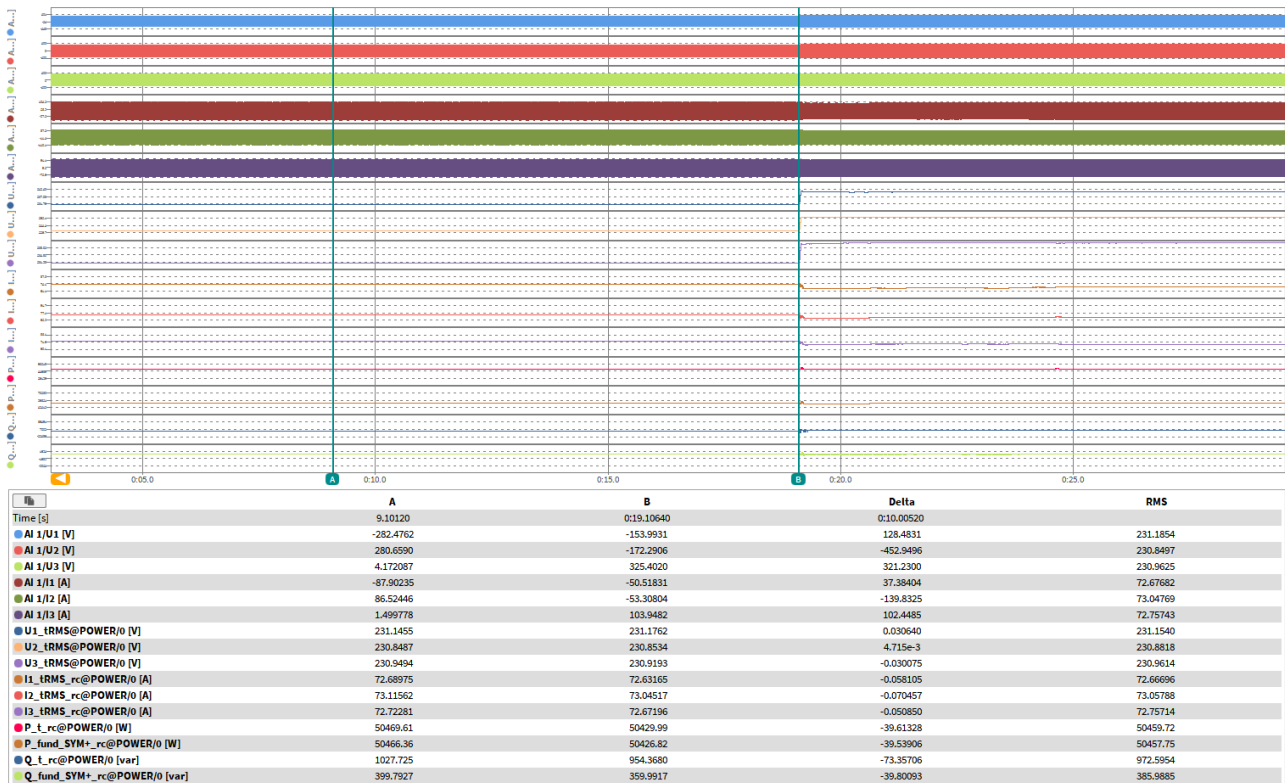

t1-10s to t1

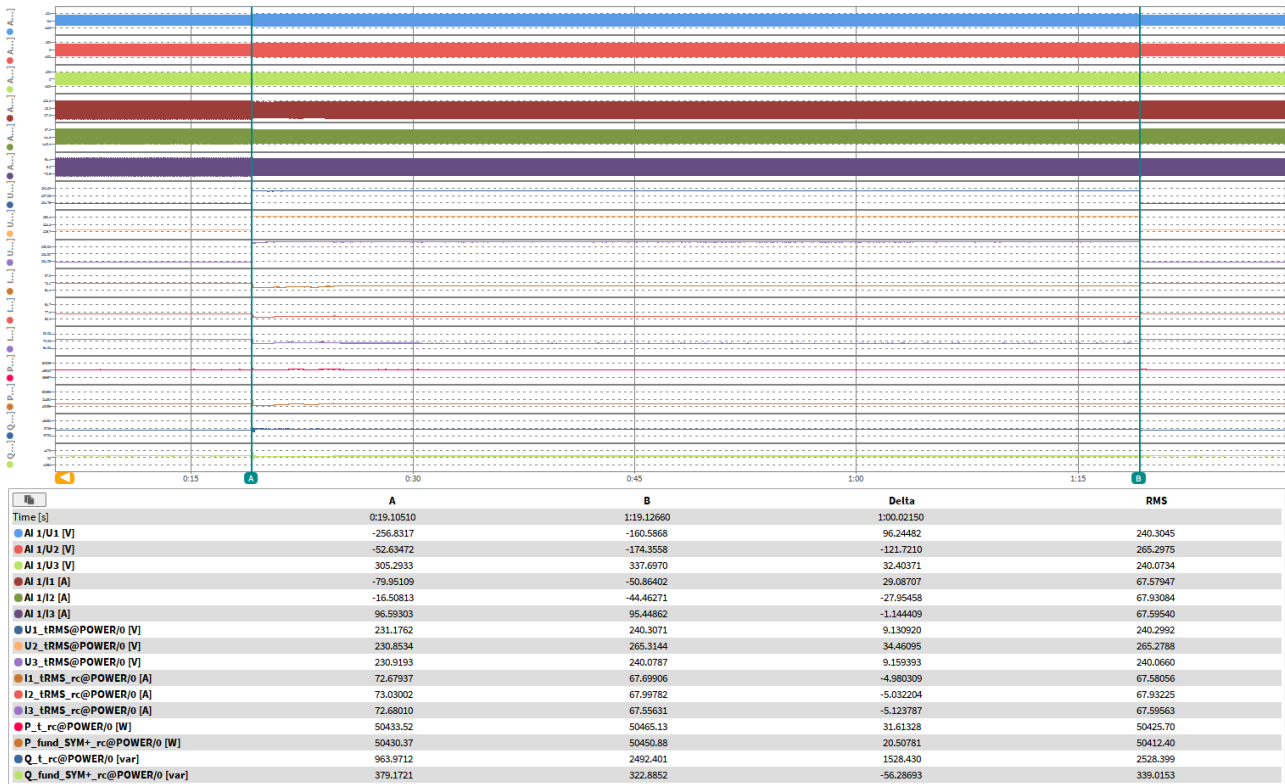

t1 to t2

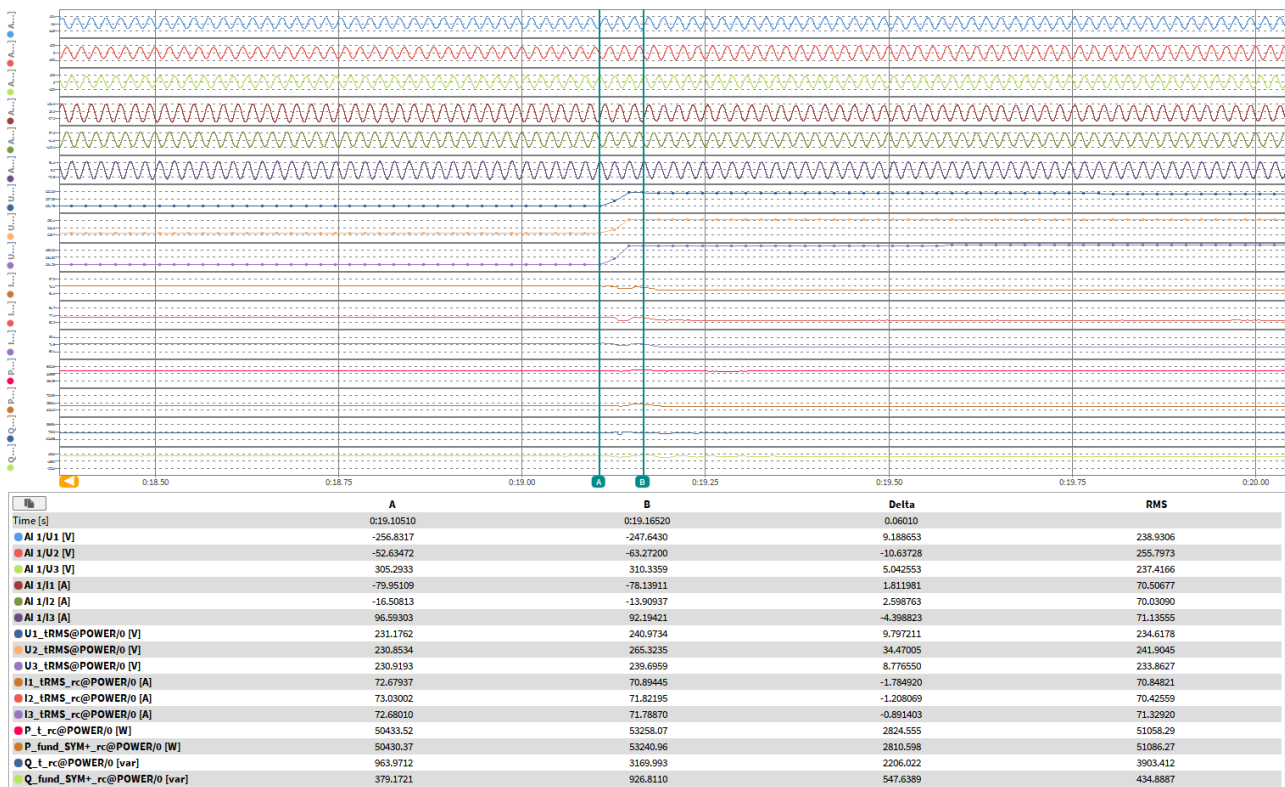

t1+60ms

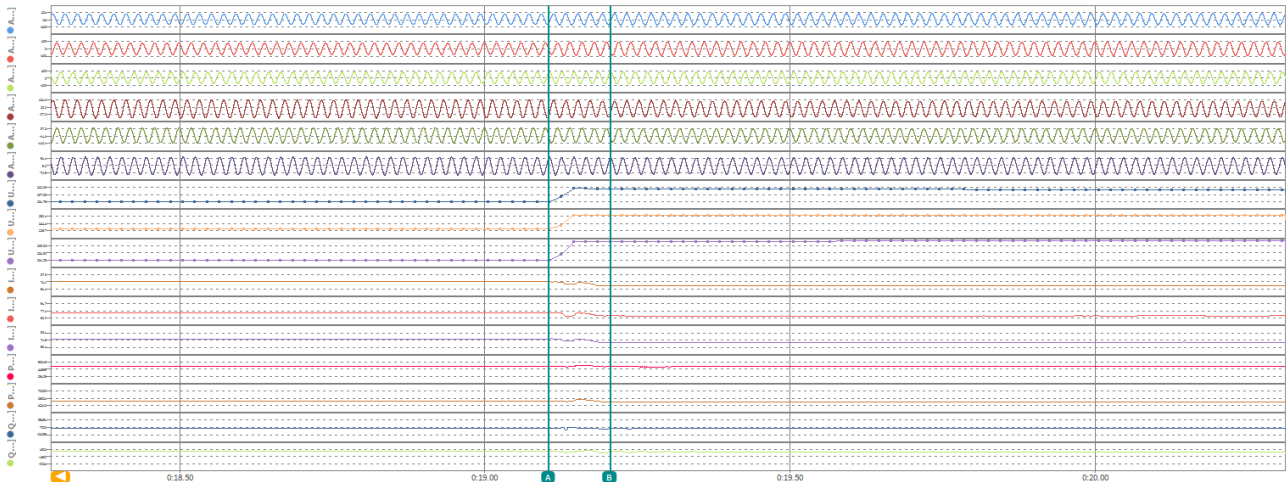

	A	B	Delta	RMS
Time [s]	0:19.10510	0:19.20560	0.10050	
AI 1/U1 [V]	-256.8317	-215.2064	41.62526	239.5915
AI 1/U2 [V]	-52.63472	-108.1529	-55.51815	259.0930
AI 1/U3 [V]	305.2933	323.7875	18.49413	238.6796
AI 1/I1 [A]	-79.95109	-68.05400	11.89709	68.61242
AI 1/I2 [A]	-16.50813	-26.27138	-9.763241	68.77829
AI 1/I3 [A]	96.59303	94.41150	-2.181530	69.85363
U1_IRMS@POWER/0 [V]	231.1762	240.6487	9.472519	236.6974
U2_IRMS@POWER/0 [V]	230.8534	265.1046	34.25111	249.9289
U3_IRMS@POWER/0 [V]	230.9193	239.5446	8.625229	235.7915
I1_IRMS_rc@POWER/0 [A]	72.67937	65.23019	-7.449181	69.43294
I2_IRMS_rc@POWER/0 [A]	73.03002	66.81688	-6.213142	69.61426
I3_IRMS_rc@POWER/0 [A]	72.68010	66.98299	-5.697113	70.21633
P_fund_SYM+rc@POWER/0 [W]	50433.52	49386.47	-1047.047	50887.00
P_fund_SYM+rc@POWER/0 [W]	50430.37	49362.76	-1067.605	50897.21
Q_fund_SYM+rc@POWER/0 [var]	963.9712	-2759.214	-3723.186	3581.205
Q_fund_SYM+rc@POWER/0 [var]	379.1721	36.97252	-342.1996	527.7019

t1+100ms

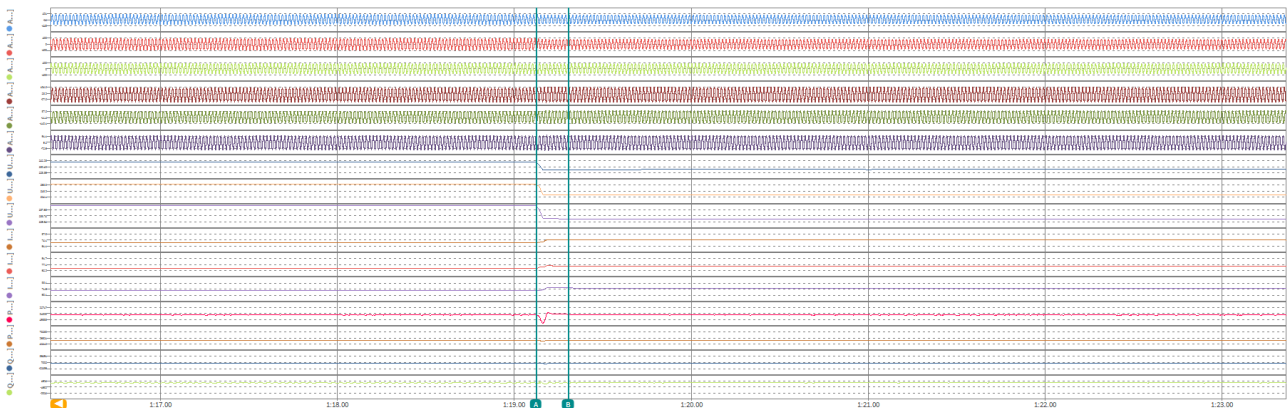

	A	B	Delta	RMS
Time [s]	1:19.12480	1:19.30690	0.18210	
AI 1/U1 [V]	-293.1154	-143.4276	149.6878	231.4189
AI 1/U2 [V]	24.22500	-182.6141	-206.8391	233.1287
AI 1/U3 [V]	268.7960	325.6667	56.87070	233.3069
AI 1/I1 [A]	-84.46912	-46.02412	38.44500	72.09343
AI 1/I2 [A]	5.509222	-56.57488	-62.08400	72.35511
AI 1/I3 [A]	79.09311	102.7800	23.68689	72.37573
U1_IRMS@POWER/0 [V]	240.3071	230.8822	-9.424911	233.2446
U2_IRMS@POWER/0 [V]	265.3144	230.9349	-34.37950	240.9003
U3_IRMS@POWER/0 [V]	240.0787	231.2742	-8.804504	233.7371
I1_IRMS_rc@POWER/0 [A]	67.71890	72.91271	5.193810	71.75129
I2_IRMS_rc@POWER/0 [A]	67.99984	73.31009	5.310249	72.32001
I3_IRMS_rc@POWER/0 [A]	67.50597	72.99339	5.487320	71.79666
P_fund_SYM+rc@POWER/0 [W]	50471.26	50636.54	165.2813	50367.66
P_fund_SYM+rc@POWER/0 [W]	50467.29	50634.23	176.9453	50361.88
Q_fund_SYM+rc@POWER/0 [var]	2496.145	599.4755	-1896.669	1341.105
Q_fund_SYM+rc@POWER/0 [var]	331.4109	335.0160	3.605133	412.8106

Active power rising time

Condition						Measurement
No.	Parameter	Phase ref.	Time ref.	unit		
General Info.	0	Test number	--	--	--	7.4
	1	Date	--	--	dd.mm.yyyy	26.06.2025
	2	Time (start of test)	--	--	hh:mm:ss.f	14:58:25
	3	Fault type (phase)	--	--		D1
	4	Setting voltage depth	Line to line	--	p.u.	1.15
	5	Setting dip duration		--		60000
	6	Point of fault entry	Total	--	ms	18485
	7	Point of fault clearance	Total	--	ms	78507
	8	Fault duration in empty load test	Total	--	ms	60019
	9	Voltage depth/height in empty load test	Total	t1+100ms to t2 and t1-10s to t1	p.u.	1.150
10	Pos.		p.u.		1.000	
Before dip <t1	11	Voltage	Line to neutral	t1-100s to t1	p.u.	1.001
	12	Current	Pos.	t1-500ms to t1-100ms	p.u.	0.499
	13	Active power	Total	t1-10s to t1	p.u.	0.499
	14		Pos.			0.499
	15	Reactive power	Total	t1-10s to t1	p.u.	0.007
	16		Pos.			0.002
17	Cos ϕ	--	t1-10s to t1	--	0.999	
During dip t1 to t2	18	Voltage	Line to neutral	t1+100ms to t2-20ms	p.u.	1.151
	19	Line current	Phase 1	t1+60ms	p.u.	0.485
	20		Phase 2			0.485
	21		Phase 3			0.484
	22	Line current	Phase 1	t1+100ms	p.u.	0.466
	23		Phase 2			0.467
	24		Phase 3			0.464
	25	Active power	Total	t1+100ms to t2-20ms	p.u.	0.506
26	Pos.		0.500			
After dip > t2	27	Voltage	Line to neutral	t2+3s to t2+10s	p.u.	1.001
	28	Active power	Total	t2+3s to t2+10s	p.u.	0.499
	29		Pos.			0.499
	39	Active power rising time	Pos.	--	s	0.083
	31	Reactive power	Total	t2+3s to t2+10s	p.u.	0.009
	32		Pos.			0.003
	33	Reactive power rising time	Pos.	--	s	--
	34	PGU does not disconnect from grid till 60s after fault	--	t2 to t2+60s	Yes / No	Yes

Test No. 7.4 idle test

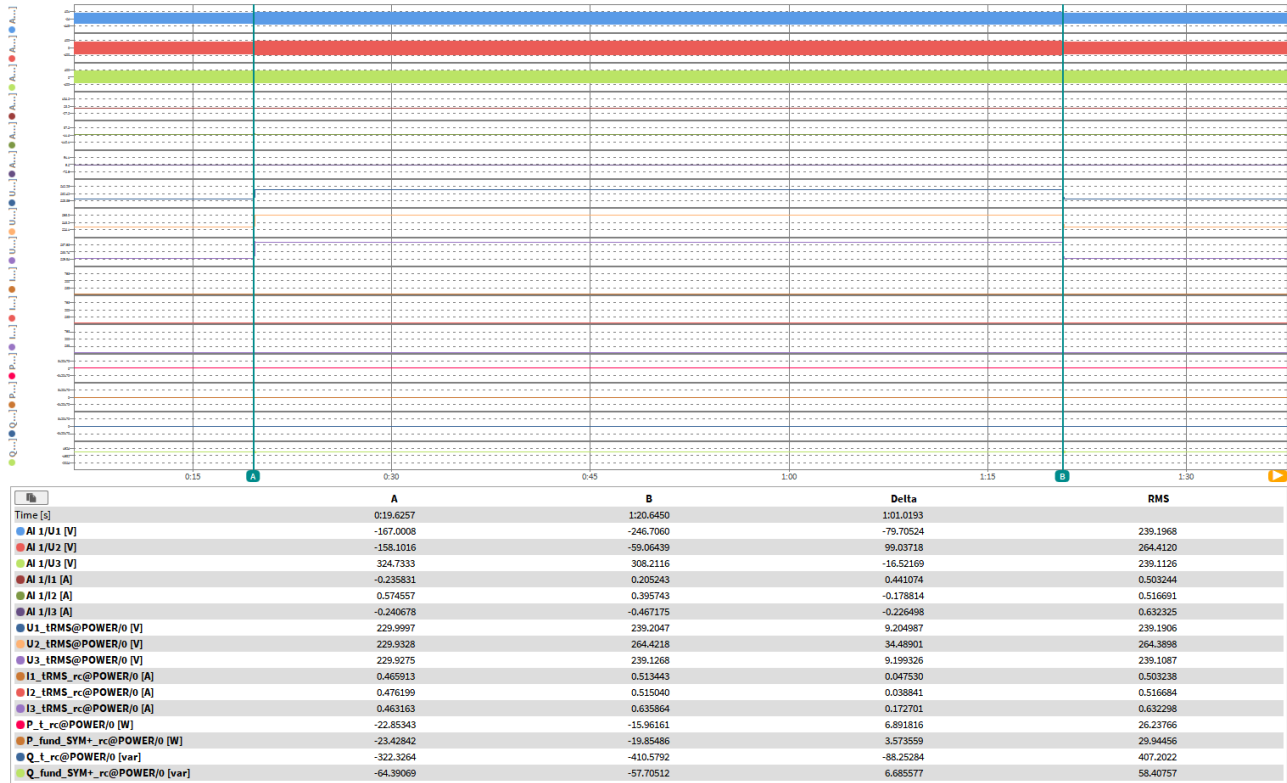

Test No. 7.4 with PGU

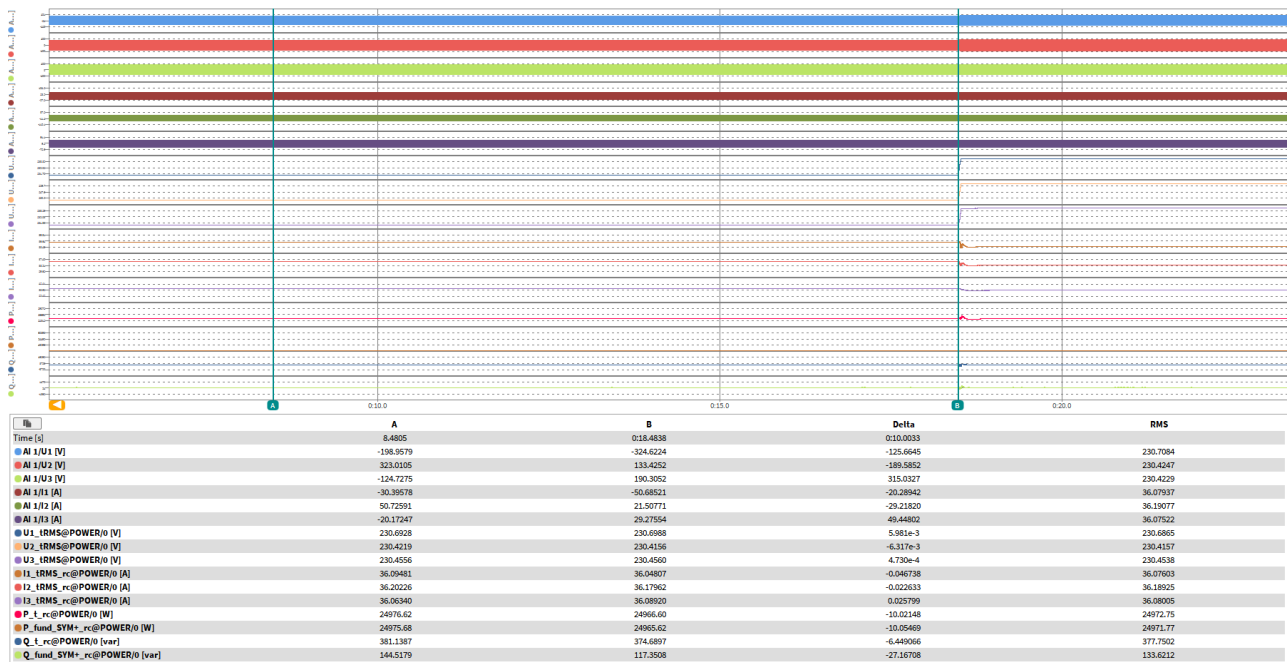

t1-10s to t1

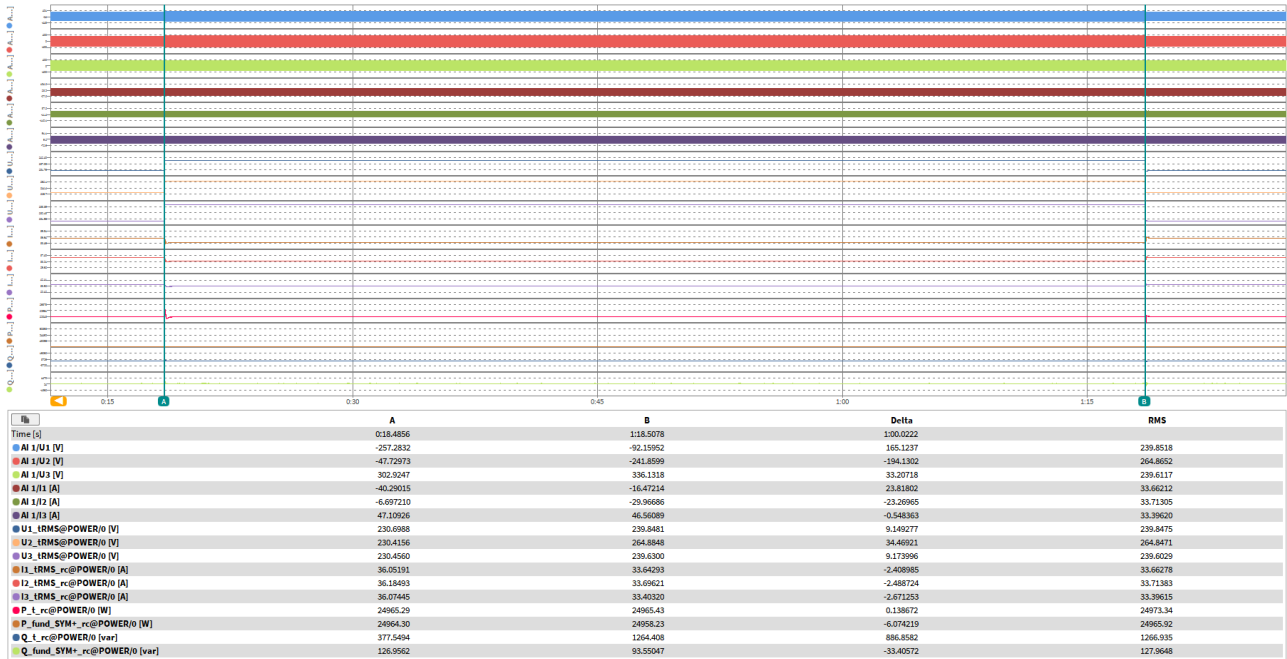

t1 to t2

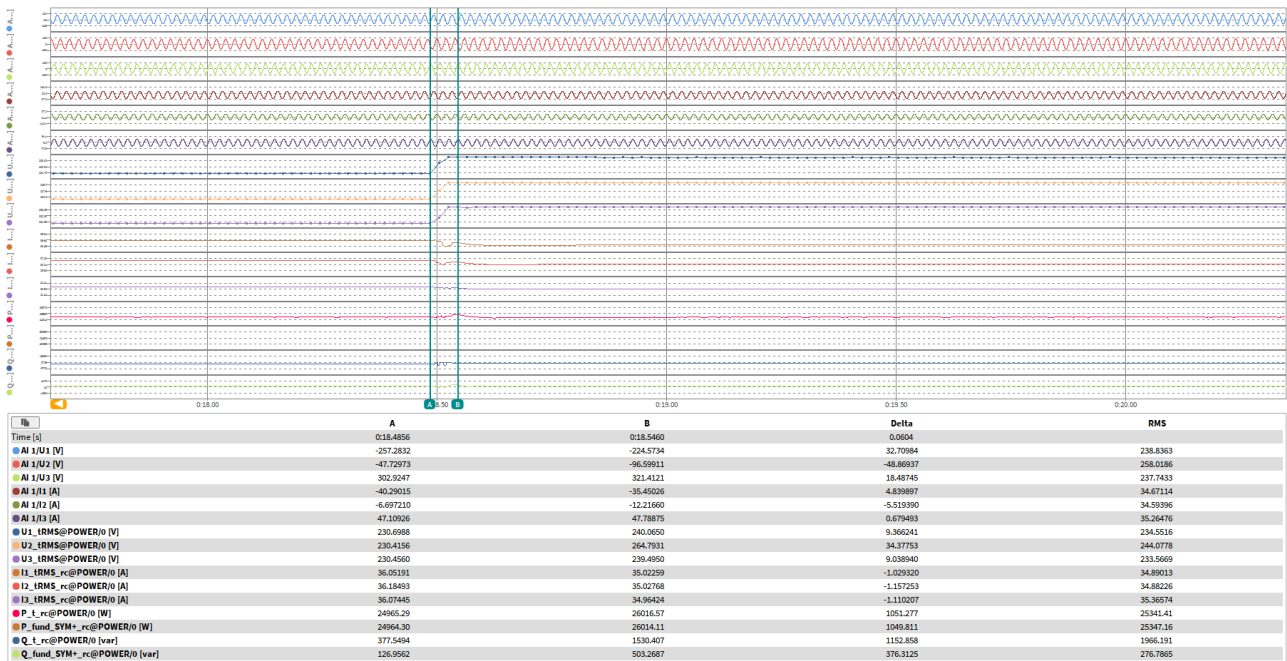

t1+60ms

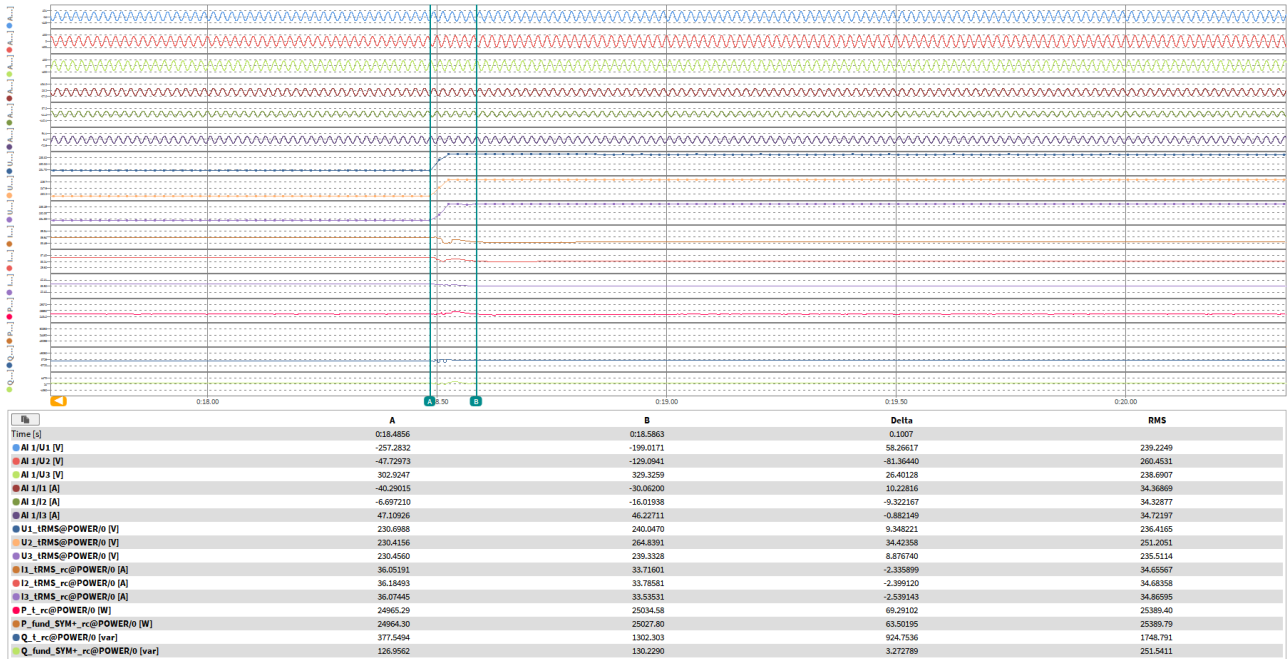

t1+100ms

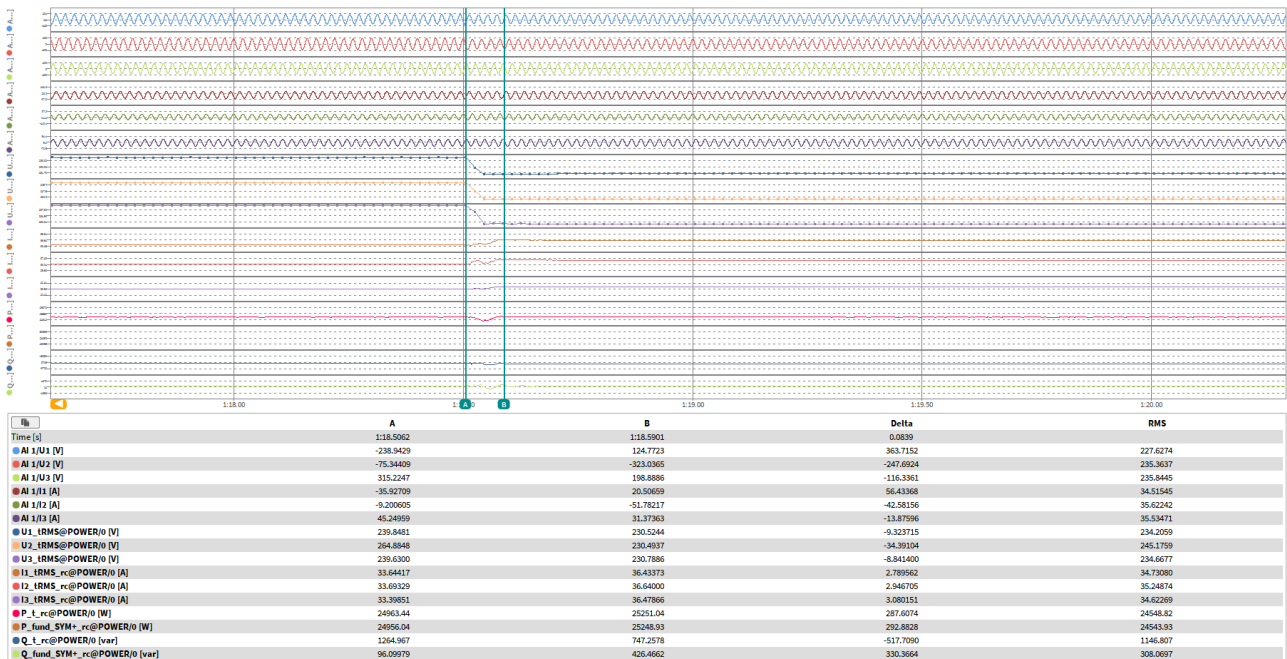

Active power rising time

---END---

PHOTO DOCUMENTATION

CN25NMLN 001 ATTACHMENT 2

for

Solar Inverter

SUN2000-50K-MC0, SUN2000-40K-MC0, SUN2000-
30K-MC0

Huawei Technologies Co., Ltd.



This documentation consists of 5 pages (excluding this cover page)

Model: see cover page



Figure 1. Front view



Figure 2. Back view

Model: see cover page



Figure 3. Terminals view

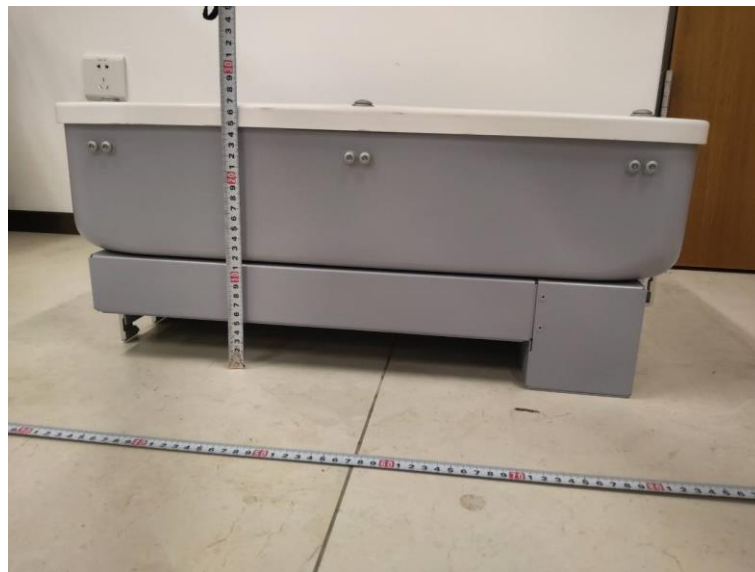

Figure 4. Top view

Model: see cover page



Figure 5. Side view-1



Figure 6. Side view-2

Model: see cover page

Figure 7. Internal view

Figure 8. Top view of Power supply board

Model: see cover page

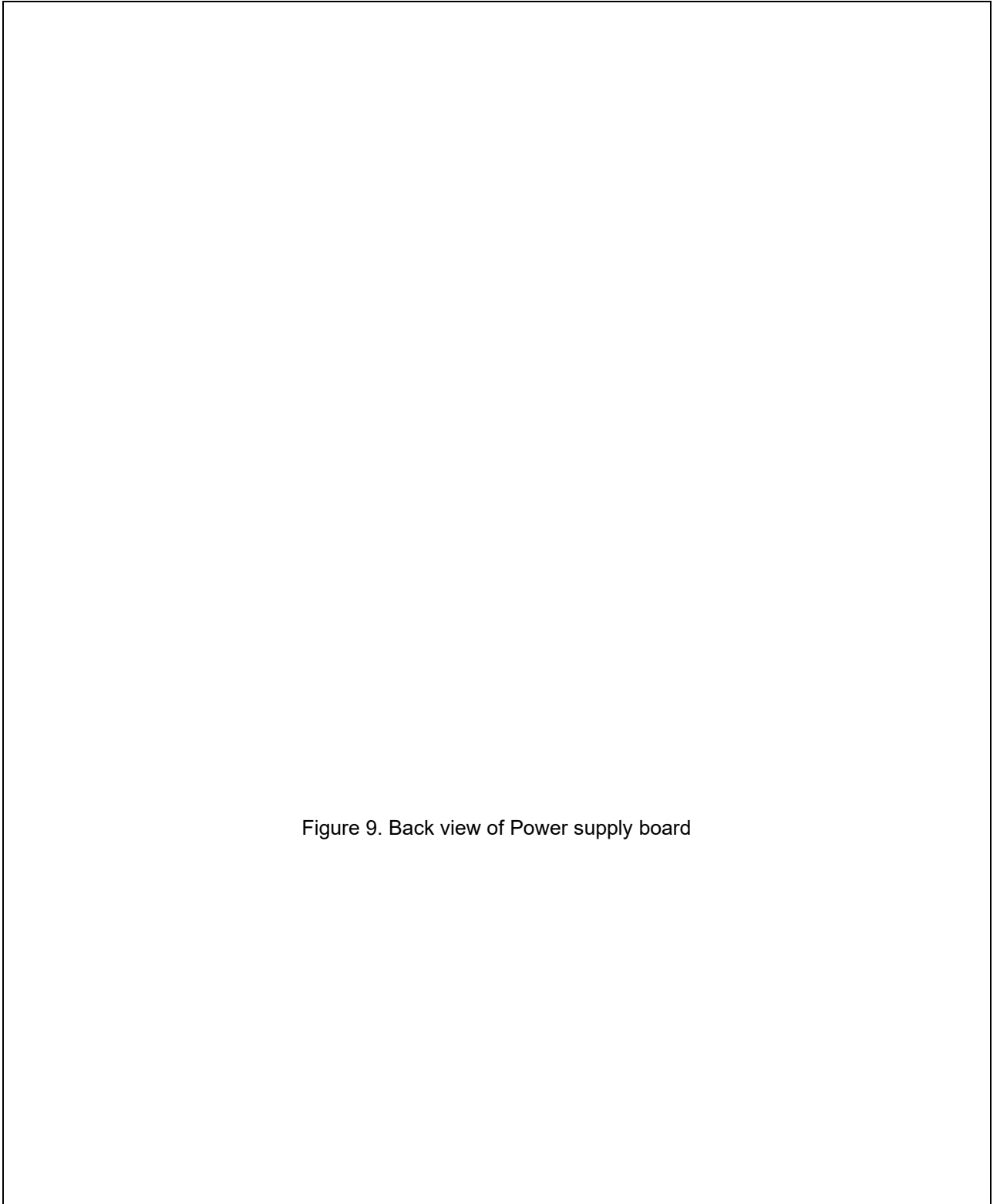

Figure 9. Back view of Power supply board

---END---