

IDC180E

Fast DC charger for electric vehicles



RELIABLE AND SAFE

- IP65 protection and C5 anti-corrosion
- Product design lifecycle over 10 years
- Innovative design with no additional filter mat for maintenance free operation



EFFICIENT AND SMART

- Max. efficiency up to 96.5%
- Dynamic load management to optimize EV charging
- Independent air duct design to achieve efficient cooling



USER FRIENDLY

- Supports multiple authentication and payment options *
- 10-inch touch screen displays more information to start charging effortlessly
- Charging cable management system for premium user experience



FLEXIBLE APPLICATION

- Adaptive voltage range 200-920Vdc, compatible with new electric vehicles
- Plug & charge, easy to commission and use
- Compatibility with PV-ESS system reserved

CIRCUIT DIAGRAM

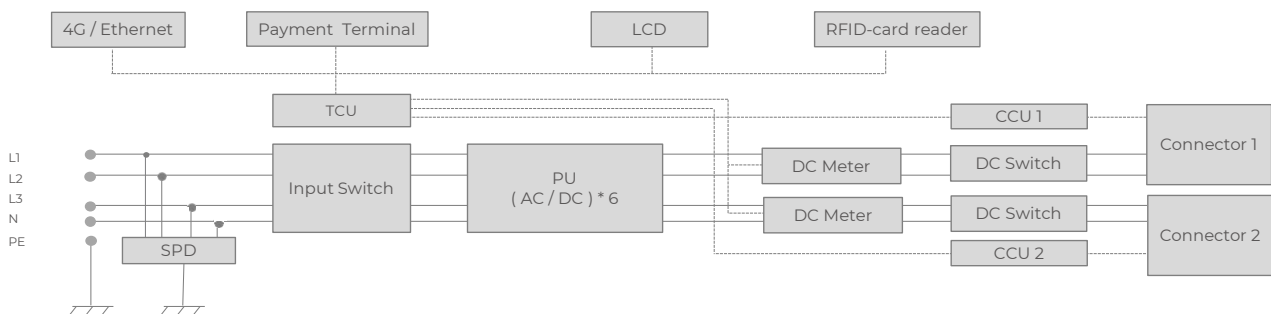

Technical Data	IDC180E
Charging connector	
Connector type	Outlet #1: CCS2 Outlet #2: CCS2
Number of EV served	2
Cable length	5 m 7 m (optional)
Cable management system	Yes
EVSE-vehicle protocol	DIN SPEC 70121 ISO 15118
DC output	
DC output power	Max. 180 kW * 1 or 90 kW * 2
DC output voltage	200 Vdc - 920 Vdc
DC output current	Outlet #1: CCS2 250 A or 380 A (optional) Outlet #2: CCS2 250 A or 380 A (optional)
AC input	
Grid voltage	3 / N / PE, 380 Vac / 400 Vac (± 10 %)
Nominal grid frequency	50 Hz / 60 Hz
Earthing system	TN-C / TN-S / TN-C-S / TT
Rated input current	289 A
Power factor	≥ 0.99
Total harmonic distortion (THDi)	< 5 % at full output power
Oversvoltage category	III
Standby self-consumption	≤ 48W
Efficiency	
Max. efficiency	96.50%
Protection	
Overload protection	Yes
Over/under voltage protection	Yes
Over-current protection	Yes
Short-circuit protection	Yes
Leakage current protection	Yes
Over-temperature protection	Yes
Surge protection	Yes
Emergency stop	Yes
User interface	
Display	10-inch color touch screen
Language	English (standard) Other languages available by firmware upgrade
Authentication	RFID-card / Plug & play / Auto-charge (standard) Plug & charge / Debit or credit-card (optional)
Firmware update	OTA (over-the-air) by iEnergyCharge
RFID system	ISO / IEC 14443 A / B ISO / IEC 15693
Energy metering	MID-certified meter integrated Eichrecht / PTB-certified meter integrated (optional)
Communication interface	WLAN / Ethernet / 4G
Communication protocol (charger-to-CSMS)	OCPP 1.6J Ready for OCPP 2.0.1
Mechanical data	
Dimensions (W*H*D)	930 mm * 1930 mm * 615 mm
Weight	≤ 500 kg
Installation method	Floor mounted
AC cable specification	Min. 150 mm ² Max. 240 mm ²
Environmental data	
Enclosure rating	IP65
Anti-corrosion degree	C5
Mechanical impact protection	IK10 **
Operating ambient temperature range	-35 °C to 55 °C
Allowable relative humidity range	5 % - 95 % (non-condensing)
Max. operating altitude	≤ 2000 m
Cooling method	Smart forced air cooling
Noise (typical)	≤ 65 dB (A) at 1 m distance / 25 °C, at full output power
General data	
Compliance	ETSI / EN 300 328, EN 300 330, EN 301 489-1 / 3 / 17 / 52, ETSI / EN 301 908-1 / 13, EN 50665, BS / EN IEC 61851-1, BS / EN IEC 61851-21-2, BS / IEC EN 61851-23 / 24, EN IEC 62311
Warranty	3 years (standard)

* Authentication via debit or credit card is optional and requires payment terminal integrated in IDC180E. Please consult Sungrow for more information.

** The mechanical impact protection degree of HMI is IK08.