



## Three-phase HiOne Series

# USER MANUAL

---

HiOne-(8-20)T-G3  
HiOne-8B-G3

## Legal Notice

Hoymiles has made every effort to ensure the accuracy and completeness of this manual. However, this manual may be changed and revised due to product enhancements or user feedback.

Hoymiles reserves the right to modify this manual without prior notice at any given time. The latest version of this manual can be found by visiting the Hoymiles official website [www.hoymiles.com](http://www.hoymiles.com) or scanning the QR Code below.



## Warranty

Follow the installation instructions in this manual to ensure warranty compliance and reliability. The current warranty conditions can be accessed at [www.hoymiles.com](http://www.hoymiles.com).

## Contact Information

If you have technical queries or any questions concerning our products, please contact our support through the Hoymiles service portal:



### Germany

[service.de@hoymiles.com](mailto:service.de@hoymiles.com)

### Italy

[service.it@hoymiles.com](mailto:service.it@hoymiles.com)

### Poland

[service.pl@hoymiles.com](mailto:service.pl@hoymiles.com)

### Other EU countries

[service.eu@hoymiles.com](mailto:service.eu@hoymiles.com)

### Spain

[service.es@hoymiles.com](mailto:service.es@hoymiles.com)

### Netherlands

[service.nl@hoymiles.com](mailto:service.nl@hoymiles.com)

### Finland

[service.fi@hoymiles.com](mailto:service.fi@hoymiles.com)

### Australia & New Zealand

[service.au@hoymiles.com](mailto:service.au@hoymiles.com)

### France

[service.fr@hoymiles.com](mailto:service.fr@hoymiles.com)

### Norway

[service.no@hoymiles.com](mailto:service.no@hoymiles.com)

### Austria

[service.at@hoymiles.com](mailto:service.at@hoymiles.com)

### Asia & Pacific

[service.asia@hoymiles.com](mailto:service.asia@hoymiles.com)



### Germany

+49 6994322186

### Poland

+48 918821656

### France

+33 159131589

### Netherlands

+31 852736388



[hoymiles.com](http://hoymiles.com)

## Revision History

Version	Date	Description
REV1.1	20251118	Official Release
REV1.2	20260104	<ul style="list-style-type: none"><li>The packing list has been updated. See <a href="#">6.1 Upacking</a>.</li><li>Mechanical installation steps have been added, including instructions for using the positioning board to drill mounting holes. An additional mechanical installation method (wall-mounted installation) has also been added. See <a href="#">7 Installation Steps</a>.</li><li>The recommended cable size has been updated. See <a href="#">8 Electrical Connection</a>.</li><li>Instructions for creating a new power plant have been added. See <a href="#">10.2 Create a Plant</a>.</li></ul>

# Contents

<b>1</b>	<b>About This Manual</b>	<b>1</b>
1.1	Purpose	1
1.2	Audience	1
1.3	Validity	1
<b>2</b>	<b>Safety Information</b>	<b>2</b>
2.1	Safety Symbols	2
2.2	Additional Symbols	2
2.3	Safety Instructions	3
2.4	EU Declaration of Conformity	4
<b>3</b>	<b>Transportation and Storage</b>	<b>5</b>
3.1	Transportation Requirements	5
3.2	Storage Requirements	5
<b>4</b>	<b>Product Introduction</b>	<b>6</b>
4.1	Product Appearance	6
4.2	LED Indicators	7
4.3	Supported Power Grid	8
4.4	Working Modes	8
4.4.1	Self-consumption Mode	8
4.4.2	Economy Mode	9
4.4.3	Backup Mode	10
4.4.4	Peak Shaving Mode	11
4.4.5	Time of Use Mode	12
4.4.6	Off-grid Mode	12
<b>5</b>	<b>System Overview</b>	<b>13</b>
5.1	Basic System	13
5.2	Whole Home Backup System	14
<b>6</b>	<b>Pre-installation</b>	<b>15</b>
6.1	Unpacking	15
6.2	Environmental Requirements	16
6.3	Space Requirements	17
6.4	Stackable Requirements	17
6.5	Installation Tools	18
<b>7</b>	<b>Installation Steps</b>	<b>19</b>
7.1	Floor-standing Installation	19
7.2	Wall-mounting Installation	23
<b>8</b>	<b>Electrical Connection</b>	<b>26</b>
8.1	Wiring Diagram	26
8.2	Recommended Cable List	27
8.3	Internal overview	28
8.4	Ground Cable Connection	28
8.5	AC Cable Connection	29

8.6	PV Cable Connection.....	31
8.7	(Optional) Battery Cable Connection.....	32
8.8	Communication Cable Connection (COM1).....	34
8.8.1	Smart Meter and CT Connection .....	36
8.8.2	DRM Connection.....	37
8.9	Communication Cable Connection (COM2).....	39
8.10	Installing the Wiring Box Cover.....	40
8.11	Installing the Data Transfer Stick (DTS) .....	41
8.11.1	DTS-WL-G3 (Wi-Fi Mode).....	41
8.11.2	DTS-WL-G3 (LAN Mode).....	41
<b>9</b>	<b>System Commissioning.....</b>	<b>42</b>
9.1	Preparation .....	42
9.2	System Power-on.....	42
<b>10</b>	<b>S-Miles Cloud.....</b>	<b>43</b>
10.1	Start Commissioning.....	43
10.2	Create a Plant.....	49
10.3	Perform System Settings.....	51
10.3.1	Set Advanced Parameters .....	51
10.3.2	Enable DRM Function.....	54
10.3.3	Set Export Management Parameters.....	54
10.3.4	Set Working Mode.....	56
10.3.5	Set Dry Contact Function.....	57
10.4	Upgrade the Firmware.....	60
<b>11</b>	<b>System Maintenance .....</b>	<b>61</b>
11.1	System Power-off.....	61
11.2	Routine Maintenance .....	61
11.3	Troubleshooting .....	62
<b>12</b>	<b>Decommissioning .....</b>	<b>65</b>
12.1	Removing the Product .....	65
12.2	Packing the Product .....	65
12.3	Disposing of the Product .....	65
<b>13</b>	<b>Technical Datasheet.....</b>	<b>66</b>
13.1	HiOne-(8-20)T-G3.....	66
13.2	HiOne-8B-G3.....	67

# 1 About This Manual

## 1.1 Purpose

This manual provides information on the installation, electrical connections, operation, and maintenance of the HiOne series.

Please consider the following before installation:

- Carefully read this manual before operation.
- Keep this manual for reference.

## 1.2 Audience

This manual is intended for use by qualified persons only. Qualified persons must have the following skills:

- Knowledge of how an inverter works.
- Knowledge of how a battery works.
- Training in how to deal with the dangers and risks associated with the installation, maintenance, and use of electrical devices.
- Training in the installation, commissioning, and maintenance of electrical devices.
- Knowledge of and compliance with all applicable laws, standards, and directives.

## 1.3 Validity

This manual is valid for:

- HiOne-(8-20)T-G3
- HiOne-8B-G3

**NOTE**

Model identifier:



**NOTE**

Model identifier:

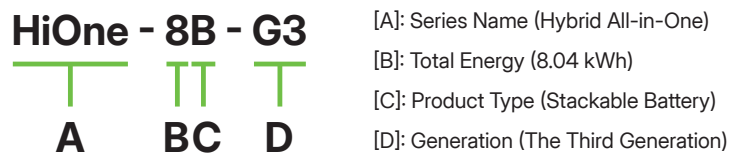





## 2 Safety Information

Before installing, operating, commissioning, and maintaining the product, please carefully read the safety rules and usage instructions in this document as failure to do so may result in safety hazards or device damage. Safety instructions in this manual cannot cover all precautions that should be taken. Please consider the actual conditions on site when performing operations. Any damage caused by a violation of the safety instructions in this manual shall not be the responsibility of Hoymiles.



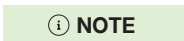

### 2.1 Safety Symbols



Safety symbols are used in this manual as follows:

Symbol	Description
 <b>DANGER</b>	This symbol indicates potential risks that, if not avoided, may lead to death or serious physical injury.
 <b>WARNING</b>	This symbol indicates potential risks that, if not avoided, may lead to personal injury or device damage.
 <b>CAUTION</b>	This symbol indicates potential risks that, if not avoided, may lead to device malfunctions or financial losses.
 <b>NOTICE</b>	This symbol indicates potential risks that, if not avoided, may lead to minor injury or damage to the equipment.
 <b>NOTE</b>	This symbol indicates an important step or tip that leads to the best results but is not safety- or damage-related.

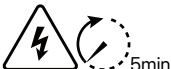
### 2.2 Additional Symbols

The product label contains the following symbols with their meanings described below:

Symbol	Usage
	<b>Caution</b> Failure to observe any warnings contained in this manual may result in injury.
	<b>Danger to life due to high voltages</b> Only qualified personnel can open and maintain the equipment.
	<b>Hot surface</b> Burn danger due to hot surface that may exceed 60°C.
	After the equipment is turned off, wait for at least 5 minutes before opening the equipment or touching live parts.
	<b>Treatment</b> Electrical equipment that has reached the end of life must be collected separately and returned to an approved recycling facility to comply with the European Directive 2002/96/EC on Waste Electrical and Electronic Equipment and its implementation as national law. Return any devices you no longer need to an authorized dealer or an approved collection and recycling facility.

	<p><b>CE mark</b> The product complies with the requirements of the applicable EU directives.</p>
	<p><b>RoHS mark</b></p>
	<p><b>Observe the documentation</b> Read and understand all documentation supplied with the product.</p>

## 2.3 Safety Instructions

To prevent personal injury and property damage and to ensure the long-term operation of the product, read this section carefully and observe all safety information at all times. Failure to observe the prescribed instructions may potentially void the manufacturer's warranty. If in doubt, please contact Hoymiles.

### DANGER

#### **Danger to life from electric shock**

- Only qualified personnel are allowed to install, maintain, or replace the device.
- Qualified personnel must wear personal protective equipment (PPE) during operation.
- Attempting to service the device yourself may result in a risk of electric shock or fire and will void your warranty.
- Never insert or remove the AC connections when the device is running.
- The installation location must be inaccessible to children.
- The device should be installed away from heating devices.
- Before installation, operation, and maintenance, ensure that the upstream and downstream switches are disconnected.
- Before performing any work on the device, disconnect all power supply and wait for at least 5 minutes. The hazardous voltage will exist for up to 5 minutes after disconnection from the power supply.

### WARNING

#### **Risk of burns from hot surfaces**

- The surface of the device might exceed 60°C, and touching the surface may result in burns.
- Do not touch hot surfaces before it cools down.
- All powers should be disconnected from the device before attempting any maintenance, cleaning, or working on any circuits connected to the device.
- Keep away from flammable and explosive materials to avoid fire hazard.
- The device should be installed away from humid or corrosive substances.
- When accessing the internal circuit of the device, wait for at least 10 minutes after disconnecting the power.

### CAUTION

- Ensure that the existing wiring is in good condition and no wire is undersized.
- Do not disassemble any parts of the device which are not mentioned in the installation.
- Authorized service personnel must use insulated tools when installing or working with this device.

**NOTICE**

- The minimum rated temperature of the wire used is 90°C (194°F).
- All electrical connections must be in accordance with local and national standards.
- Only with permission of the local utility grid company, the device can be connected to the utility grid.
- Do not open the inverter device or change any components without authorization, otherwise the warranty commitment for the device will be invalid.
- Prior to the application, please read this section carefully to ensure the correct and safe application. Please keep the user manual properly.
- The manual contains no instructions for user-serviceable parts. See Warranty for instructions on obtaining service.
- If an error occurs, contact your local distributor or qualified electricians.

## 2.4 EU Declaration of Conformity

Hoymiles Power Electronics Inc. hereby declares that the inverter described in this document is in compliance with the basic requirements and other relevant provisions of the following directives.

- Electromagnetic Compatibility Directive 2014/30/EU (EMC)
- Low Voltage Directive 2014/35/EU (LVD)
- Restriction of the use of certain hazardous substances Directive 2011/65/EU and its amendment directives (EU) 2015/863 (RoHS)
- Waste Electrical and Electronic Equipment Directive 2012/19/EU (WEEE)

Hoymiles Power Electronics Inc. hereby declares that the battery described in this document is in compliance with the basic requirements and other relevant provisions of the following directives.

- Electromagnetic Compatibility Directive 2014/30/EU (EMC)
- Restriction of the use of certain hazardous substances Directive 2011/65/EU and its amendment directives (EU) 2015/863 (RoHS)
- EU Battery Regulation (EU) 2023/1542.

More detailed information can be found at <https://www.hoymiles.com>.

## 3 Transportation and Storage

### 3.1 Transportation Requirements

#### Placement Requirements

- Place the products in the original packaging or specially designed transport packaging. The packaging materials should have sufficient strength and cushioning performance to prevent damage caused by collisions and squeezes during transportation.
- Secure the products firmly inside the packaging to avoid displacement during transportation. For large or heavy products, additional fixing devices may be required.
- Maintain stability and avoid sudden starts, stops, or excessive vibration during transportation.

#### Personnel Requirements

- Observe the safety symbols on the package of the products before transportation.
- Pay attention to the weight of the products. Be cautious to avoid injury when moving. Handle the products according to the personnel quantity required by local regulations.
- Wear protective gloves and use professional handling equipment to prevent injuries.
- Hold the handle to lift the products and keep them horizontal.
- Ensure that only qualified and experienced personnel perform relevant operations.

### 3.2 Storage Requirements

#### Placement Requirements

- Keep the products in their original packaging with desiccants retained until they are ready for installation.
- To avoid personal injury or device damage, stack products carefully to prevent them from falling.
- Do not tilt or invert the package.
- Do not place heavy objects on the products, as this may damage the equipment housing or internal components.

#### Environmental Requirements

- The storage temperature should be between  $-30^{\circ}\text{C}$  and  $65^{\circ}\text{C}$ , and the relative humidity should be between 5% and 95%, without condensing.
- Store the products in a clean and dry place to protect them from dust and moisture.
- Store the products in a well-ventilated place to ensure proper air circulation and prevent equipment overheating.
- Do not store the products in places exposed to direct sunlight, wet by rain, or with strong electric fields.
- Do not store the products in places with chemically corrosive substances or where there are pests and rodents.

#### Routine Maintenance

- The battery SOC should be between 45% and 50%. The battery needs to be recharged every 6 months if it is not used, and it is recommended to store it after it is first charged to 100%, then discharged to 50%, and finally powered off.
- The battery needs to be maintained at a maximum interval of 6 months.
- The requirements for the recharge interval after the battery is fully discharged are as follows.
  - a) If the environmental temperature is between  $45^{\circ}\text{C}$  and  $50^{\circ}\text{C}$ , it should be recharged within 7 days;
  - b) If the environmental temperature is between  $35^{\circ}\text{C}$  and  $45^{\circ}\text{C}$ , it should be recharged within 15 days;
  - c) If the environmental temperature is no more than  $35^{\circ}\text{C}$ , it should be recharged within 30 days.
- When the device is unused, the battery SOC should be between 45% and 55%, and the battery output should be disconnected to prevent the battery from draining.
- During the storage period, the products should be checked regularly, and it is recommended to check the products once every three months. Replace the packing materials damaged by insects or rodents in a timely manner.
- If the products have been stored for three months or longer, they must be fully inspected and tested by authorized personnel before being put into use.

# 4 Product Introduction

The HiOne series is designed for residential and small C&I PV ESS systems. The hybrid inverter, battery, and EMS are integrated into one unit to provide users with a comprehensive PV ESS solution.

## 4.1 Product Appearance

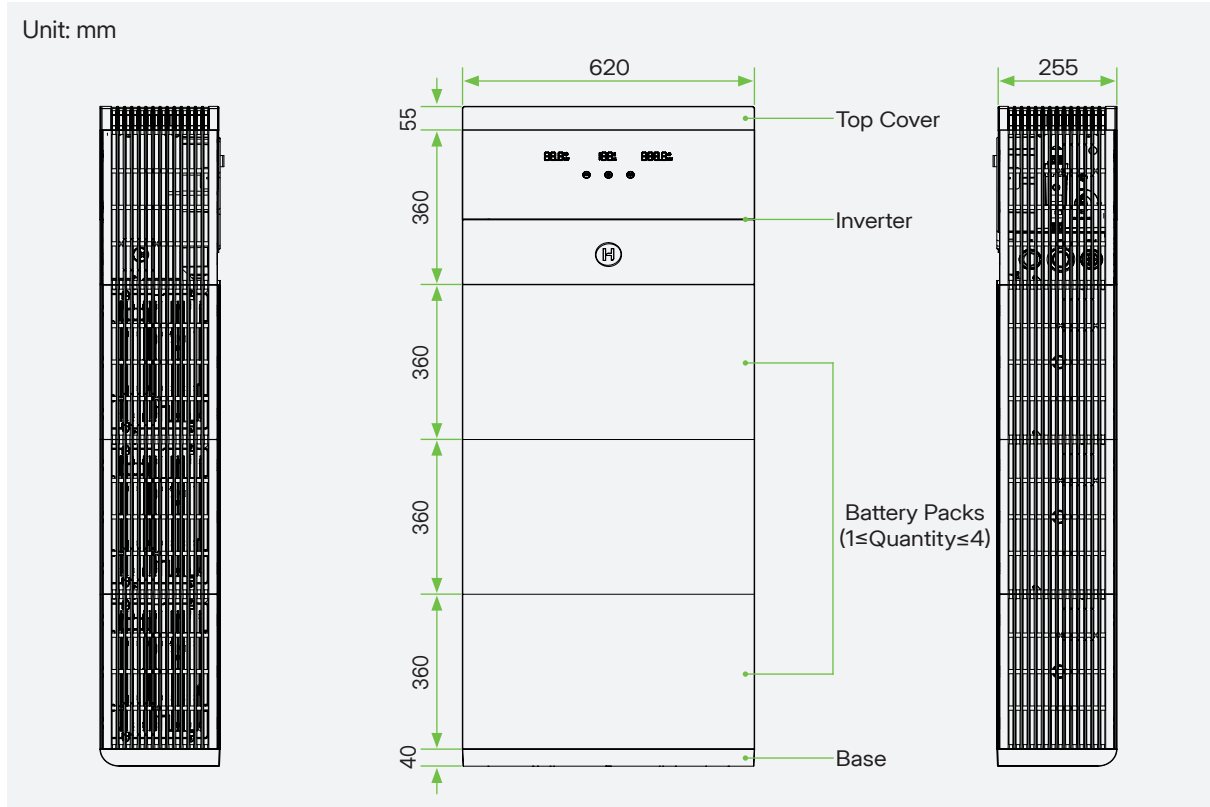

Figure 4-1 Appearance and Dimensions

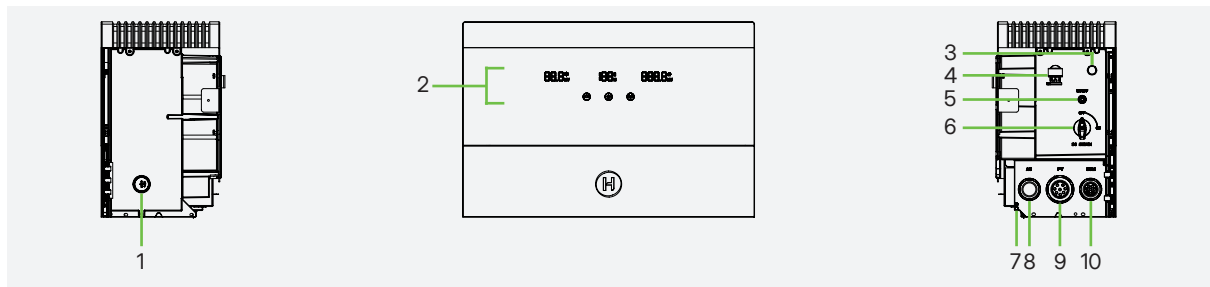

Figure 4-2 Overview

No.	Description	No.	Description
1	Cable Entry for Parallel Batteries	6	DC Switch
2	LED Indicators	7	Ground Terminal
3	Relief Valve	8	AC Cable Entry
4	Data Transfer Stick (DTS) Port	9	PV Cable Entry
5	Power Button	10	Communication Cable Entry

## 4.2 LED Indicators

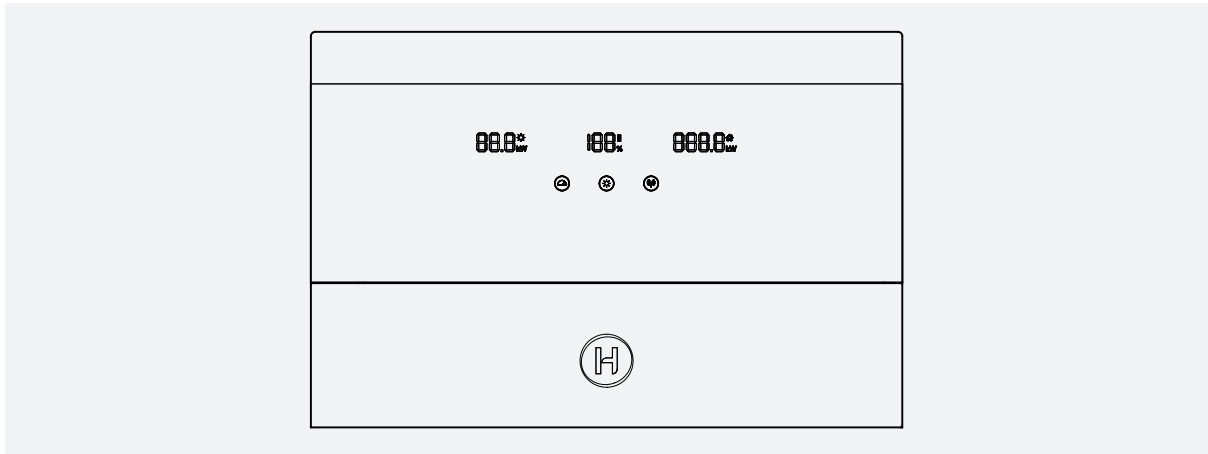

Figure 4-3 LED Indicators

Indicator		Status		Explanation
	PV		Digital readout	Real-time Power Generation
		/	Off	No PV Power
	Battery SOC		Digital readout	Real-time SOC
		/	Off	No Battery Connection
	Battery Status		Solid white	Battery Charging
			Solid red	Battery Fault
		/	Off	Battery Discharging/Standby/No Battery Connection
	Load Consumption		Digital readout	Real-time power consumption
			0.0 display	No load connection/Zero consumption/No meter connection
	Meter		Solid white	Normal
			Solid red	Communication Fault
		/	Off	No Meter Connection
	State		Solid white	System Normal Operation/Standby
			Solid red	System Fault
		/	Off	System Power-off
	Internet		Solid white	Connected to Network and Cloud
			Flashing white	Connected to Network, but Not Connected to Cloud
		/	Off	No DTS Connection

### 4.3 Supported Power Grid

There are different ways of wiring for different grid systems. TN-S / TN-C / TN-C-S / TT are shown as follows.

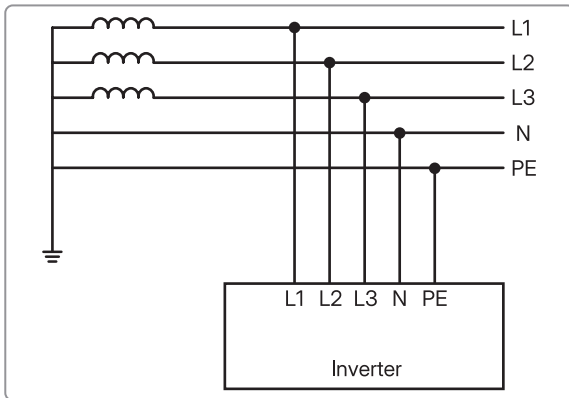

Figure 4-4 TN-S

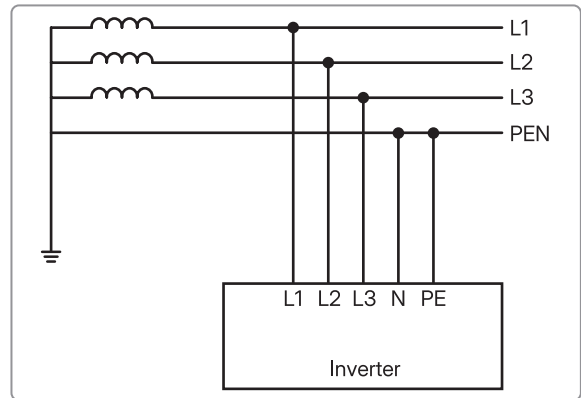

Figure 4-5 TN-C

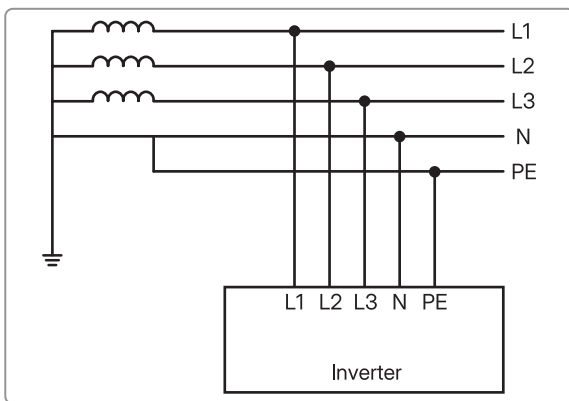

Figure 4-6 TN-C-S

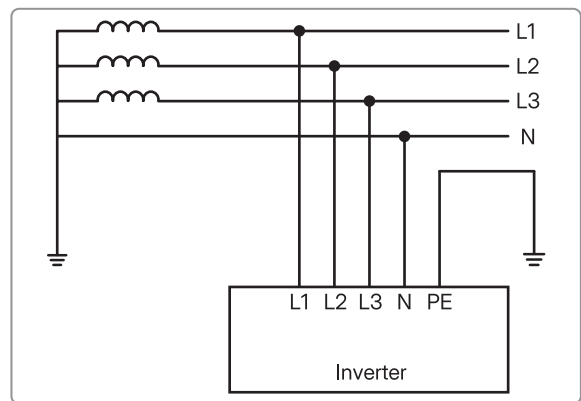

Figure 4-7 TT

### 4.4 Working Modes

The HiOne series has five working modes for you to choose in on-grid status, such as Self-consumption Mode, Economy Mode, Backup Mode, Peak Shaving Mode, and Time of Use Mode. You can choose the working modes according to your lifestyle and environment. When the system is not connected to the grid, you can choose the Off-grid Mode.

#### 4.4.1 Self-consumption Mode

The Self-consumption Mode is the basic working mode, which can reduce the use of grid power.

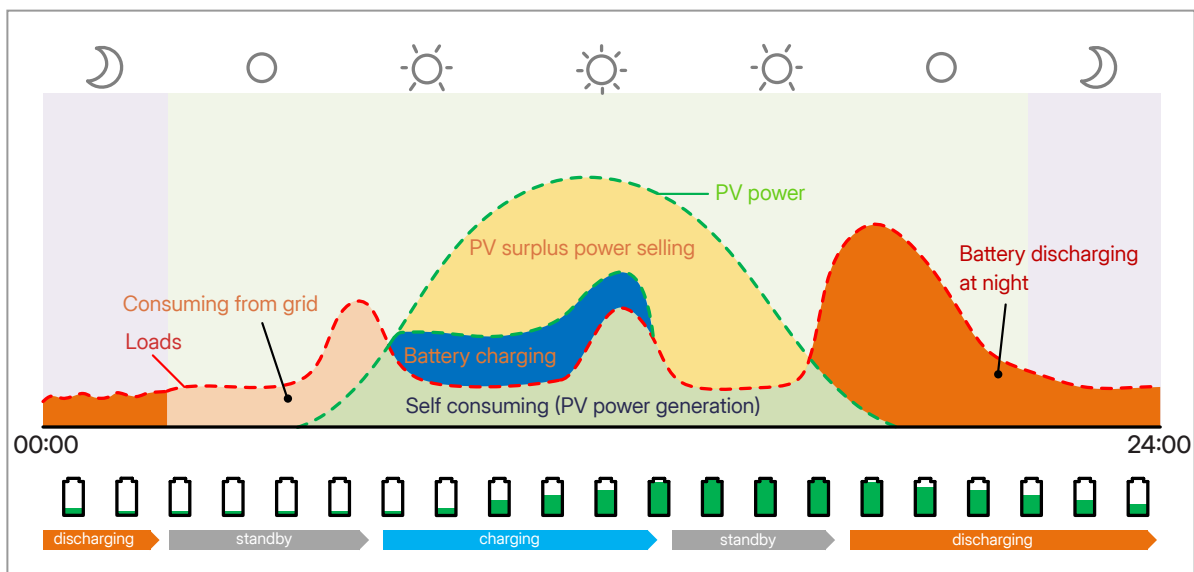

Figure 4-8 Power Flow of Self-consumption Mode

Time Period	Inverter Working Status
PV power is sufficient	$(PV \rightarrow \text{Loads}) > (PV \rightarrow \text{Battery}) > (PV \rightarrow \text{Grid})$ The power generated from PV first supplies the loads, any excess power can charge the battery, and if there is still surplus power, it can be sold to the grid (or limited if necessary).
PV power is insufficient	$PV + \text{Battery} + \text{Grid} \rightarrow \text{Loads}$ The battery discharges power to the loads, and once its capacity reaches its reserved capacity, it automatically stops discharging, and the grid supplies power to the loads.

**NOTE**

- In order to maximize self-consumption, the grid will not charge the battery in this mode, and only the surplus PV power can charge the battery. The grid will initiate the charging process only when the battery SOC falls below the reserved capacity.
- Reserved SOC (10%-100%): The minimum battery SOC that can be reserved due to infrequent power outages. For details, refer to battery specifications.

### 4.4.2 Economy Mode

The Economy Mode can maximize electricity savings by shifting the battery state to avoid using grid electricity at peak hours. In this mode, the battery can be charged or discharged according to valley or peak electricity prices time. The system will calculate the savings based on the set currency.

Time Period	Inverter Working Status
Peak Hour	$(PV + \text{Battery} \rightarrow \text{Loads}) > (PV + \text{Battery} \rightarrow \text{Grid})$ The power generated from PV and battery can simultaneously supply the loads. Any excess power is then sold to the grid (or limited if necessary). The grid power will not be used until there is no PV power or the battery SOC reaches the reserved capacity.
Off-peak Hour	$(PV + \text{Grid}) \rightarrow (\text{Loads} + \text{Battery})$ The power from PV and grid can simultaneously supply the loads and charge the battery.
Partial-peak Hour	Its working logic is the same as <b>"Self-consumption Mode"</b> .

**NOTE**

- Reserved SOC (10%-100%): The minimum battery SOC that can be reserved due to infrequent power outages. For details, refer to battery specifications.
- Time Setting:
  - Period (1-4): Set the start and end dates of the electricity rate period.
  - Time Range (2): Set time period in one week.
  - Peak Hour: Set peak electricity price time and trade price.
  - Off-peak Hour: Set off-peak electricity price time and trade price.
  - Partial-peak Hour: Set partial-peak trade price.

### 4.4.3 Backup Mode

The Backup Mode is suitable for areas with frequent power outages. This mode will maintain the battery capacity at a relatively high level to ensure that the EPS loads can be used when the grid is off.

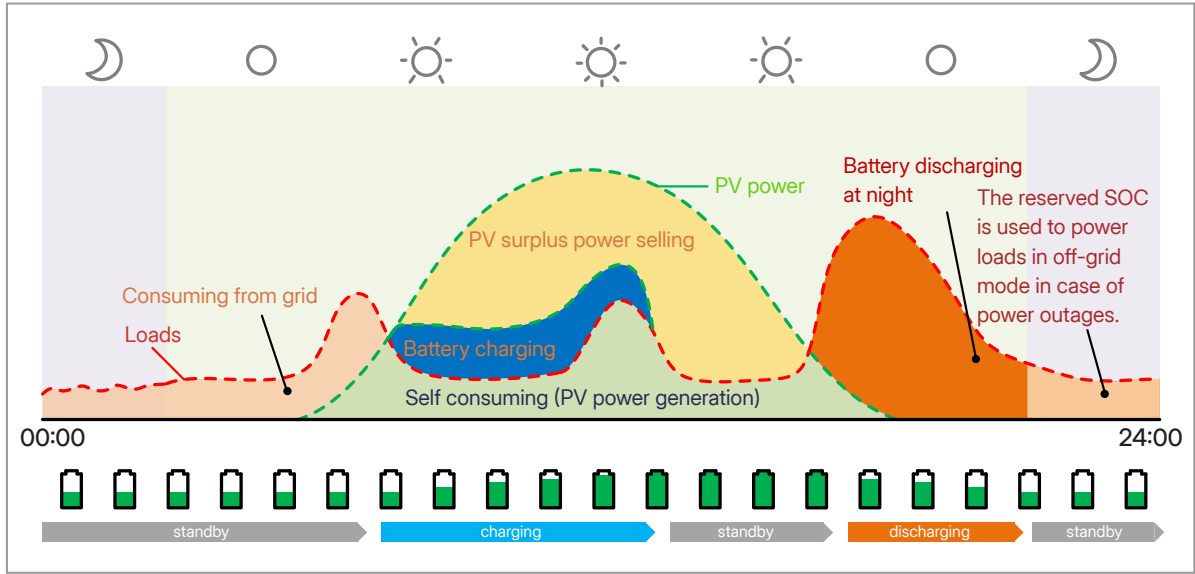

Figure 4-9 Power Flow of Full Backup Mode

Time Period	Inverter Working Status
PV power is sufficient	$(PV \rightarrow \text{Loads}) > (PV \rightarrow \text{Battery}) > (PV \rightarrow \text{Grid})$ The power generated from PV first supplies the loads. Any excess power can charge the battery, and if there is still surplus power, it can be sold to the grid (or limited if necessary).
PV power is insufficient	$\text{Battery SOC} > \text{Reserved Capacity}$ $(PV + \text{Battery}) \rightarrow \text{Loads}$ The battery discharges power to the loads, and when its SOC reaches reserved capacity, it automatically stops discharging.
	$\text{Battery SOC} \leq \text{Reserved Capacity}$ $(PV + \text{Grid}) \rightarrow \text{Loads}$ The grid supplies power to the loads. The battery does not discharge until the grid outage occurs. The battery needs to be recharged to the reserved capacity after the grid is normal.

**NOTE**

Reserved SOC (60%-100%): The minimum battery SOC that can be reserved due to infrequent power outages. For details, refer to battery specifications.

### 4.4.4 Peak Shaving Mode

The Peak Shaving Mode is used to level out peak power in electricity use to maximize electricity savings. In this mode, the Peak Meter Power (the maximum power that the inverter obtains from the grid) can be set; only when PV and battery can fully power the loads, can the Peak Meter Power be limited.

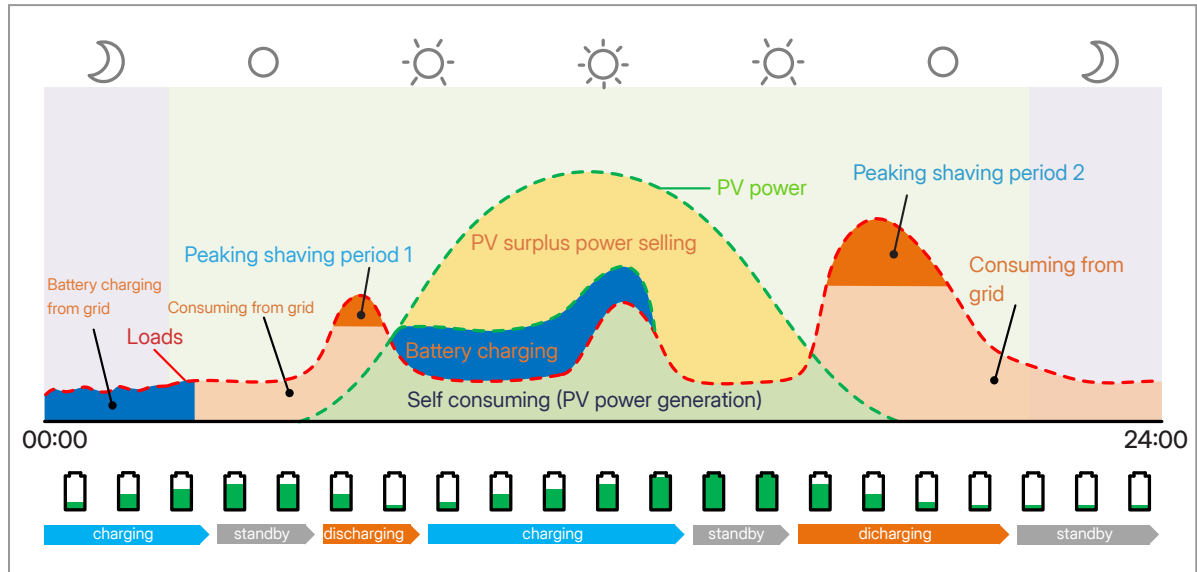

Figure 4-10 Power Flow of Peaking Shaving Mode

Time Period	Inverter Working Status
Grid Consumption Power > Peak Meter Power	PV + Battery → Loads The power generated from PV and battery can simultaneously supply the loads. The grid power will not be used until there is no PV power or the battery SOC reaches the reserved capacity.
Time Period	Inverter Working Status
Grid Consumption Power < Peak Meter Power	Battery SOC > Peak Capacity Its working logic is the same as “ <b>Self-consumption Mode</b> ”.
	Battery SOC ≤ Peak Capacity (PV + Grid → Loads) The grid can supply the loads and charge the battery at a power not higher than the peak meter power.

**NOTE**

- Reserved SOC (10%-100%): The minimum battery SOC that can be reserved due to infrequent power outages. For details, refer to battery specifications.
- Baseline SOC (10%-100%): The minimum battery SOC that can be reserved during peak meter power time.
- Peak meter power (0-60000 W): The maximum load consumption power from the grid side.

## 4.4.5 Time of Use Mode

The Time of Use Mode allows users to customize the charging and discharging time of the battery within eight periods. Users can set the charging and discharging time according to the local peak and valley electricity price to save costs.

Time Period	Inverter Working Status
Charging Period	The battery will be charged from the grid at the pre-set charging power until the battery is charged to the pre-set stop charging SOC (%).
Discharging Period	The battery will discharge power to the loads and the grid at the pre-set discharging power until the battery discharges to the pre-set stop discharging SOC (%).
Other Period	Its working logic is the same as " <b>Self-consumption Mode</b> ".

### NOTE

- Reserved SOC (10%-100%): The minimum battery SOC that can be reserved due to infrequent power outages. For details, refer to battery specifications.
- Time period (1-8):

Charge Time	The battery can be charged at valley electricity price time.
Charge Power (0-100%)	The battery can be charged at this power.
Stop Charge SOC (0-100%)	The battery will stop charging when the battery SOC reaches this value.
Discharge Time	The battery can discharge at peak electricity price time.
Discharge Power (0-100%)	The battery can discharge at this power.
Stop Discharge SOC (0-100%)	The battery will stop discharging when the battery SOC reaches this value.

## 4.4.6 Off-grid Mode

The Off-grid Mode is used when the system is not connected to the grid.

# 5 System Overview

## 5.1 Basic System

The whole system has a rich application scenario, which supports the deep integration of PV, ESS, and EV Charger.

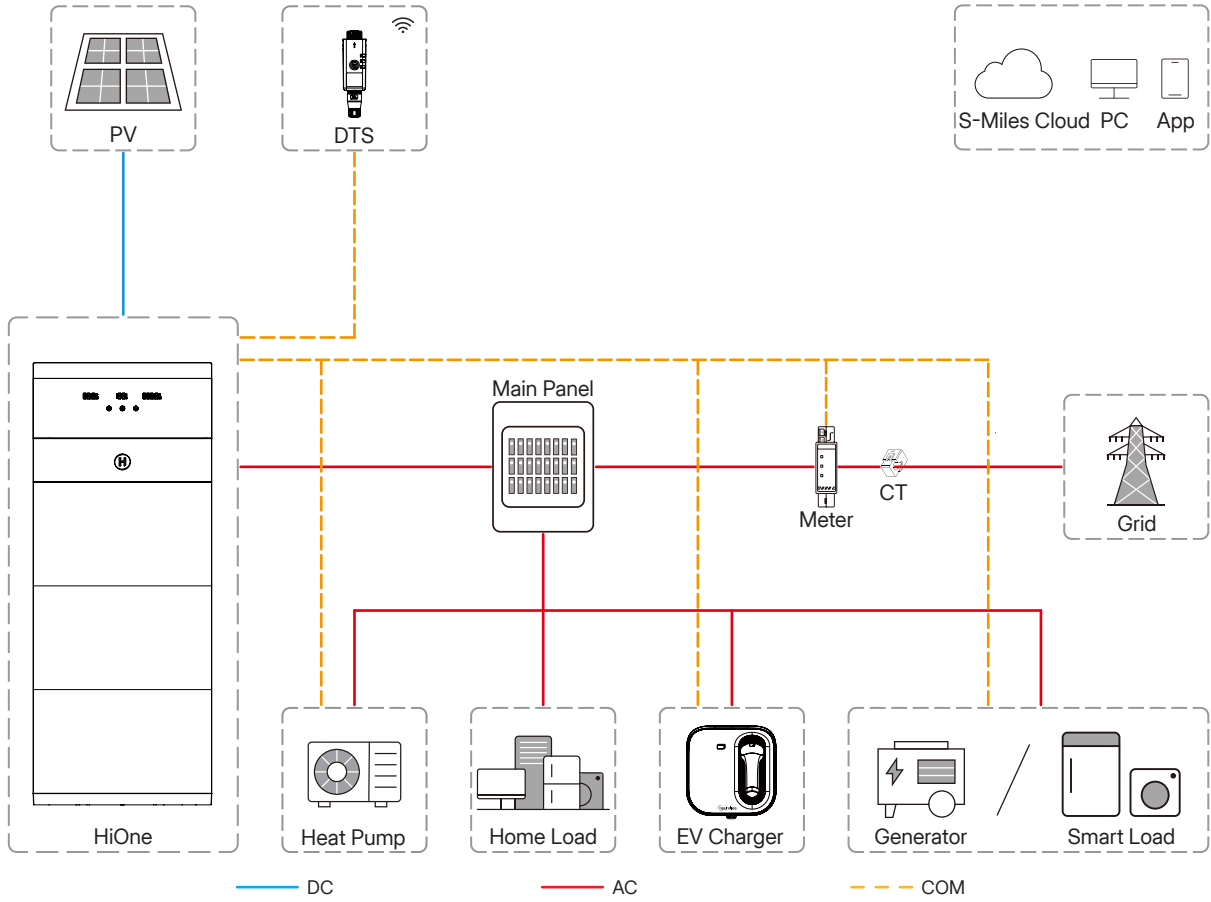

Figure 5-1 Basic System

## 5.2 Whole Home Backup System

In the whole home backup system, the whole home load, smart load, generator, microinverter, and EV charger can be connected to a Hoymiles Gateway. In the event of a grid outage, other components in this energy storage system will power the loads.

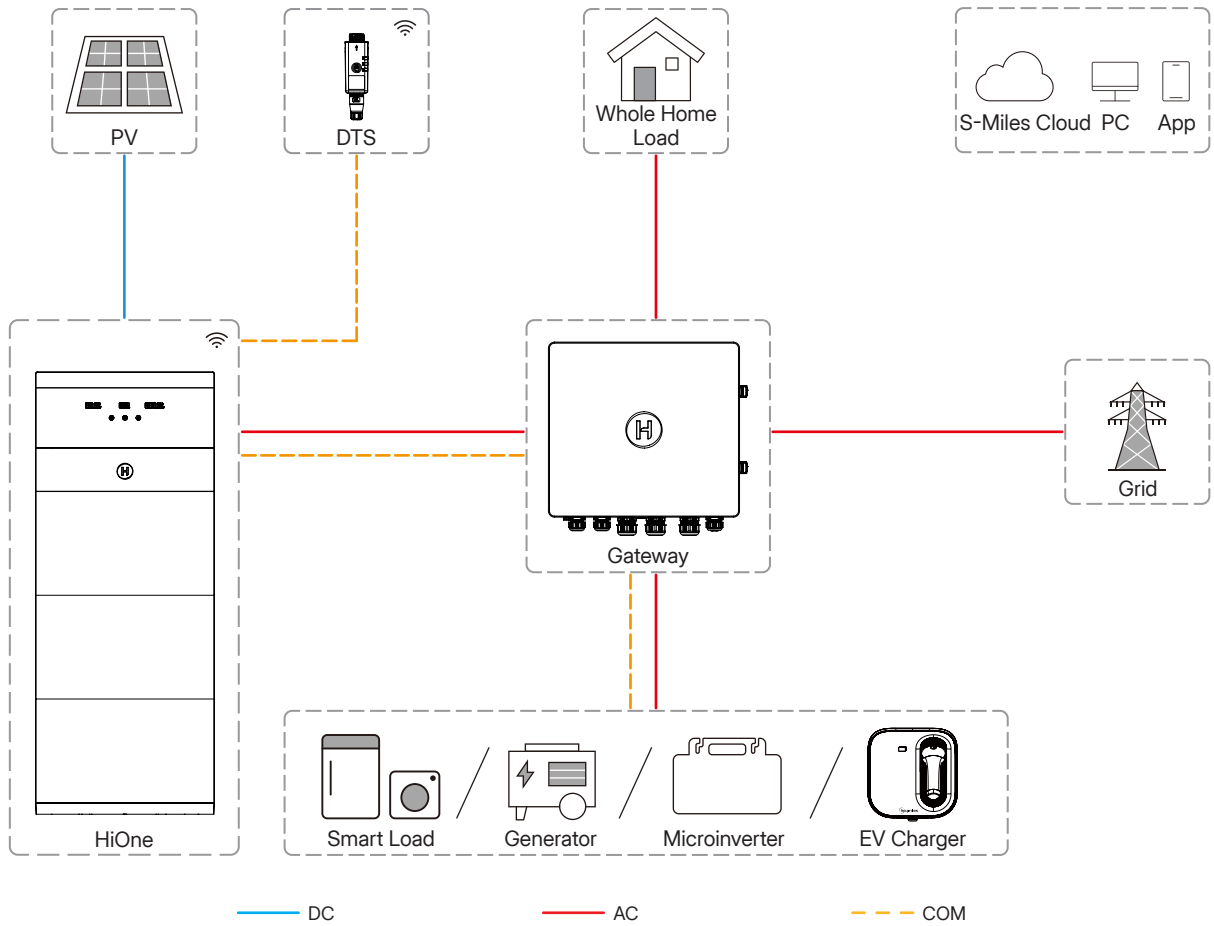

Figure 5-2 Whole Home Backup System

**NOTE**

Up to two HiOne series products can be connected in parallel.

## 6 Pre-installation

**⚠ DANGER**

**Danger to life due to fire or explosion!**

- Despite careful construction, electrical devices can cause fires. This can result in death or serious injury.
- Do not install the product in places containing highly flammable materials or gases.
- Do not install the product in places where there is a risk of explosion.









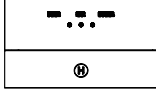

**⚠ WARNING**

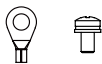
- Make sure there is no electrical connection before installation.
- To avoid electric shock or other injuries, make sure that holes are not drilled over any electrical parts or plumbing installations.
- Qualified personnel must wear personal protective equipment (PPE) during operation.

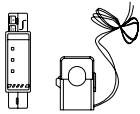

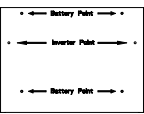

### 6.1 Unpacking

Unpack the package and carefully take out the product and other accessories. Check if the deliverables are complete and intact after unpacking the product. Please contact your supplier if the components are missing or damaged upon receipt of the product.

HiOne-(8-20)T-G3 Packaging Box

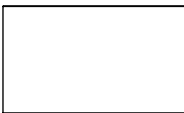
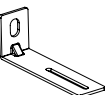
 Inverter*1	 Bracket*2	 Expansion Screw M8*2	 OT Terminal*2 Screw M4*8	 Communication Cable (5 m)*1
 Three-phase Meter*1	 Core*2	 DTS-WL-G3*1	 Decorative Cover*2	 Positioning Board*1
 Document*1				

HiOne-8B-G3 Packaging Box

 Battery*1	 Bracket*2	 Expansion Screw M8*2	 Screw M4*6	 Decorative Cover*2
--	--	--	---	---

Accessory Packaging Box

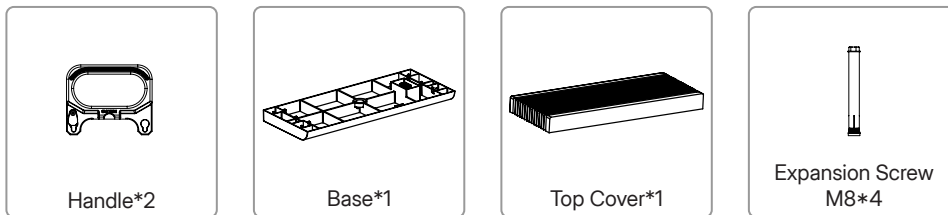

Optional Accessory Packaging Box

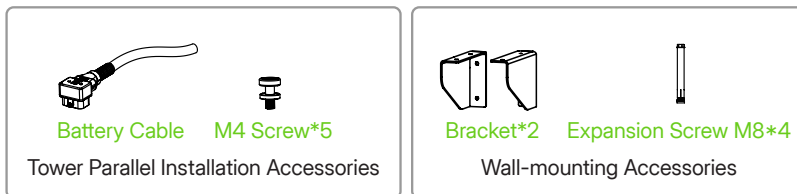

**NOTE**  
 You need to buy accessories separately depending on the installation type. For a tower parallel system, order the Tower Parallel Installation Accessories. For a wall-mounted installation, order the Wall-mounting Accessories.

## 6.2 Environmental Requirements

- The product is designed with a protection degree of IP66 and can be installed indoors or outdoors.
- The product should be installed in a place where it can be protected from direct sunlight or bad weather such as snow, rain, or lightning.
- The ambient temperature should be between -20°C and 55°C. High ambient temperatures (above 45°C) will cause power derating of the inverter.
- The relative humidity should be less than 95%, without condensing.
- The product should be installed on a solid surface that is suitable for its dimensions and weight.
- The product should be installed in an environment with good ventilation and heat dissipation conditions.
- The product should be installed far from noise-sensitive areas.
- The product should be installed far from flammable materials, corrosive chemicals, and heating devices.
- The product should be installed in a place where its enclosure and heat sink are not easy to be touched, because these parts are hot during operation.

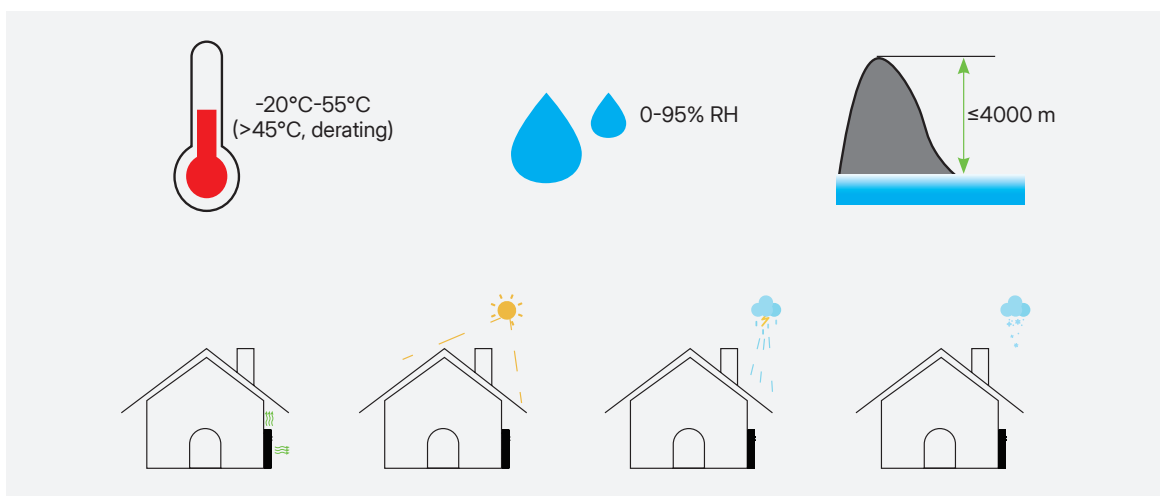

Figure 6-1 Installation Environment

### 6.3 Space Requirements

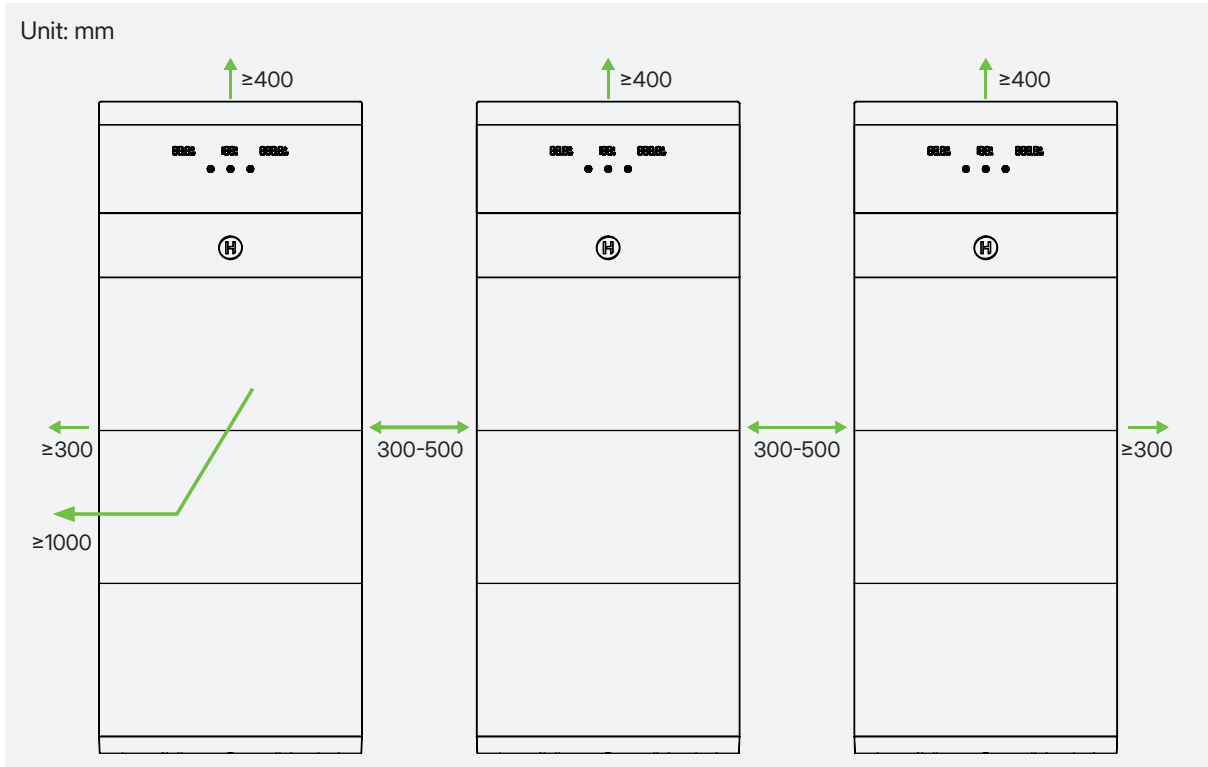
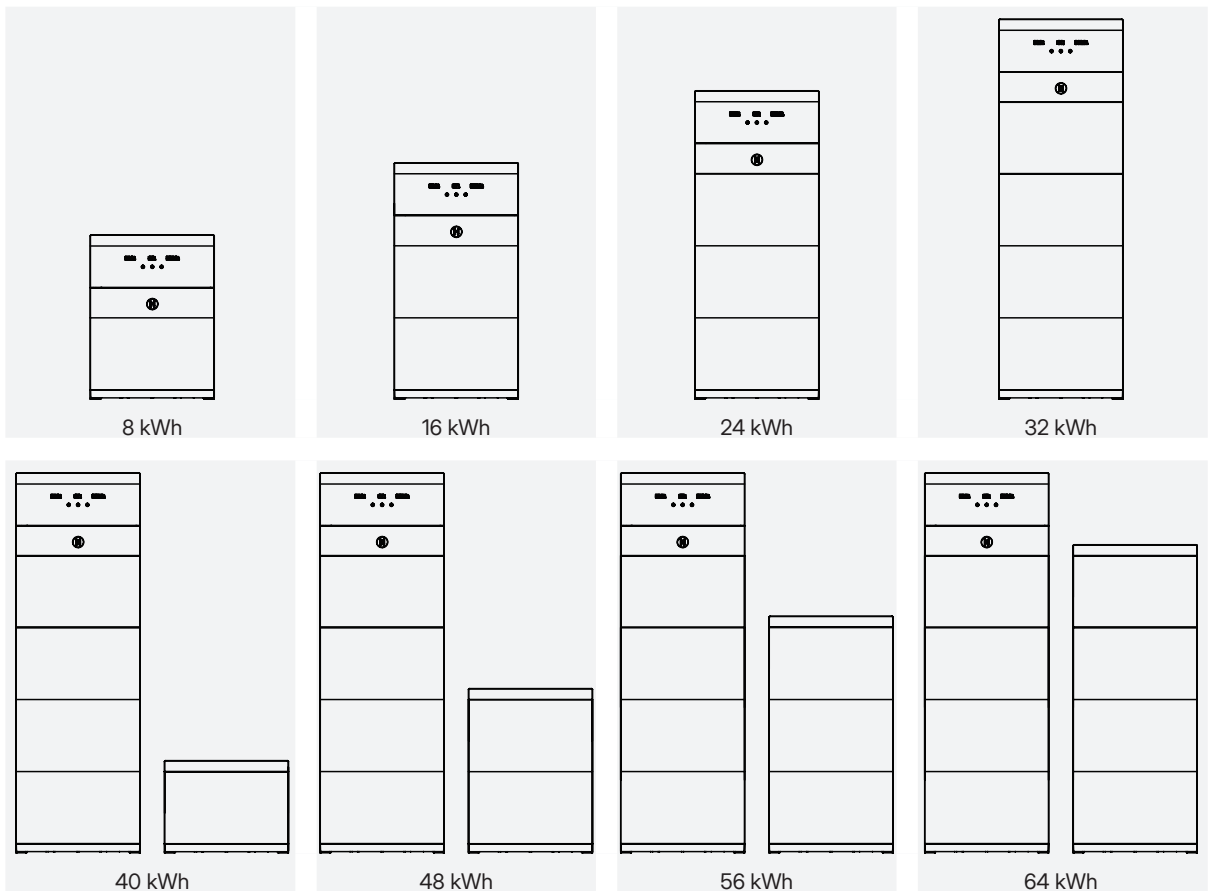
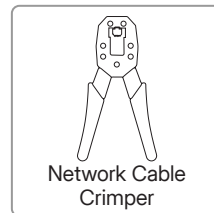
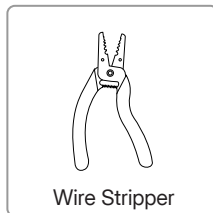
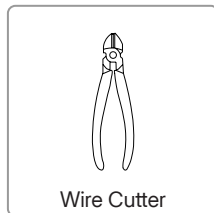
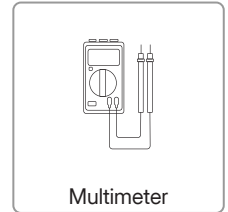
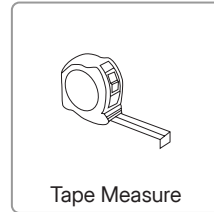
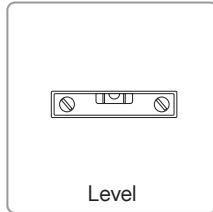
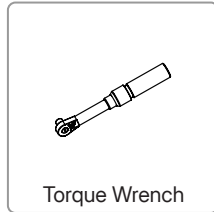
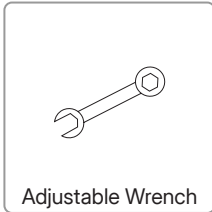
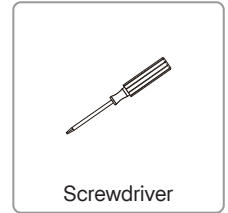
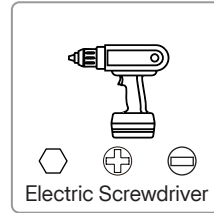
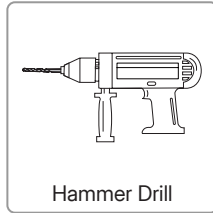
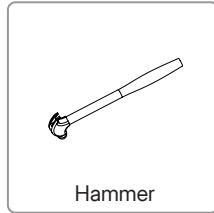
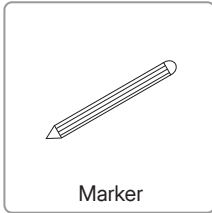

Figure 6-2 Space Requirements

### 6.4 Stackable Requirements



## 6.5 Installation Tools



### Personal Protective Equipment (PPE)



## 7 Installation Steps

### 7.1 Floor-standing Installation

**Step 1** Place the base on a level ground, parallel to the wall, and keep a distance of 30 mm to 35 mm. Ensure that the level bubble is in the center; if not, use a flat head screwdriver to adjust the base.

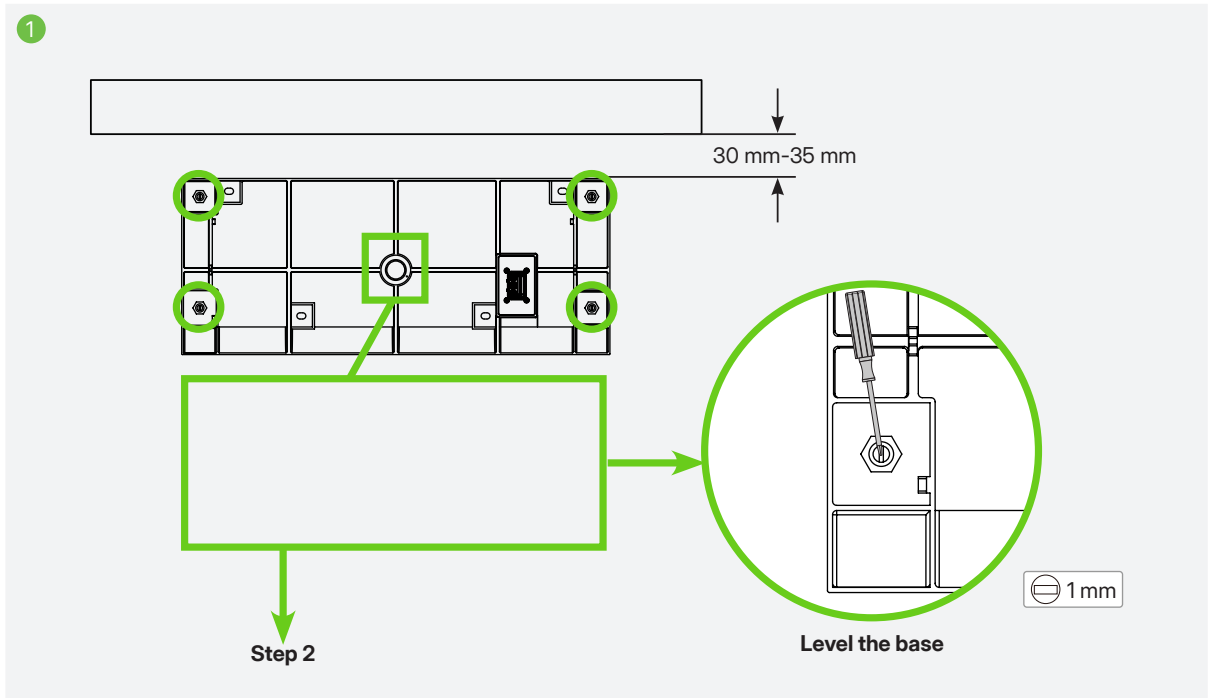

**Step 2** Fix the base.

- A. Mark hole positions.
- B. Drill holes.
- C. Hammer and tighten the expansion screws.
- D. Unscrew the screws while leaving sleeves in place.
- E. Place the base, insert the screws into the sleeves, and tighten them.

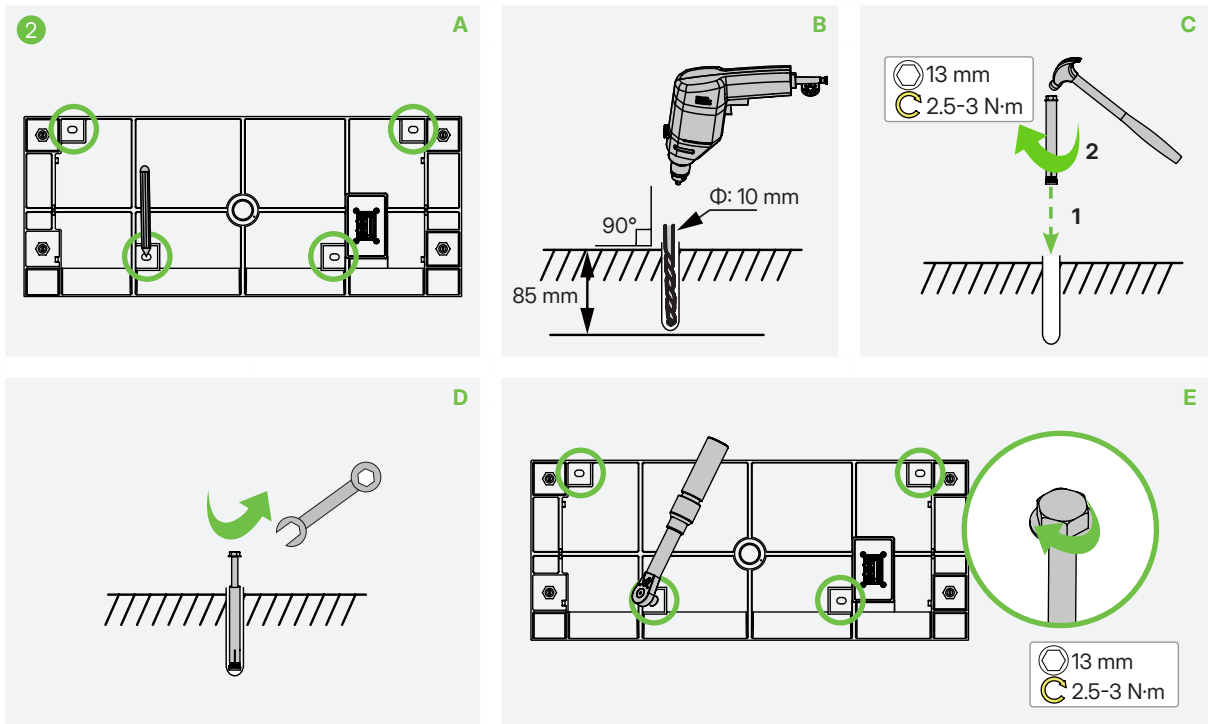

**Step 3** Use the Positioning Board to mark the drilling positions.

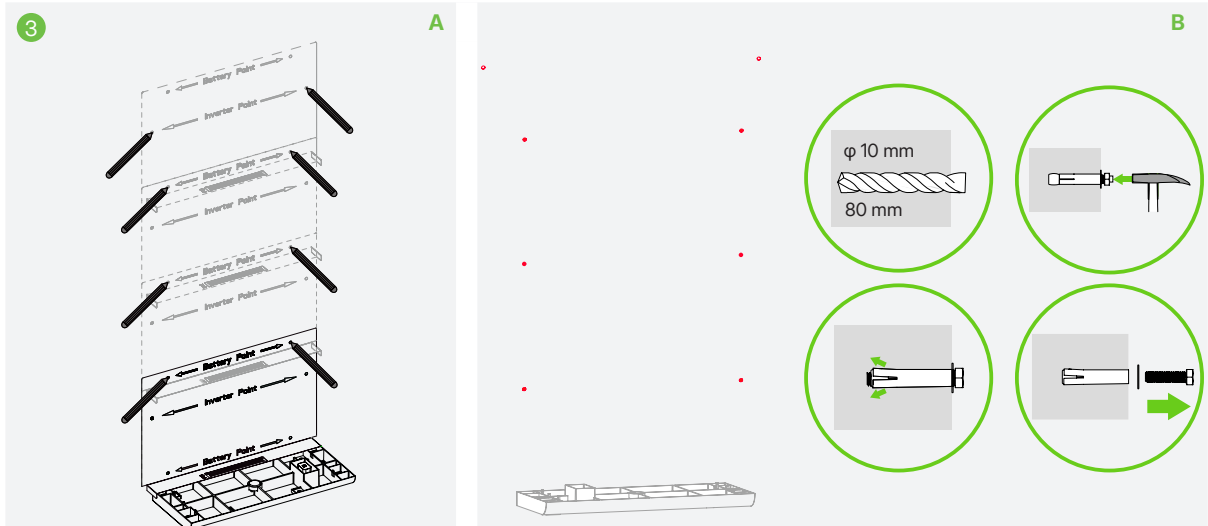

**Tips: How to Use the Positioning Board?**

The positioning board has a specific section that is designed to be bent. You need to bend that section first. After bending it, you clip the Positioning Board to the base.

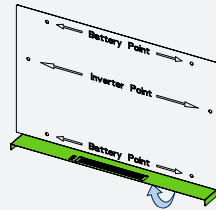

**Step 4** Install the handles.

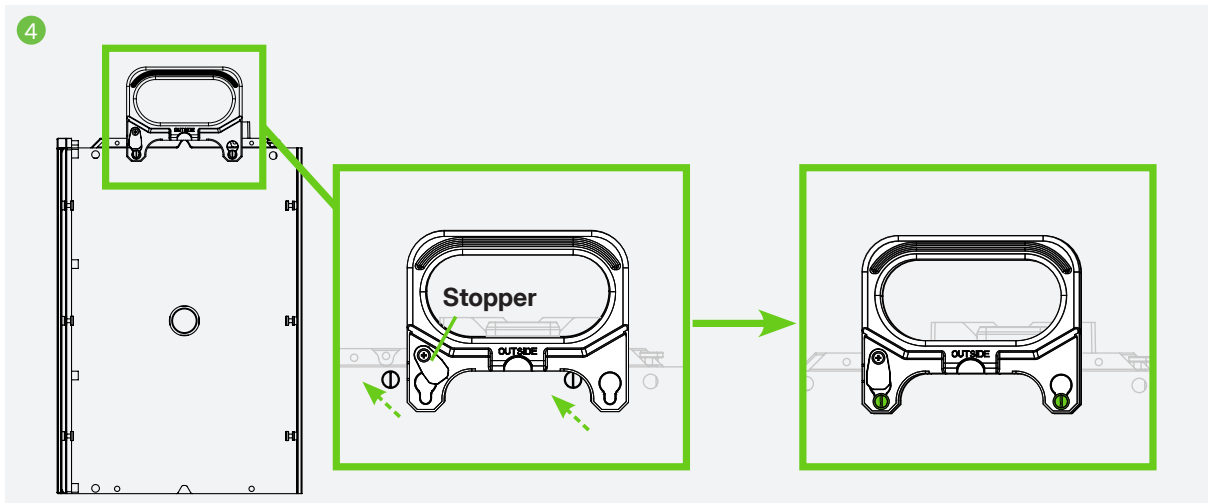

**Step 5** Hold the handles to lift the battery, align the connector, and place the battery on the base.

**Step 6** Remove the connector cover of the battery.

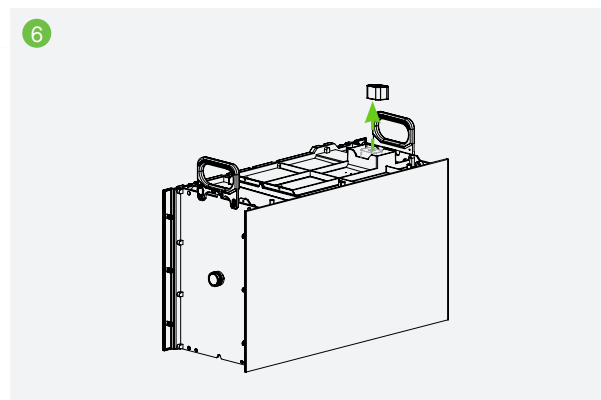
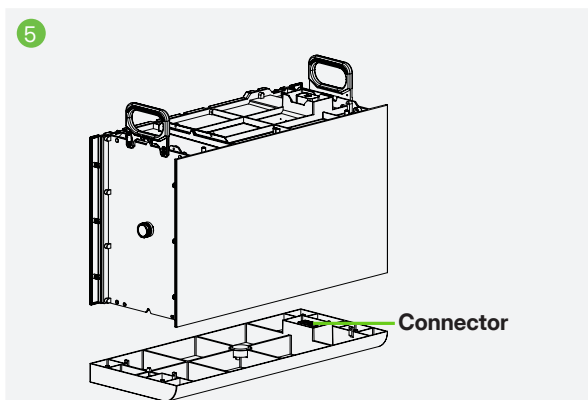

**Step 7** Fix the battery.

- A. Use M4 screws secure the connection between the base and the battery.
- B. Place the two L-shaped brackets on the battery and use M4 screws to fix them on the battery.
- C. Secure the battery to the wall using L-shape brackets and M8 expansion screws.

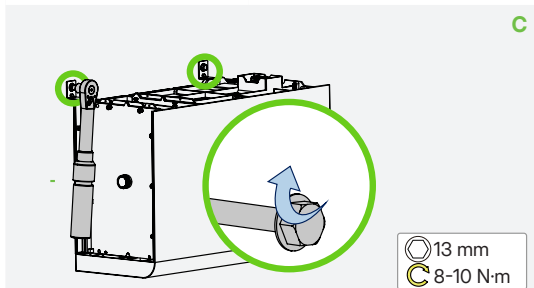
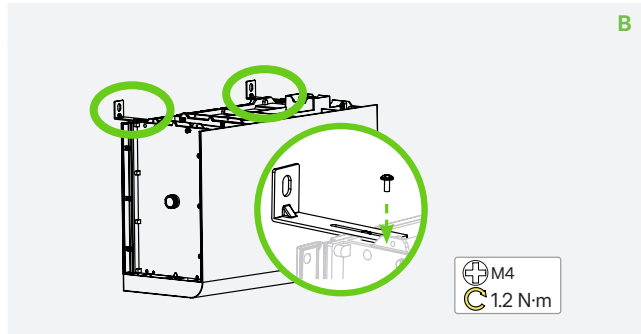
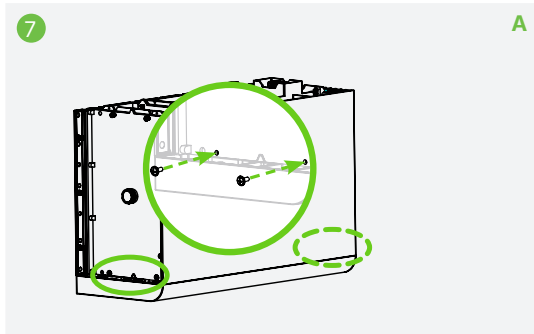

**Step 8** Hold the handles to lift and stack the battery packs based on actual installation. Repeat **step 5** to secure the connection between the battery packs and fix the battery on the wall.

**Step 9** Use the handles provided to place the inverter on the battery.

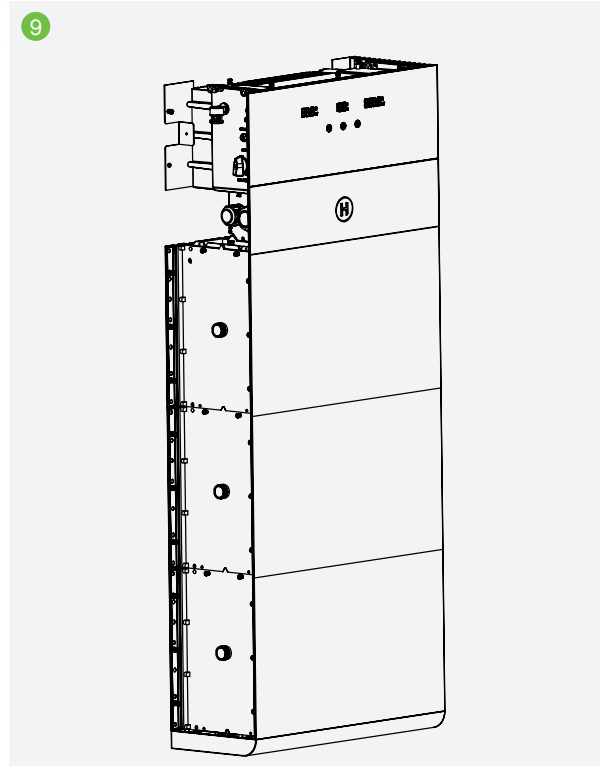
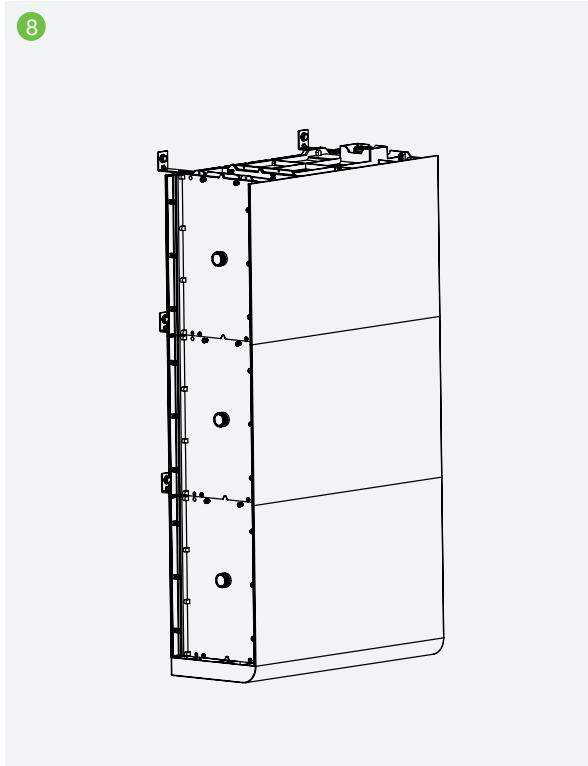

**Step 10** Fix the inverter.

- A. Secure the inverter to the battery using the supplied M4 screws.
- B. Align the two L-shaped brackets with the mounting holes on the inverter, then fasten them using M4 screws.
- C. Align the L-shaped brackets with the drilling positions.
- D. Insert the screws through the brackets into the sleeves and tighten them to secure the inverter to the wall.

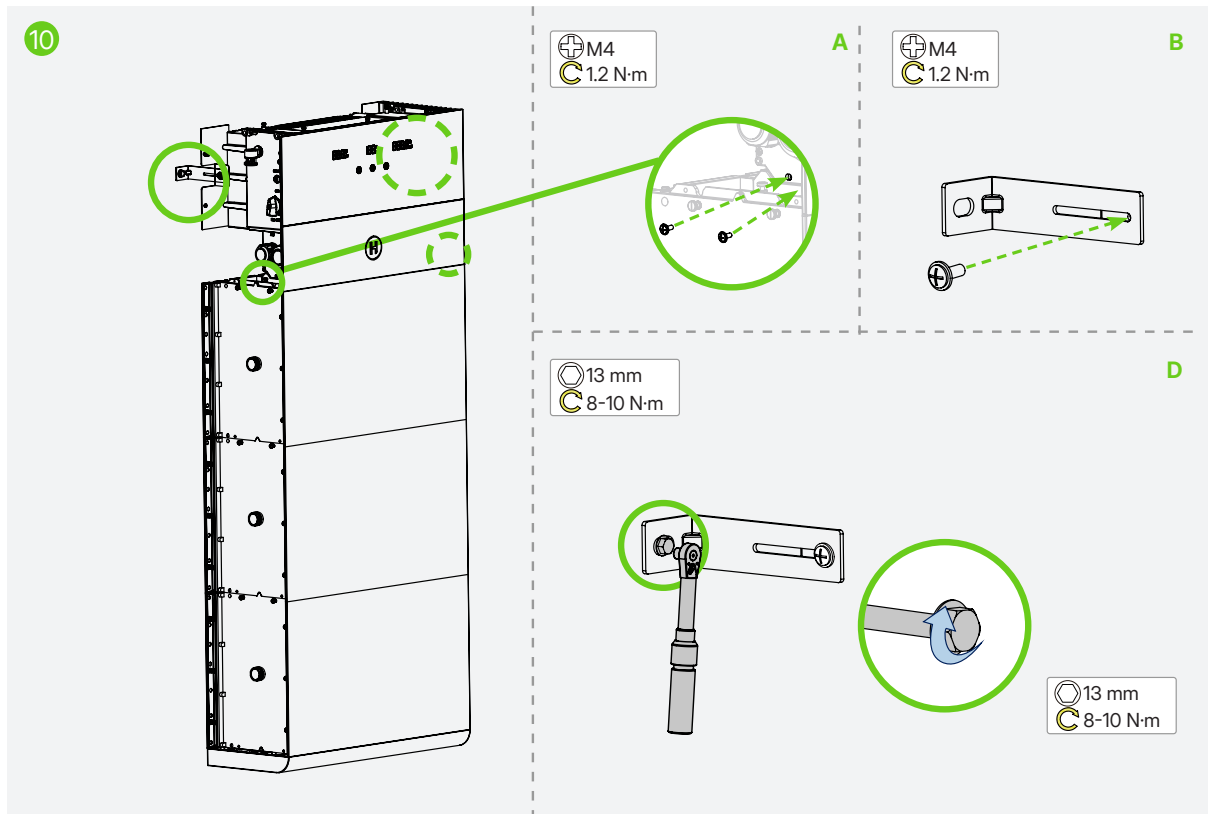
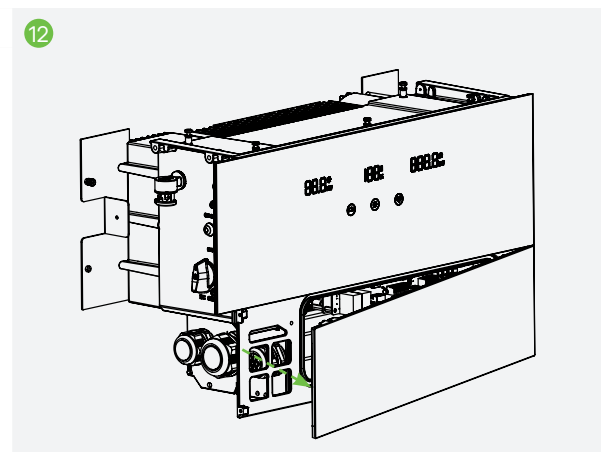
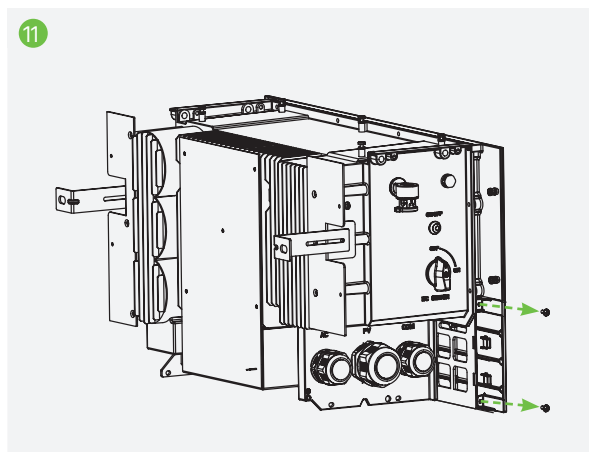
**Step 11** Unscrew the two screws on the left side of the inverter.**Step 12** Open the wiring box cover.

## 7.2 Wall-mounting Installation

### Prerequisite: Level the Base

The base includes a built-in bubble level at its center. If the bubble is centered, the base is level.

If not, the base is uneven. Use flat-head screws to adjust the base height until the bubble is centered and the base is level.

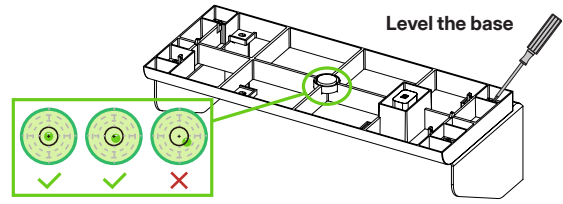

### Step 1 Install the Wall-Mounting Bracket

- A. Attach the two wall-mounting brackets to the base.
- B. Place the bracket assembly against the wall and adjust it until the level bubble is centered.
- C. Mark the drilling positions through the bracket holes, then drill the holes.
- D. Insert the expansion bolts and tighten them to secure the wall-mounting brackets to the wall.

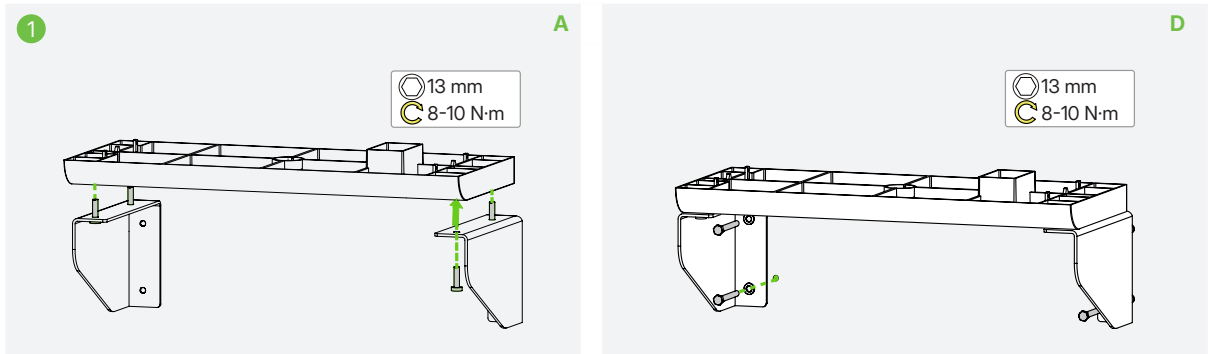

### Step 2 Install the First Battery

- A. Use the Positioning Board to mark the drilling positions.
- B. Drill the holes.
- C. Remove the connector cap from the top of the base.

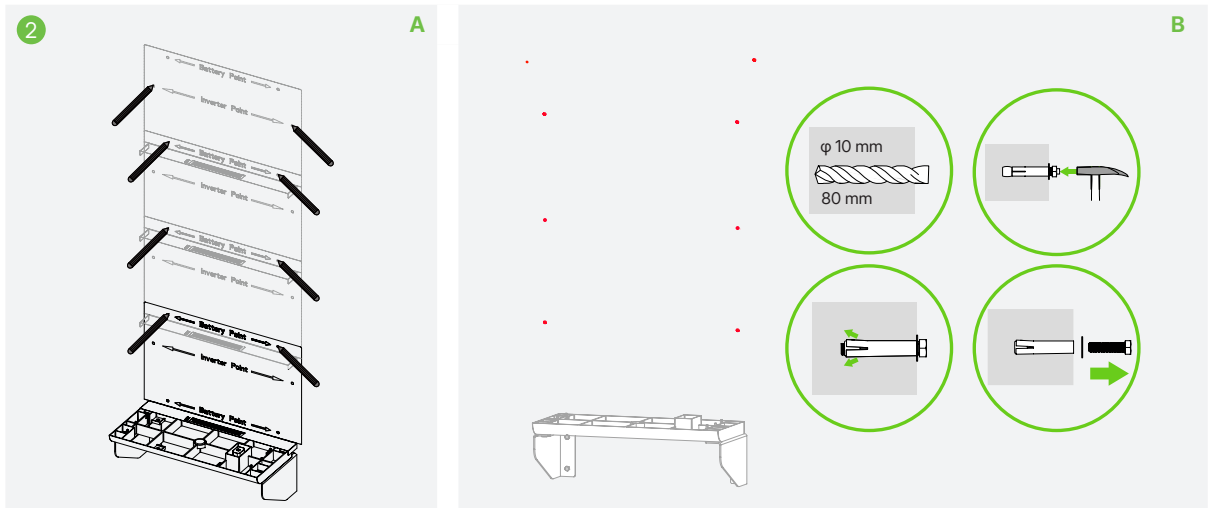

### Tips: How to Use the Positioning Board?

The positioning board has a specific section that is designed to be bent. You need to bend that section first. After bending it, you clip the Positioning Board to the base.

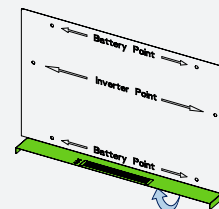

- D. Lift the battery and place it onto the base until the connector fully engages.
- E. Secure the battery to the base with M4 screws.
- F. Secure the battery to the wall using L-shape brackets and M8 expansion screws.

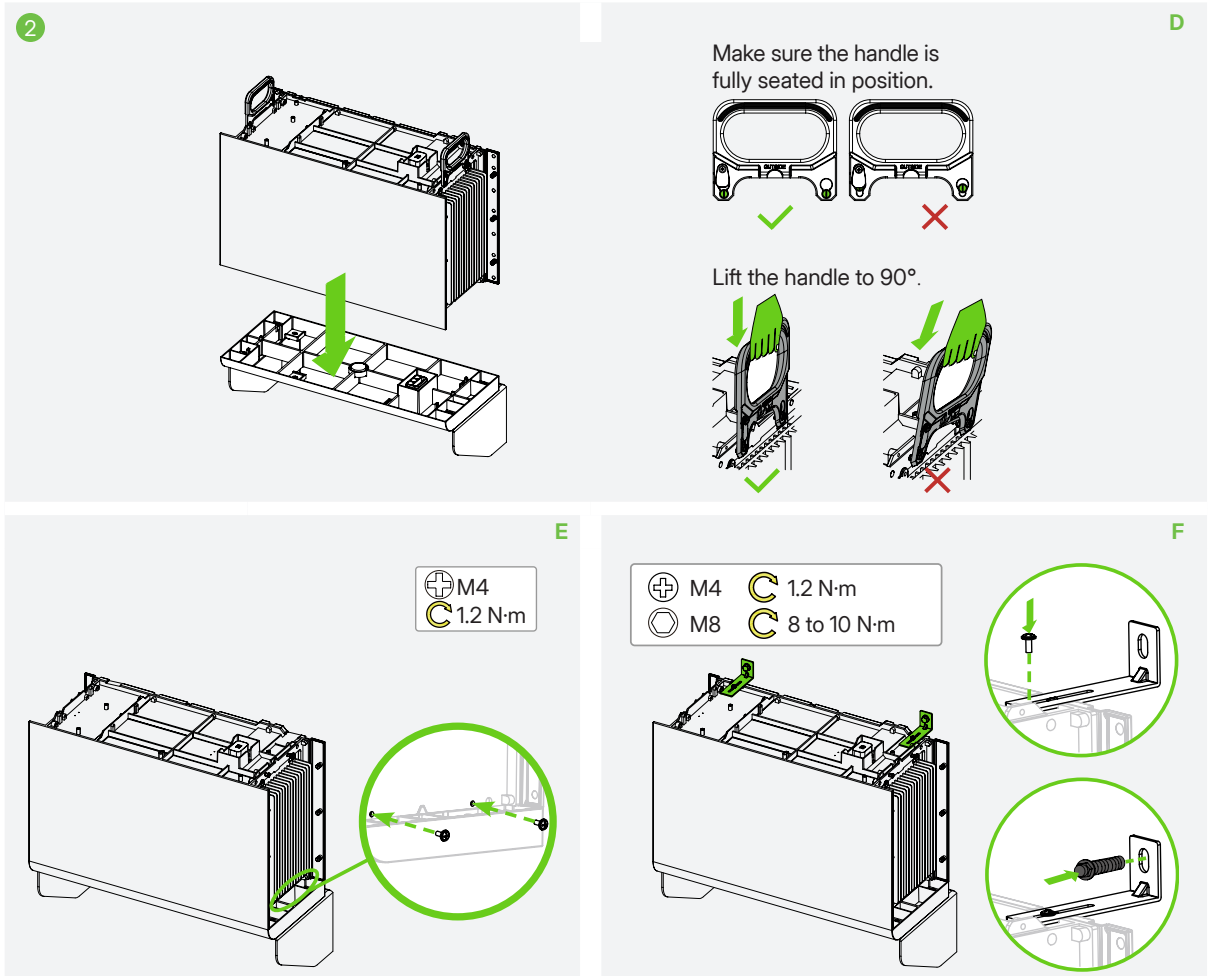

**Step 3 Install Additional Stackable Batteries**

- A. Remove the connector cap from the top of the installed battery.
- B. Lift the battery and lower it onto the previous one until the connectors fully engage.
- C. Secure the two batteries together with M4 screws.
- D. Repeat these steps until all batteries are installed.

**Step 4 Install the Inverter**

- A. Remove the connector cap from the top of the battery and from the bottom of the inverter.
- B. Lift the inverter and place it onto the battery until the connector fully engages.
- C. Secure the inverter to the battery using the supplied M4 screws.
- D. Align the two L-shaped brackets with the mounting holes on the inverter, then fasten them using M4 screws.
- E. Align the L-shaped brackets with the drilling positions.
- F. Insert the screws through the brackets into the sleeves and tighten them to secure the inverter to the wall.

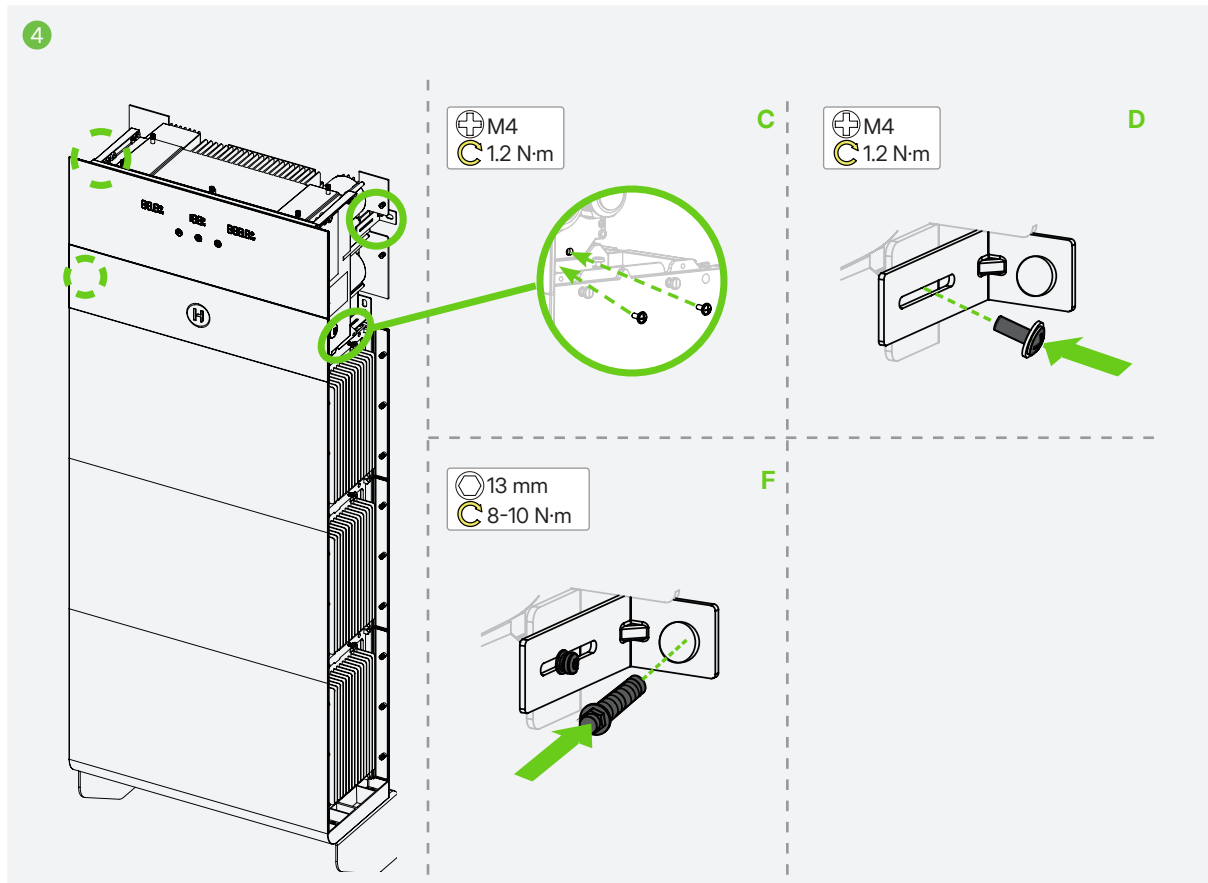

# 8 Electrical Connection

**⚠ WARNING**

- Before any electrical connections, keep in mind that the inverter has dual power supplies.
- Qualified personnel must wear personal protective equipment (PPE) during operation.
- To ensure safe connection and operation, it is recommended to install an overcurrent protection device (circuit breaker) while connecting the AC cable.

## 8.1 Wiring Diagram

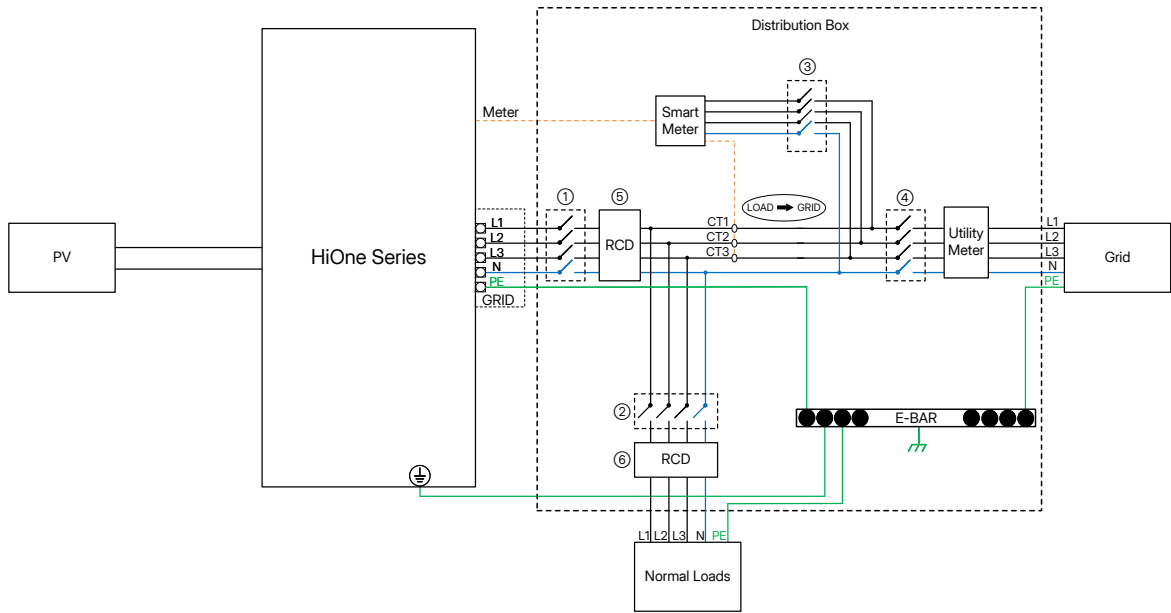

Figure 7-1 Basic System

Model	①	②	③	④	⑤	⑥
HiOne-(8-20)T-G3	63 A/400 V AC Breaker	Depends on Loads	Depends on Meter	Main Breaker	300 mA RCD	30 mA RCD

**NOTE**

- Since Hoymiles inverter has a built-in leakage current detection circuit, it is recommended to use a Type A RCD. If required by local regulations, a Type B RCD is also permitted.
- The three-phase system supports three-phase unbalanced output, and the power of each phase can be controlled individually. Each phase can separately output 1/3 of the rated power of the inverter.
- In the remaining two phases without high power output requirements, any single phase can output 50% of the rated power of the inverter.





## 8.2 Recommended Cable List

The following table provides the cable specifications recommended by Hoymiles. The cables used in actual installation can be larger than the recommended specifications, but cannot be smaller than the recommended specifications. Select the appropriate cables in accordance with local laws and regulations.

**NOTE**

To ensure a reliable electrical connection, it is recommended to use crimp terminals when connecting cables to the inverter.

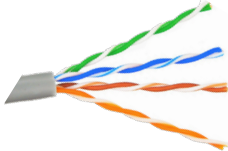
Cable (90°C, Copper)	Recommended Specification (mm <sup>2</sup> )			Stripping Length (mm)
	HiOne-8/10T-G3	HiOne-12/16T-G3	HiOne-20T-G3	HiOne-8/10/12/16/20T-G3
Ground	2.5	4	6	12
AC	2.5	4	6	18
PV	4			12
COM1	Standard CAT 5E/CAT 6 Ethernet Cable			/
COM2	0.5-0.8			11

Cable	Picture	Type
Ground		Yellow-green cable
AC		Five-core copper cable
PV		Dedicated PV cable with a voltage rating of more than 1000 V, a temperature resistance of 105°C, and a fire resistance grade of VW-1
COM1		Standard CAT 5E/CAT 6 Ethernet cable
COM2		Two-core signal cable

### 8.3 Internal overview

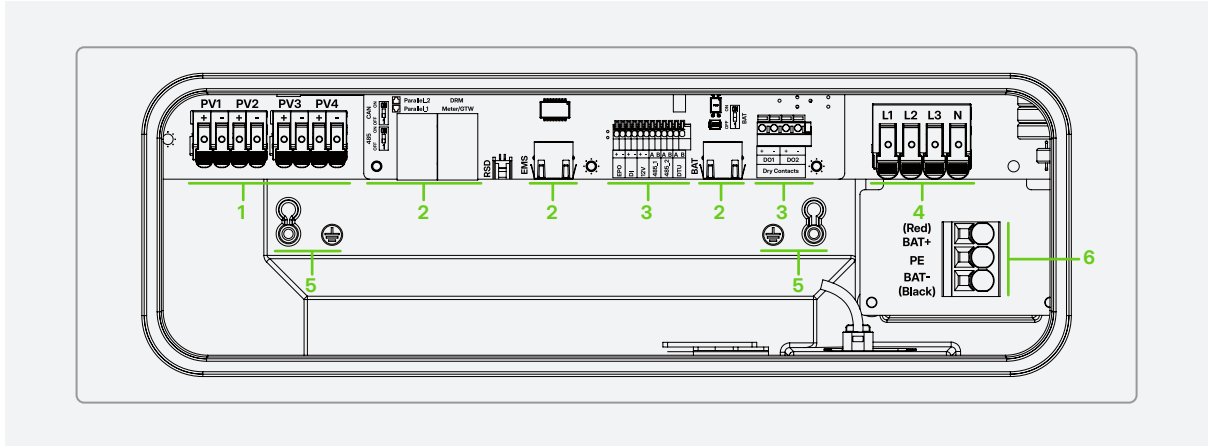

Figure 7-2 Internal Overview

NO.	Description
1	PV Terminals
2	Communication Terminals (COM1)
3	Communication Terminals (COM2)
4	AC Terminals
5	Ground Terminals
6	Battery Terminals

### 8.4 Ground Cable Connection

Cable (90°C, Copper)	Recommended Specification (mm <sup>2</sup> )					Stripping Length (mm)
	HiOne-8T-G3	HiOne-10T-G3	HiOne-12T-G3	HiOne-16T-G3	HiOne-20T-G3	HiOne-8/10/12/16/20T-G3
Ground	2.5		4		6	12

**Step 1** Crimp the cable and ground terminal.

**Step 2** Connect the ground cable to the inverter.

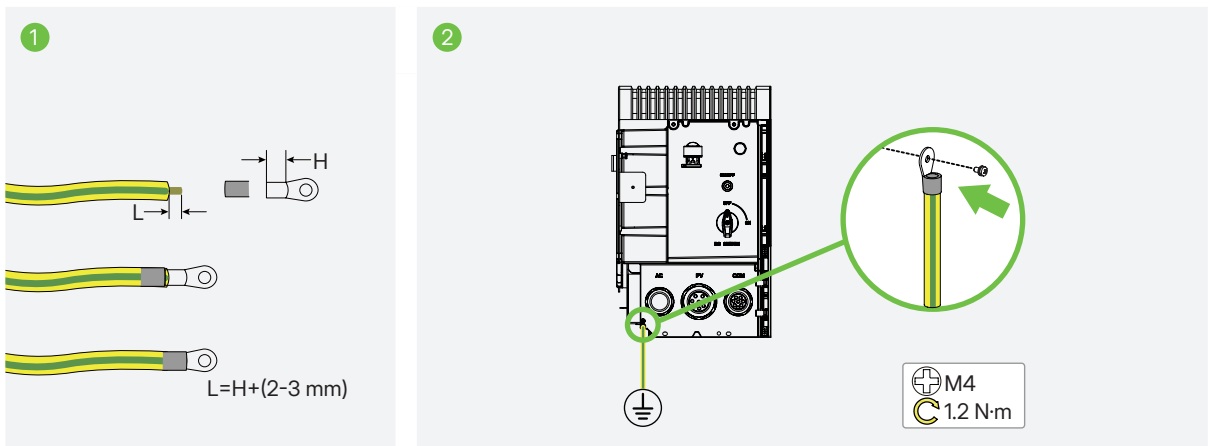

## 8.5 AC Cable Connection

### ⚠ WARNING

Before connecting the AC cable, please make sure all requirements listed below are followed.

- An independent three or four-pole circuit breaker must be installed on the output side of the inverter to ensure safe disconnection from the grid.
- Multiple inverters cannot share one circuit breaker.
- Never connect a load between the inverter and the circuit breaker.
- Make sure that the overcurrent protection devices (OCPDs) (breakers) are turned off.
- Ensure the rated power of the EPS load does not exceed the rated output power of the inverter.
- Ensure that the starting power of inductive loads, such as air conditioners, refrigerators, and pumps, does not exceed the EPS peak power of the inverter. (The starting power of the air conditioner is at least 2 times the rated power. For details, refer to the appliance manual.) Otherwise, the inverter will stop output or even shut down with a fault alarm.
- Before proceeding to the next step, make sure that the AC voltages are 0 Vac through a multimeter.

### 📌 NOTE

- The colors for L1, L2, L3, N, and PE wires used in this manual are L1-Brown, L2-Black, L3-Grey, N-Blue, and PE-Yellow&Green.
- The wiring color code may vary. Please follow local laws and regulations for wiring.

### Before You Start

The product has two grounding lugs. Which one you can use depends on the product version. On early versions, one lug is already connected to the battery cable, so use the other lug for grounding. On later versions, both lugs can be used, and you may choose either one.

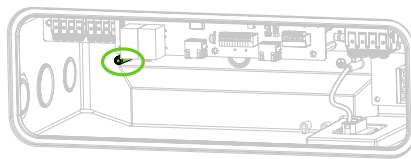

Early Version

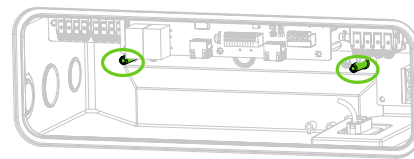

Later Version

### Procedure

Cable (90°C, Copper)	Recommended Specification (mm <sup>2</sup> )					Stripping Length (mm)
	HiOne-8T-G3	HiOne-10T-G3	HiOne-12T-G3	HiOne-16T-G3	HiOne-20T-G3	HiOne-8/10/12/16/20T-G3
AC	2.5		4		6	18

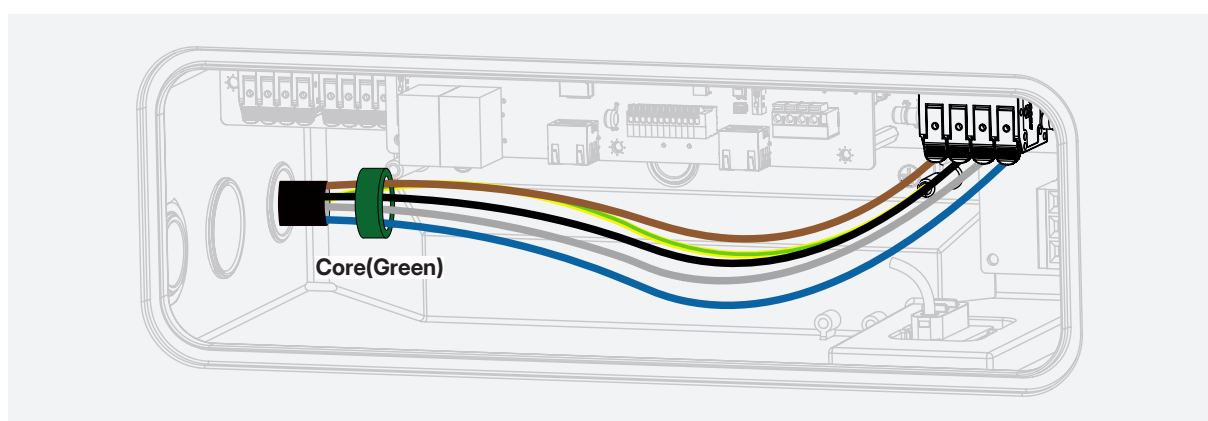

- Step 1** Strip the insulation of L1/L2/L3/N/PE wires by 18 mm.
- Step 2** Crimp the ground cable and the ground terminal.
- Step 3** Unscrew the cable gland on the left side of the inverter.

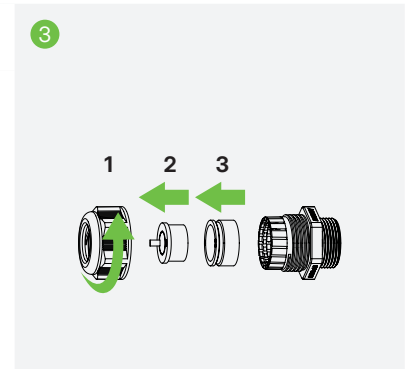
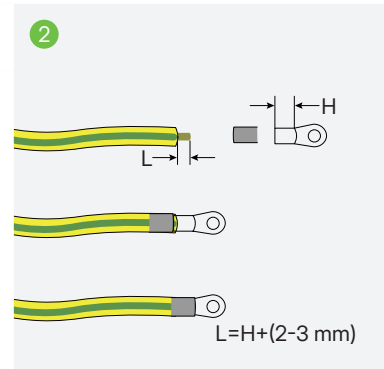
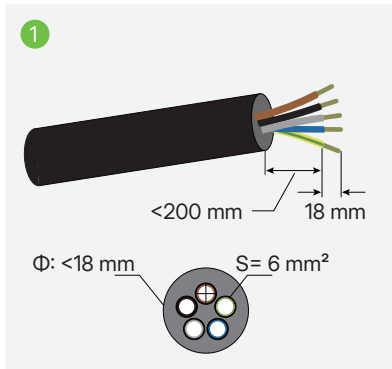

- Step 4** Thread the AC cable through the AC cable entry.
- Step 5** Connect the PE wire to the PE terminal.
- Step 6** Raise the locking clip.
- Step 7** Insert the L1/L2/L3/N wires into the corresponding terminals.
- Step 8** Pull the locking clip downward to lock the connection. Gently pull the wires backward to ensure that they are firmly connected, and tighten the cable gland with a torque of 7 N·m to 8 N·m.

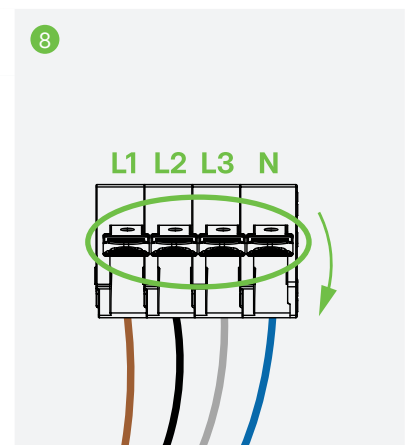
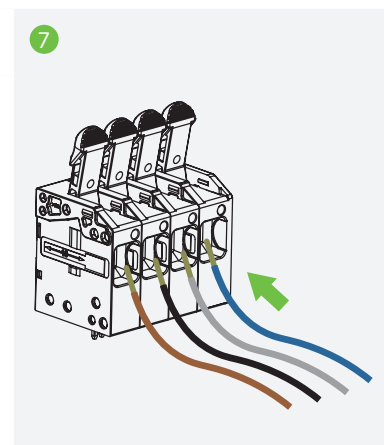
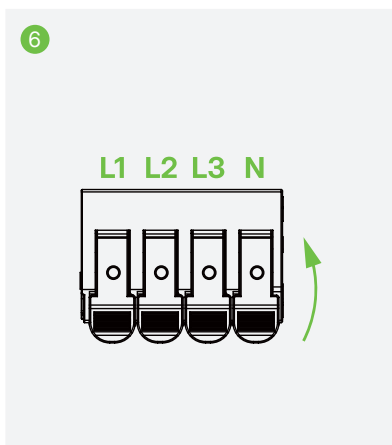
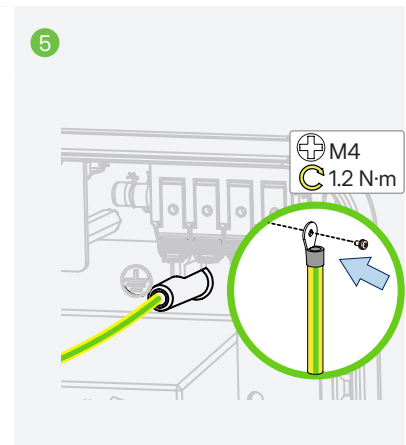
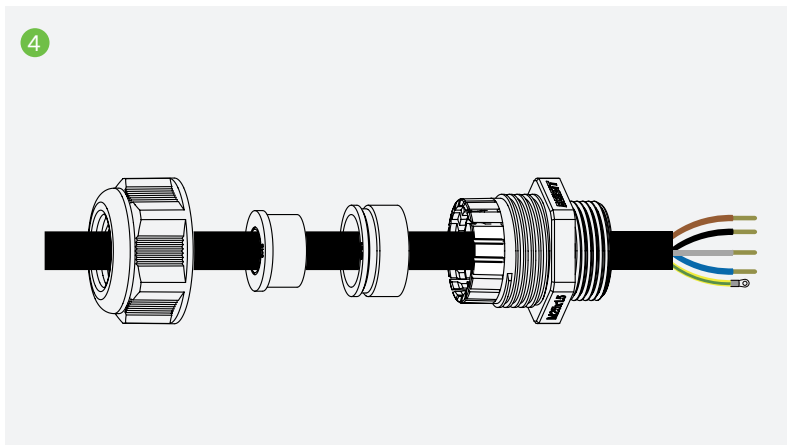

## 8.6 PV Cable Connection

**⚠ WARNING**

Before connecting the PV cables, please make sure all requirements listed below are followed.

- The voltage, current, and power ratings of the panels to be connected are within the allowable range of the inverter. Ensure the polarity is correct, and please refer to the technical parameters in [13 Technical Datasheet](#) for voltage and current limits.
- If the PV cables are reversely connected or if the equipment is not working properly, do not turn off the DC switch. Otherwise, it may cause a DC arc, fire, or damage to the inverter. After the PV input current drops below 0.5 A, disconnect the DC switch and adjust the polarity of the PV strings.
- Since the equipment is a transformerless structure, please do not ground the outputs of PV panels.

Cable (90°C, Copper)	Recommended Specification (mm <sup>2</sup> )	Stripping Length (mm)
		HiOne-8/10/12/16/20T-G3
PV	4	12

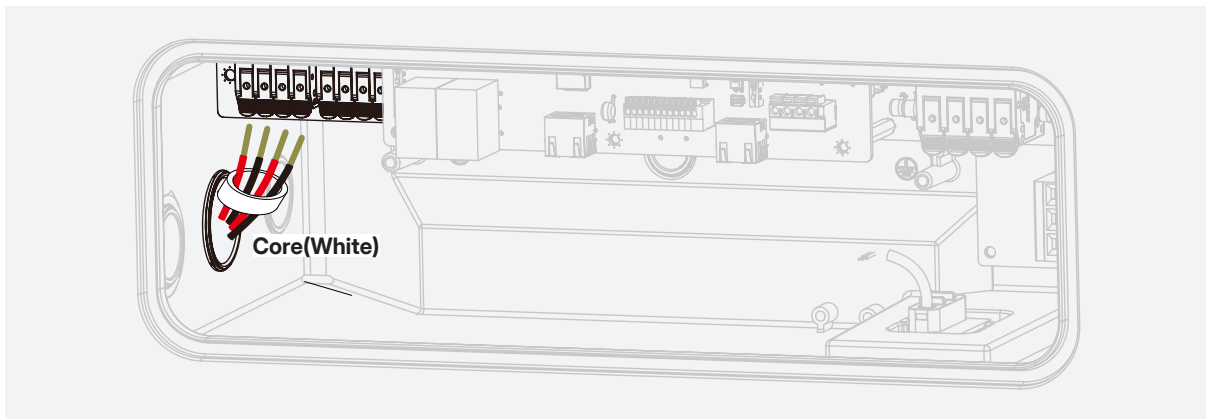

**Step 1** Strip the insulation of PV cables by 12 mm, unscrew the cable gland on the left side of the inverter, and remove the rubber plugs.

**Step 2** Thread the PV cables through the PV cable entry.

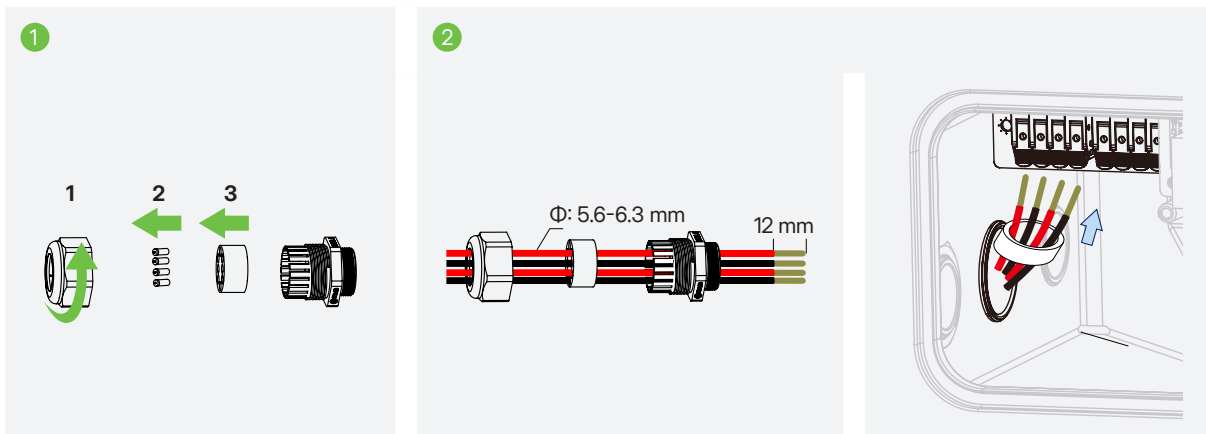

**Step 3** Raise the locking clip.

**Step 4** Insert the PV cables into the corresponding terminals.

**Step 5** Pull the locking clip downward to lock the connection. Gently pull the wires backward to ensure that they are firmly connected, and tighten the cable gland with a torque of 10 N·m to 13 N·m.

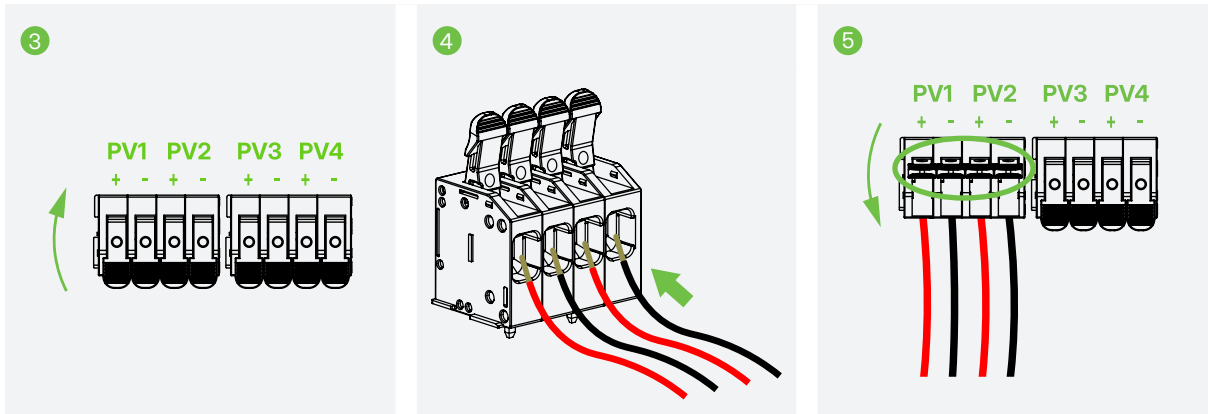

**NOTE**

To ensure sealing performance, remove the rubber plugs based on the actual number of cables.

## 8.7 (Optional) Battery Cable Connection

If the second battery tower needs to be installed, use the provided cable to connect the second battery tower to the inverter.

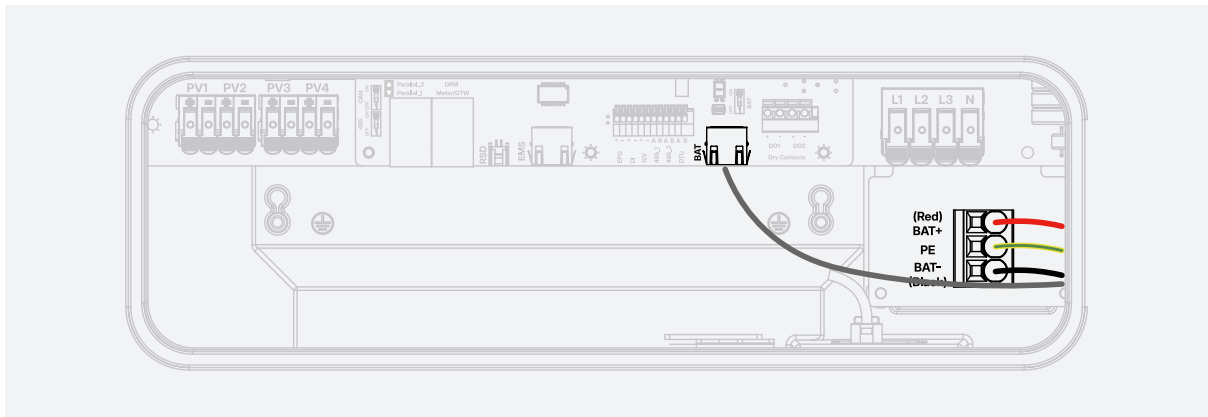

**Step 1** Follow the instructions in [7 Installation Steps](#) to install the second battery tower, and install the five stepped screws on the top of the second battery tower.

**Step 2** Remove the cover on the right side of the inverter.

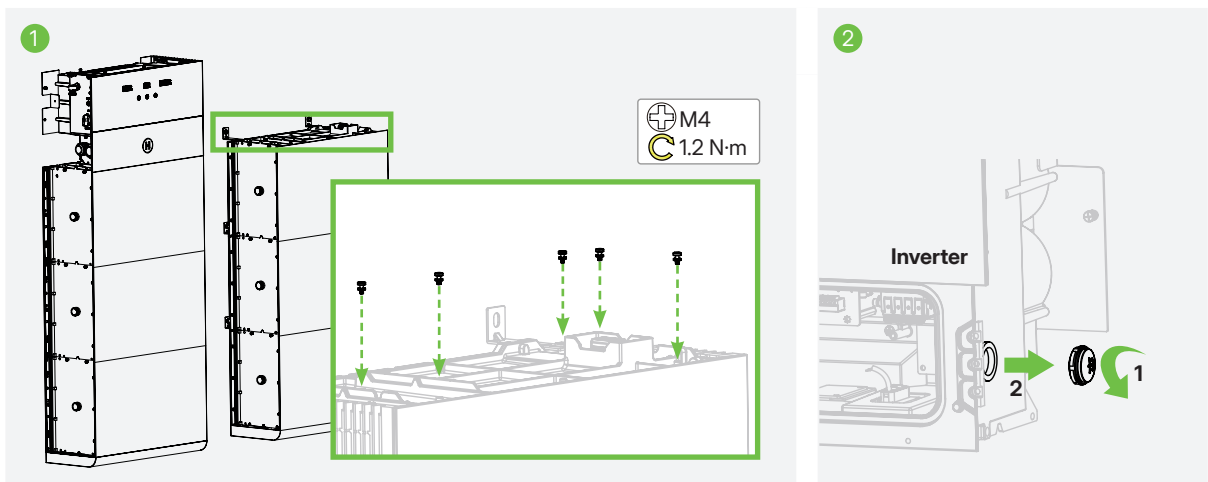

**Step 3** Thread the battery cable through the battery cable entry, and tighten the cable gland.

**Step 4** Insert the positive wire, negative wire, PE wire, and communication wire into corresponding terminals.

**Step 5** Cut off a piece of the decorative cover.

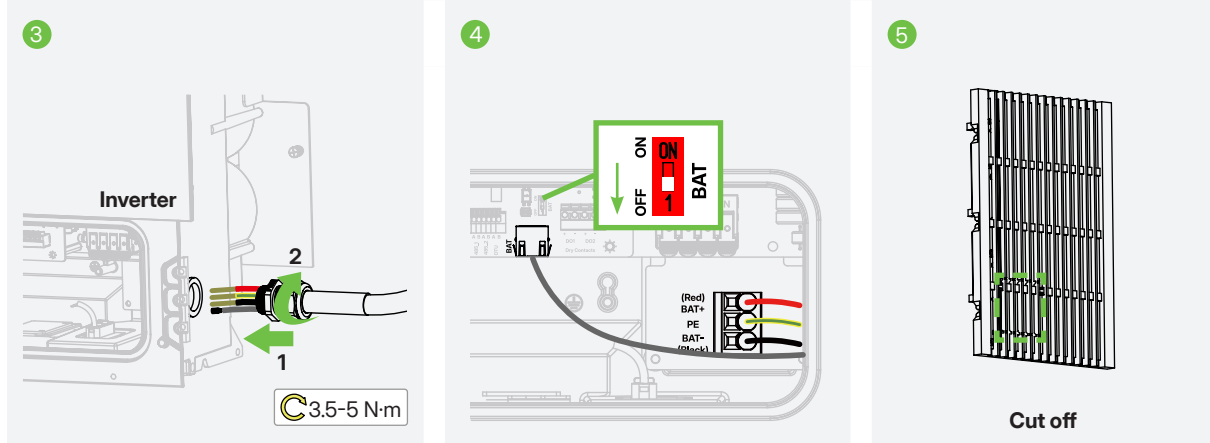

**Step 6** Install the decorative cover on the inverter.

**Step 7** Loosen but do not remove the screw on the battery cable.

**Step 8** Insert the quick connector end of the battery cable into the connector on the top of the second battery tower.

**Step 9** Tighten the screw on the battery cable.

**Step 10** Install the top cover.

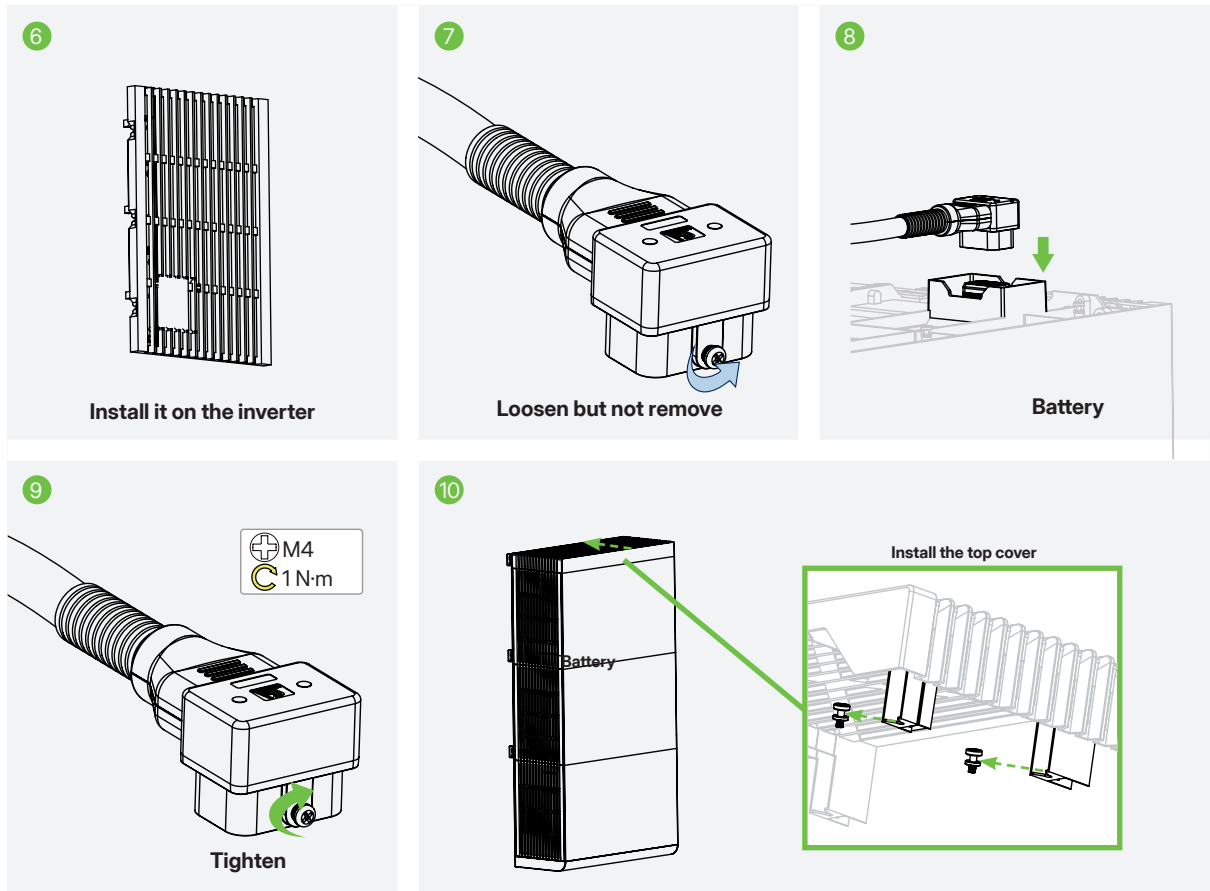

**NOTE**

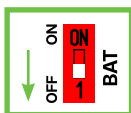

Ensure that this termination resistor is "OFF".

## 8.8 Communication Cable Connection (COM1)

The HiOne system includes one standard communication cable for connecting to the Meter/GTW port. If you need to connect additional devices to COM1, prepare communication cables that meet the recommended cable specifications.

Cable	Recommended Specification (mm <sup>2</sup> )
	HiOne-8/10/12/16/20T-G3
COM1	Standard CAT 5E/CAT 6 Ethernet Cable

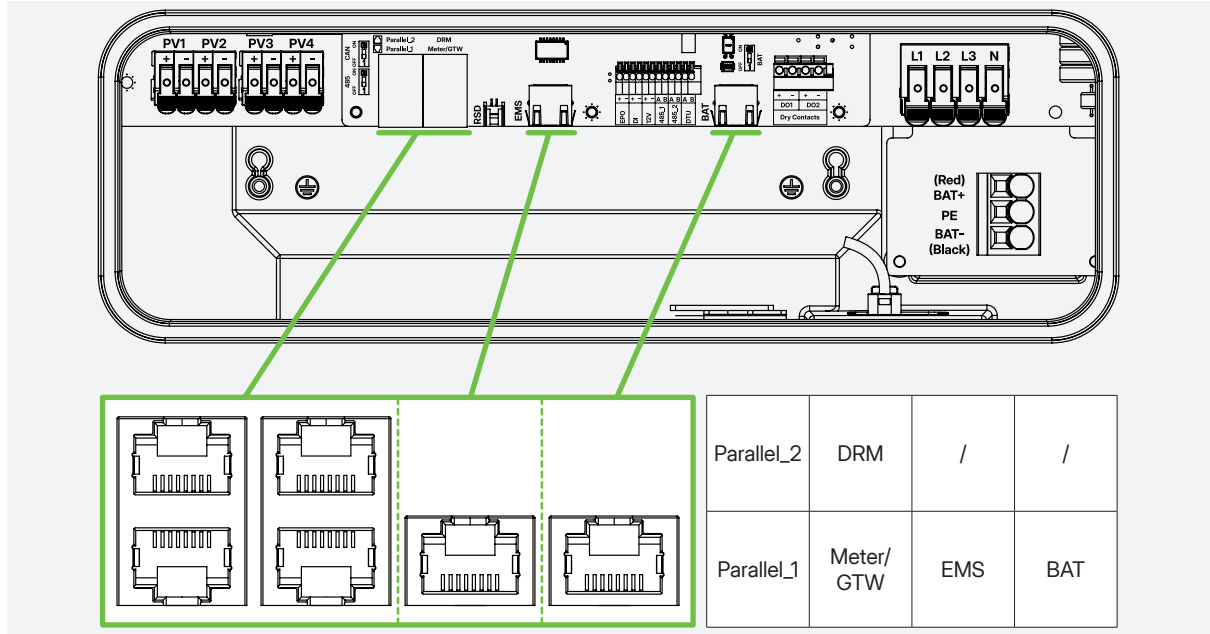
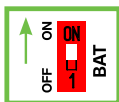

Figure 7-3 COM1 Overview

Terminal	PIN	Definition							
		1	2	3	4	5	6	7	8
Parallel_2	 87654321	NC	GND	CANH	Psync-485A	Psync-485B	CANL	485B	485A
Parallel_1	 12345678	NC	GND	CANH	Psync-485A	Psync-485B	CANL	485B	485A
DRM	 87654321	DRM1/5	DRM2/6	DRM3/7	DRM4/8	REF	COM	NC	NC
Meter/GTW	 12345678	CANH	CANL	GND	485A	485B	GND	+12V1A_OUT	+12V1A_OUT
EMS	 87654321	RX_P	RX_N	TX_P	NC	NC	TX_N	NC	NC
BAT	 87654321	Button 2+	Button 2-	NC	NC	+12V	GND	CANL	CANH

**NOTE**



If the batteries are stacked in one battery tower, ensure that this termination resistor is "ON".

**Step 1** Unscrew the cable gland, and remove the rubber plugs.

**Step 2** Thread the cable through the communication cable entry at the left side of the inverter.

**Step 3** Insert the RJ45 plug into the corresponding terminal until it clicks into place, and tighten the cable gland.

**NOTE**

- Tighten the cable gland with a torque of 6.75 N·m to 7.5 N·m after completing the wiring.
- If the wiring is incorrect, the system will work abnormally. Reconnect cables according to the PIN definition described above.

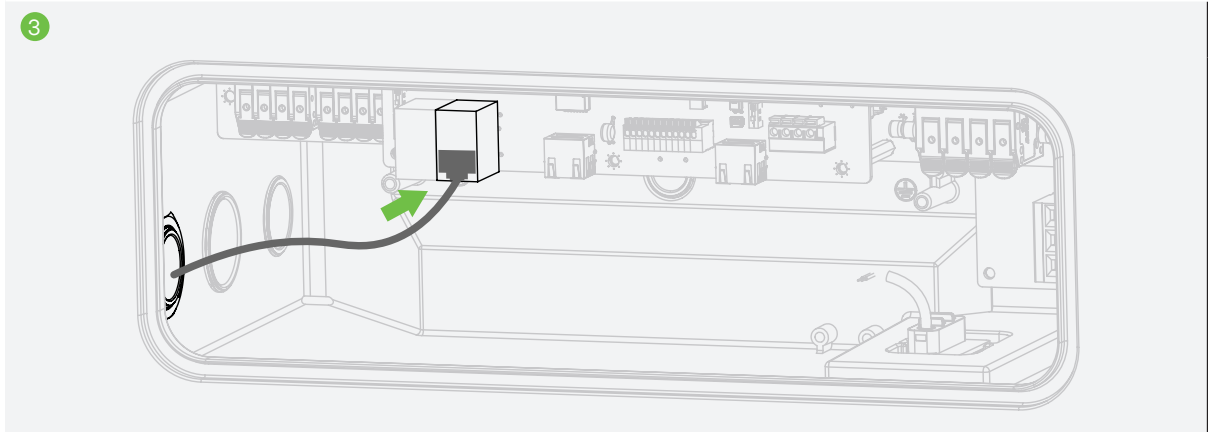



### 8.8.2 DRM Connection

DRM is designed to support several demand response modes by certain control signals.

**NOTE**

After completing the DRM connection, log in to the S-Miles Installer App to enable the DRM function and set the mode of **DRM Control** according to the actual installation. For detailed instructions, refer to [10.3.2 Enable DRM Function](#).

- For Australia and New Zealand**

According to AS/NZS 4777.2, the inverter needs to support the function of demand response mode (DRM). With the use of an external control box, active or reactive power regulation can be realized in a timely and fast manner, and the inverter can work stably during the process of regulation.

**Demand Response Modes**

Function	Description
DRM0	Operate the disconnection device
DRM1	Do not consume power
DRM2	Do not consume at more than 50% of rated power
DRM3	Do not consume at more than 75% of rated power AND supply reactive power if capable
DRM4	Increase power consumption (subject to constraints from other active DRMs)
DRM5	Do not generate power
DRM6	Do not generate at more than 50% of rated power
DRM7	Do not generate at more than 75% of rated power AND absorb reactive power if capable
DRM8	Increase power generation (subject to constraints from other active DRMs)

**DRED Connection Circuit**

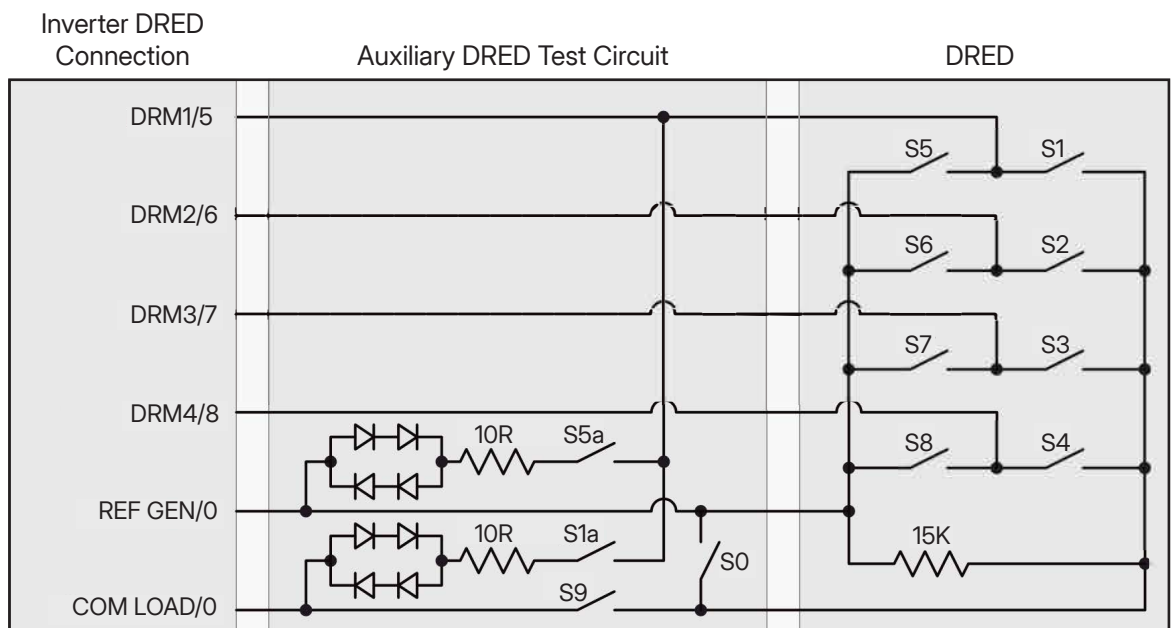

Figure 7-4 DRED Connection

- **For Germany**

In Germany, the inverters are required to respond to control signals from the grid company via a Ripple Control Receiver (RCR). The RCR converts dispatch signals from the grid operator into dry contact signals, which the inverter uses to limit its feed-in power as instructed.

The internal wiring and operation description are shown in the figure below.

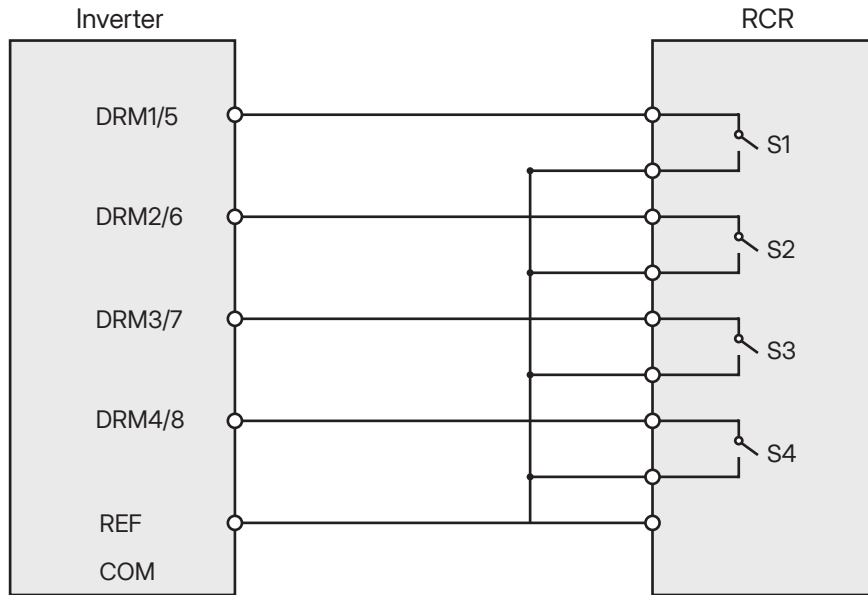

Figure 7-5 RCR Connection

S1	S2	S3	S4	RCR Operation	Output power (100% Rated Output Power)
0	0	0	0	None	100% (Unlimited)
1	0	0	0	Close S1	100%
0	1	0	0	Close S2	60%
0	0	1	0	Close S3	30%
0	0	0	1	Close S4	0

- **For Austria**

An external contactor should be connected to DRM4/8 and REF. Select a NO contactor or a NC contactor as required.



- Step 1** Strip the insulation of the communication cable by 11 mm.
- Step 2** Unscrew the cable gland and remove the rubber plugs.
- Step 3** Thread the cable through the communication cable entry on the left side of the inverter.
- Step 4** Connect the cable.
  - a. Insert a screwdriver to press down the leaf spring.
  - b. Insert the wires into the corresponding terminals, and remove the screwdriver.
  - c. Gently pull the wires backward to ensure that they are firmly connected, and tighten the cable gland with a torque of 6.75 N·m to 7.5 N·m.

**NOTE**  
To ensure sealing performance, remove the rubber plugs based on the actual number of cables.

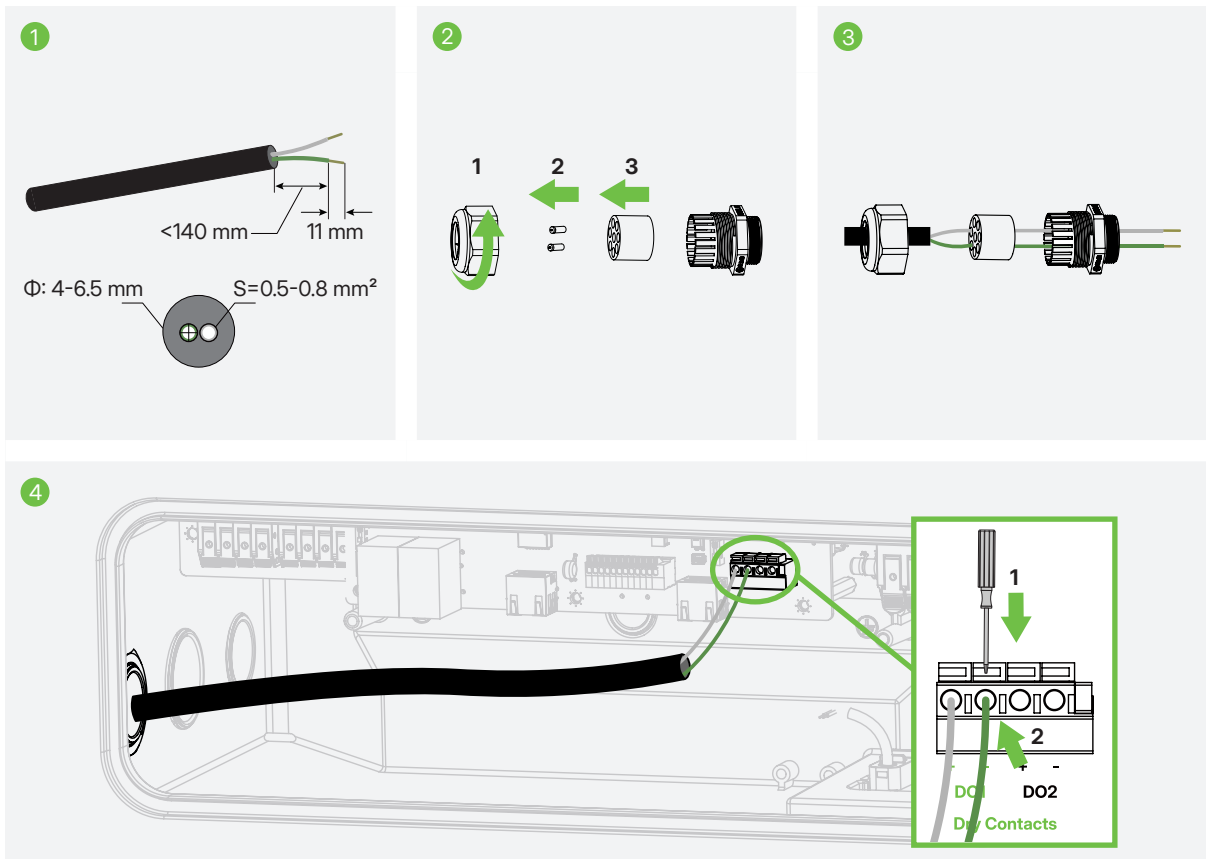

## 8.10 Installing the Wiring Box Cover

- Step 1** Put back the wiring box cover.
- Step 2** Insert the screws into the screw holes, and tighten the screws.

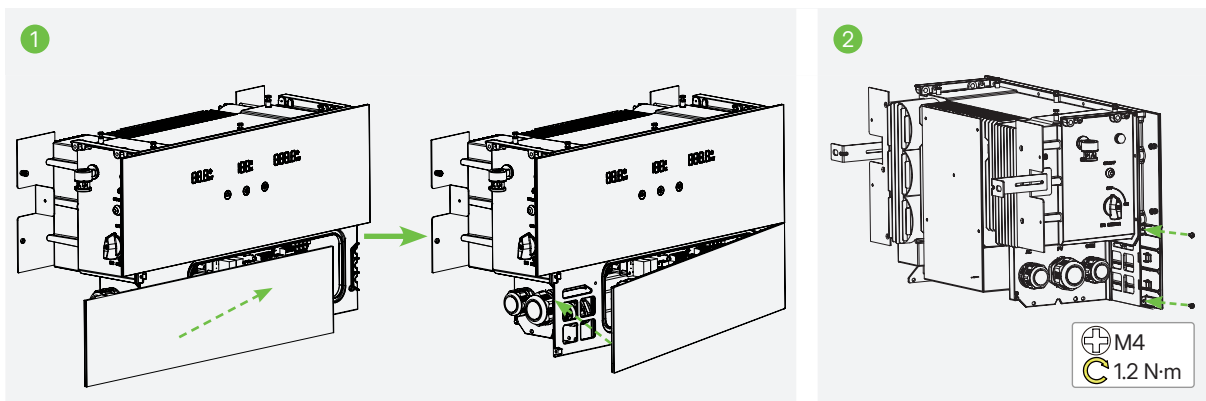

## 8.11 Installing the Data Transfer Stick (DTS)

### 8.11.1 DTS-WL-G3 (Wi-Fi Mode)

**Step 1** Remove the cover of the DTS terminal.

**Step 2** Insert the DTS into the DTS terminal. There will be a "Click" sound when it is plugged in correctly.

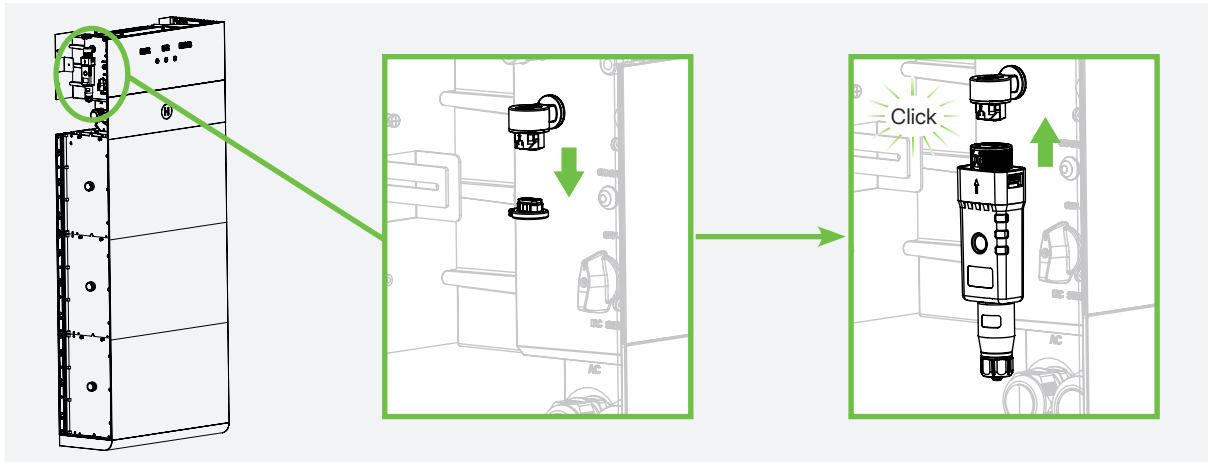

### 8.11.2 DTS-WL-G3 (LAN Mode)

**Step 1** Disassemble the DTS in sequence.

**Step 2** Thread the Ethernet cable through the parts and tighten them.

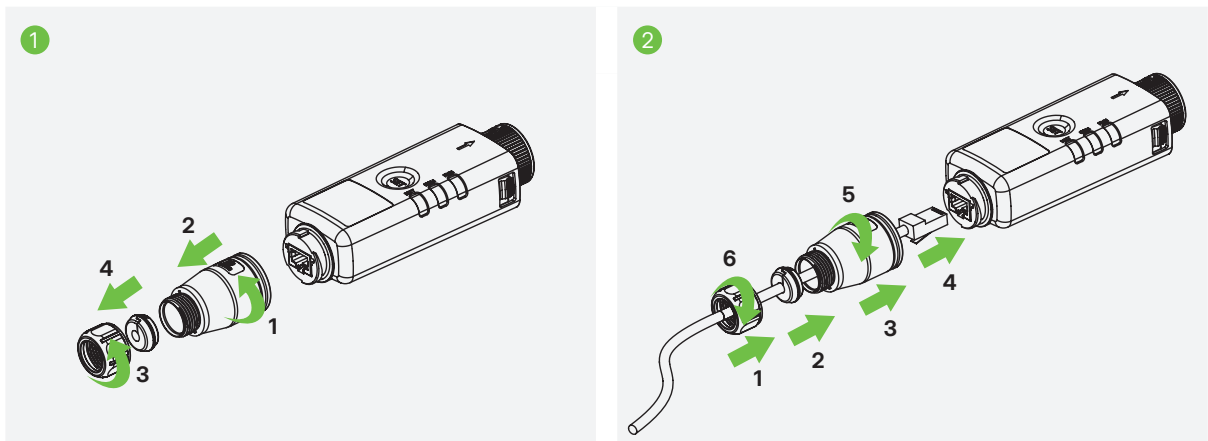

**Step 3** Remove the cover of the DTS terminal, and then insert the DTS into the DTS terminal. There will be a "Click" sound when it is plugged in correctly.

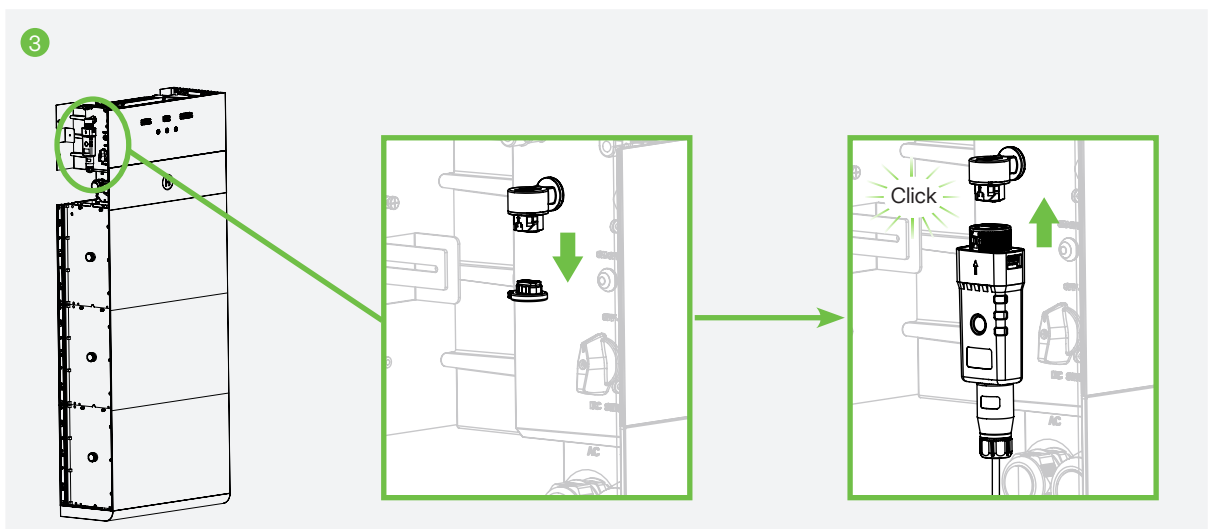

## 9 System Commissioning

### 9.1 Preparation

Before the commissioning of the product, make sure:

- The inverter DC switch and external circuit breaker are disconnected.
- The DIP switch is in the "OFF" State.
- The wiring follows the instructions in [8 Electrical Connection](#).
- The grid voltage is within the permissible range through the multimeter before turning on the AC switch.
- The rubber plugs in the unused terminals are not removed.
- Nothing is left on the top of the product.
- Cables are routed in a safe place or protected against mechanical damage.
- Warning signs and labels are intact.

### 9.2 System Power-on

**Step 1** Turn on the AC breaker between the inverter and the grid.

**Step 2** Rotate the DC switch to "ON" if the inverter is connected to the PV strings.

**Step 3** (Optional) Press the power button on the left side of the inverter to activate the battery if the battery SOC is lower.

**Step 4** Verify that the inverter is operating properly by checking the [indicator status](#).  
Decorative Cover Installation

**Step 1** Install the decorative covers on the left and right sides.

**Step 2** Install the top cover.

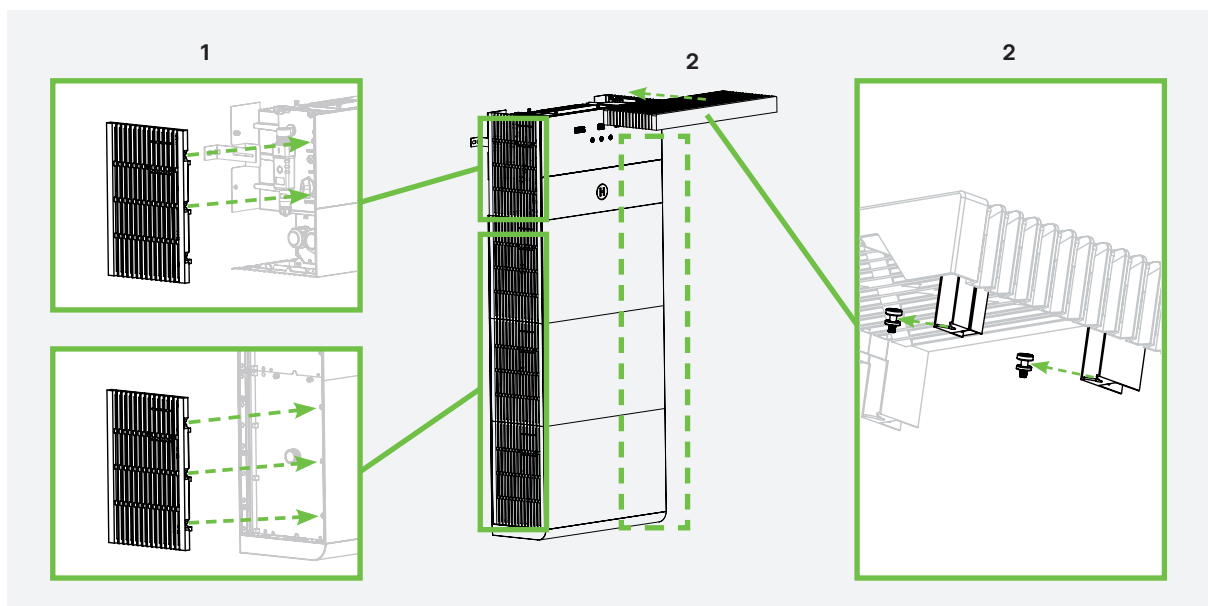

# 10 S-Miles Cloud

The S-Miles App has been developed for Hoymiles and offers the following features.

- a. Network configuration
- b. Local installation assistant
- c. System monitoring

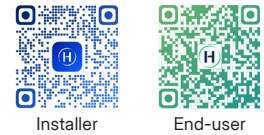

Please download the S-Miles App from the Google Play Store or the App Store. The QR code above can also be scanned to download the App.

**NOTE**

- The DTU mentioned in this manual refers to the DTS (Data Transfer Stick).
- In a residential energy storage system, the DTU displayed in the S-Miles Cloud refers to the DTS.
- The screenshots shown in this manual are for reference only. Since the App version will be updated periodically, the interface displayed on your screen may differ.
- For more information about S-Miles App, refer to [S-Miles Cloud User Manual \(App\)](#).

## 10.1 Start Commissioning

**Commissioning** is used to set and test a new residential energy storage system. It is critical step to ensure that a new device and system can function properly according to the design specifications. During commissioning, you will:

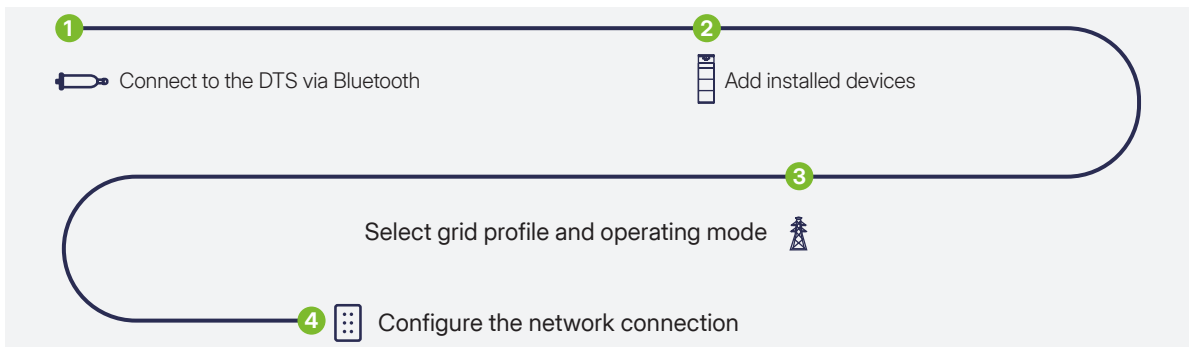

### Step 1 Connect to the DTS

- A. Tap **O&M** > **Toolkit**.
- B. Under **Via Bluetooth**, tap the DTS you want to connect.
- C. Enter the default password **123456**, then tap **Confirm**.

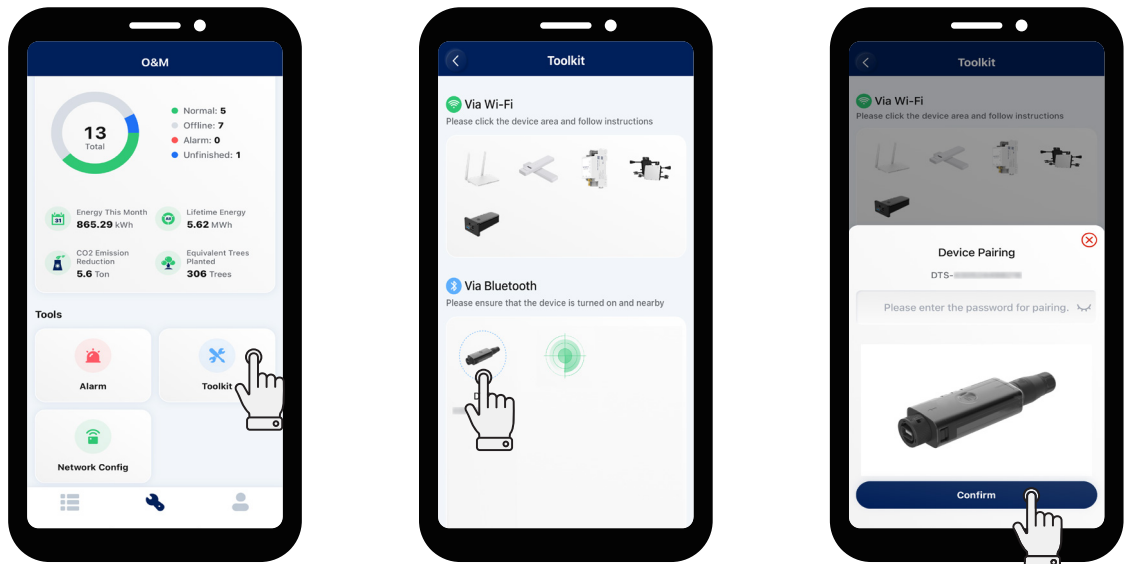

D. Tap **Go to Settings**.

**NOTE**  
Password setup is required only for the first connection.

E. Enter the current password and a new password, confirm the new password, and tap **Send to DTU**.

F. Tap **Toolkit** again.

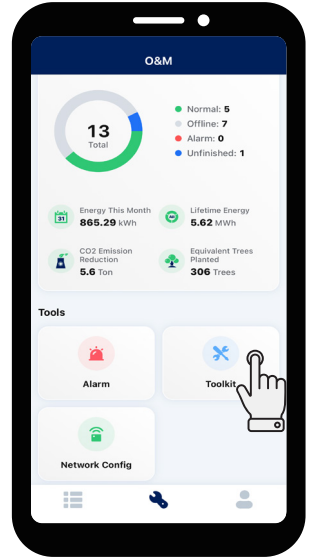
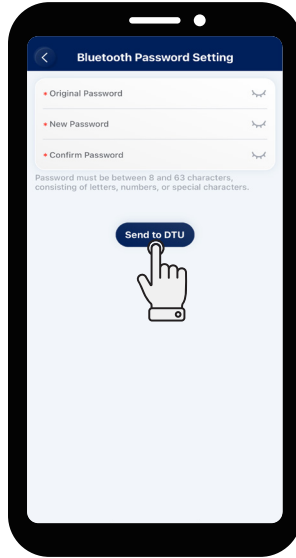
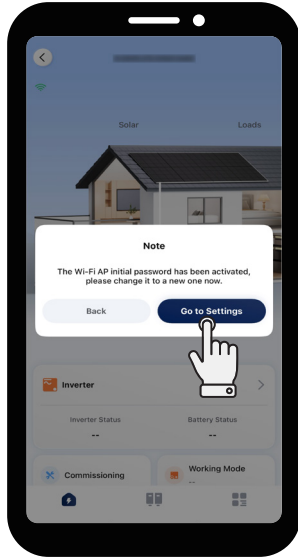

G. Under **Via Bluetooth**, tap the DTS again.

H. Enter the new password and tap **Confirm**.

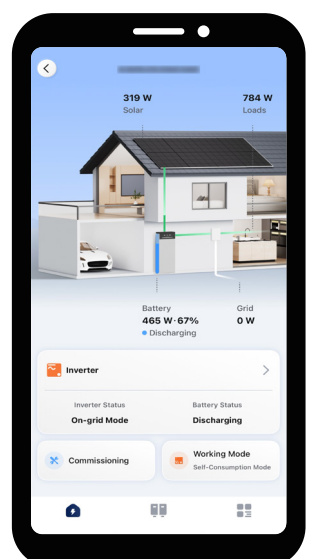
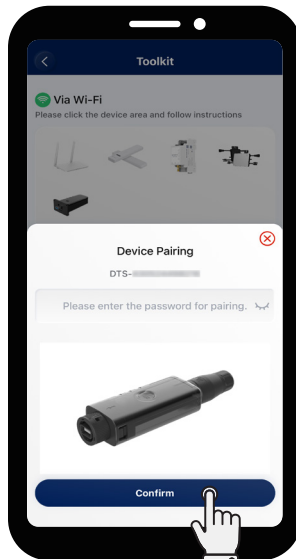
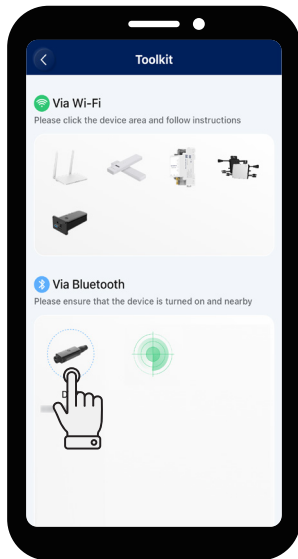

## Step 2 Start Commissioning

A. Tap **Toolkit** > **Commissioning**.

B. Follow the on-screen instructions and add devices based on your actual installation, then tap **Next**.

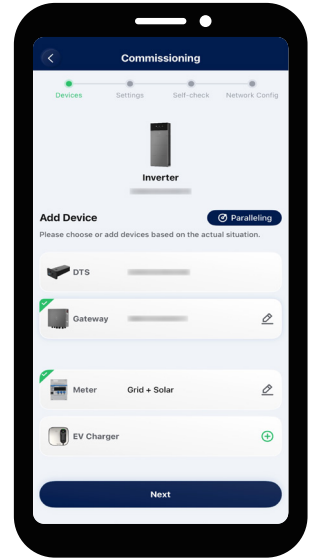
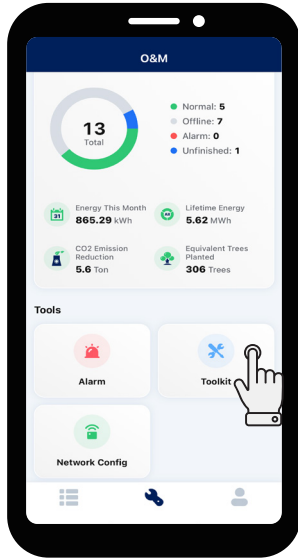

- **Parallel system**

If a parallel system is installed, tap **Paralleling**. All slave inverters will be added automatically.

**NOTE**

- The DTS must be connected to the master inverter.
- Slave inverters must be connected to the master via communication cables.
- One DTS supports communication with up to 10 inverters.

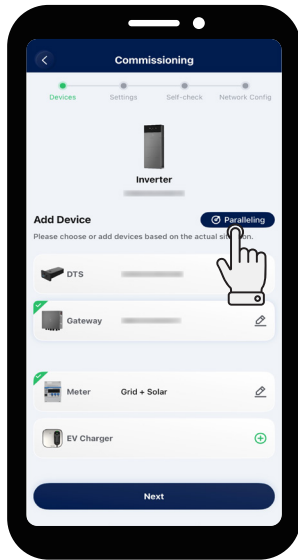

- **Gateway**

If a Hoymiles gateway is installed, tap **Gateway**, set the required parameters, and tap **Save**.

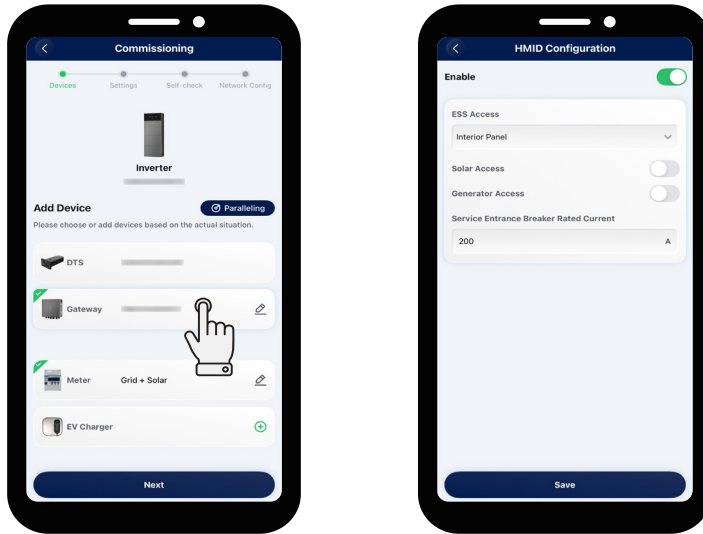

- **Meter**

Tap **Meter**, enable **Meter Settings**, select the meter location according to the installation, and tap **Save**.

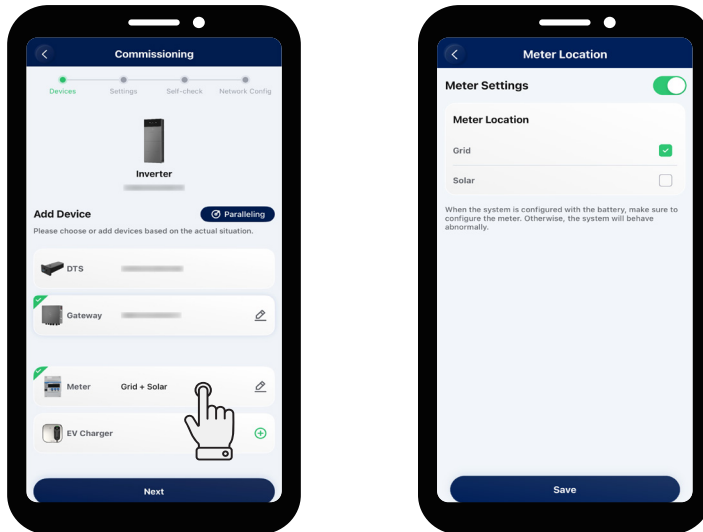

- **EV Charger**

If an EV charger is installed, tap **EV Charger**. You can tap **Auto Search** or scan the QR code on the label to identify the serial number (SN), and tap **Save**.

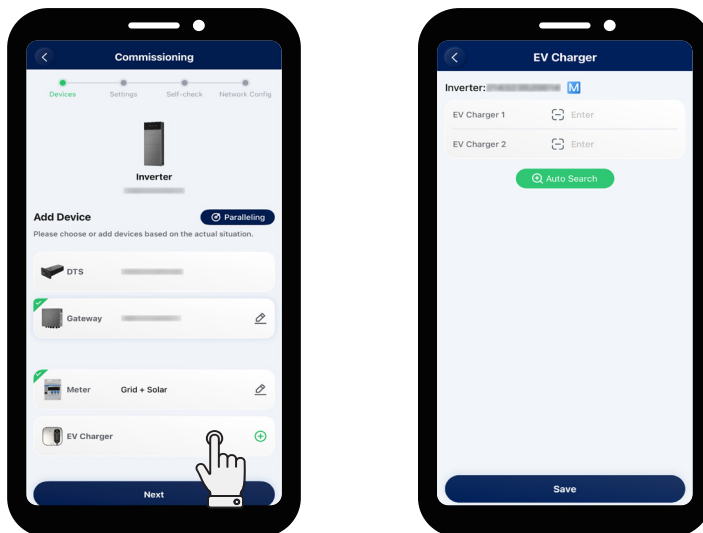

C. Configure system settings.

- Select the grid profile for your region, then tap **Next**.
- Select the required working mode, then tap **Next**. For details, see [4.4 Working Modes](#).
- Select **Generator**, **Inverter**, or **None** based on the installation, then tap **Next**.

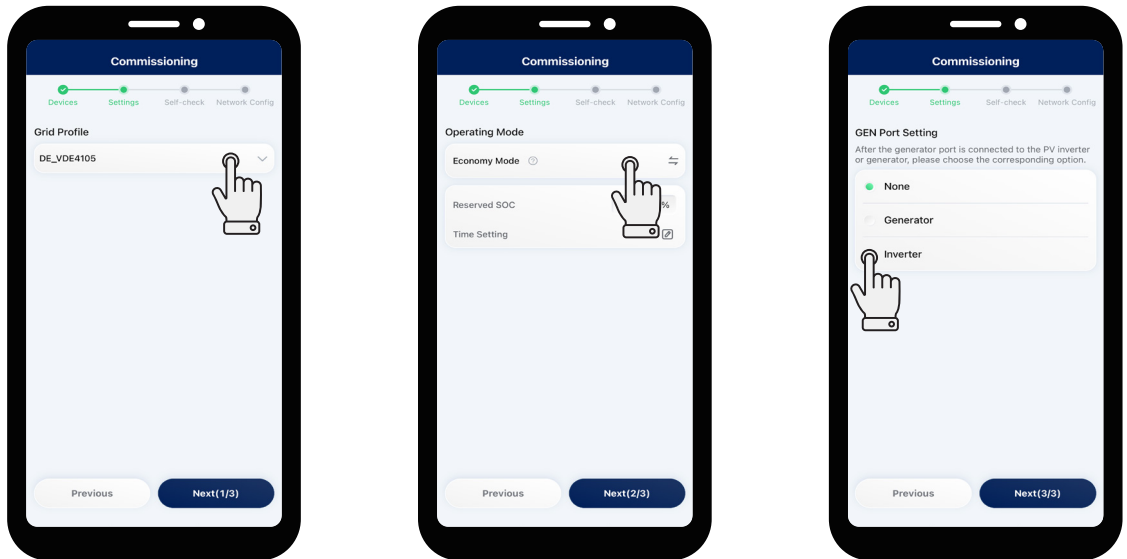

D. Complete the self-check.

- To perform the self-check, tap **Start Testing**.

**NOTE**

- Before this operation, make sure that all DC, AC, and communication cables are correctly connected, and all AC and DC switches are turned on.
- If the result shows the CT is reversely connected, tap **Advanced Settings > Grid CT reverse > Enable** or **PV CT reverse > Enable**, and tap **Save**. For details, refer to [10.3.1 Set Advanced Parameters](#).
- The self-check results are valid only when the system is connected to the grid.

- To skip, proceed to the next step.

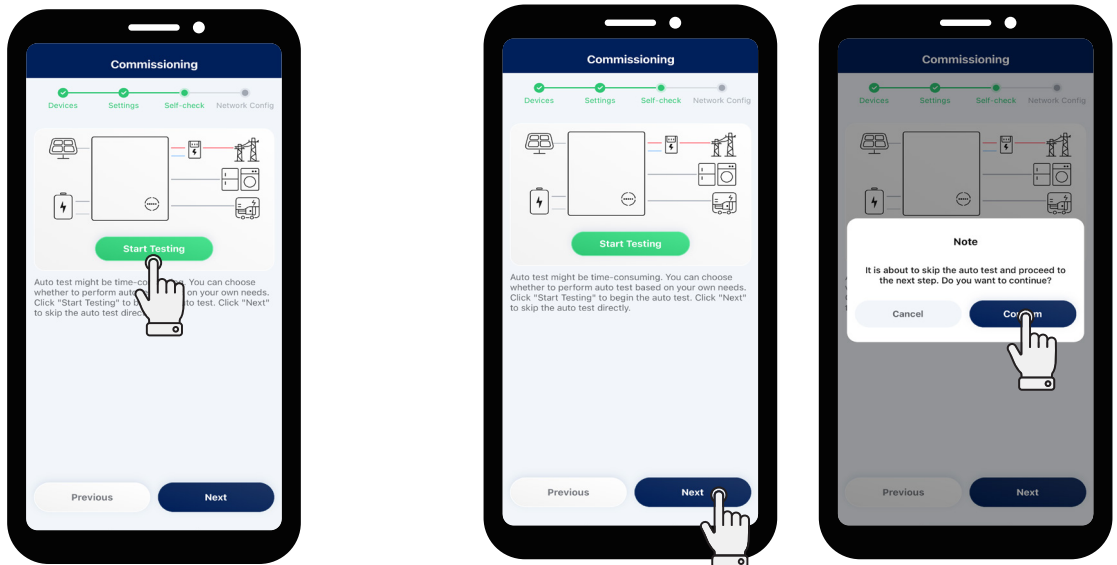

Start Testing

Skip Testing

E. Configure network.

• **Wi-Fi Mode**

- a. Select **Wi-Fi**, choose or enter the Wi-Fi name, enter the password, and tap **Finish**.
- b. When the network connects successfully, tap **Finish**.
- c. When prompted:
  - Tap **Stay at Toolkit** to remain on the Toolkit page.
  - Tap **Go to Settings** to proceed to:
    - the Create Plant page (if no plant has been created), or
    - the Plant Home page (if a plant already exists).



• **LAN Mode**

**NOTE**  
 LAN mode applies only to DTS-WL-G3 when the DTS is connected to the router via an Ethernet cable.

- 1. Select **Ethernet** and tap **Finish**.
- 2. After the connection is successful, tap **Finish**.
- 3. When prompted:
  - Tap **Stay at Toolkit** to remain on the Toolkit page.
  - Tap **Go to Settings** to proceed to:
    - the Create Plant page (if no plant has been created), or
    - the Plant Home page (if a plant already exists).

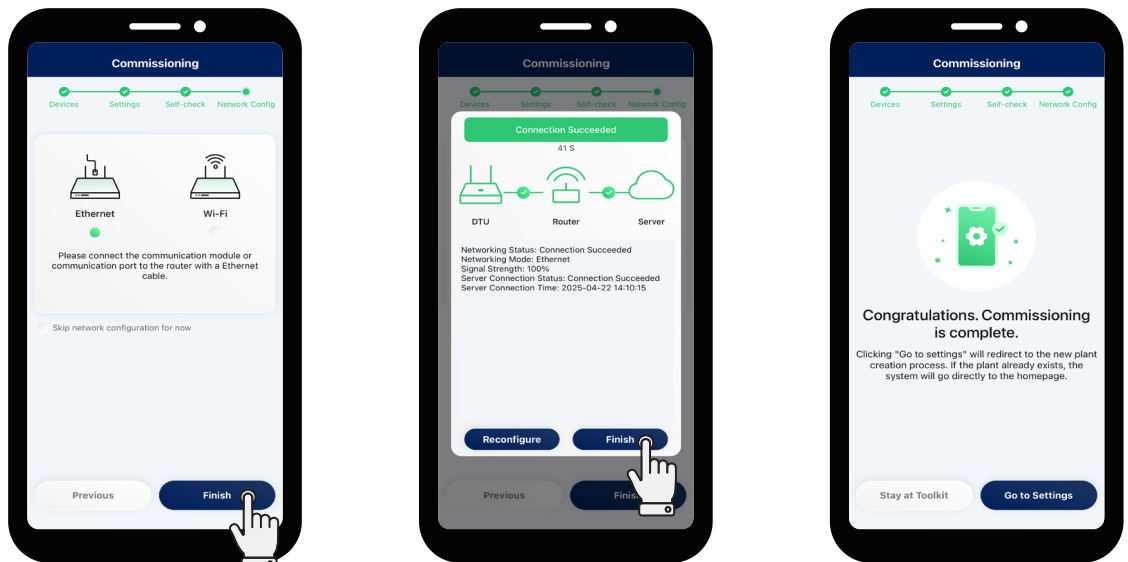

## 10.2 Create a Plant

**Step 1** Tap **+** in the upper left corner.

**Step 2** Enter the basic information and tap **Next**.

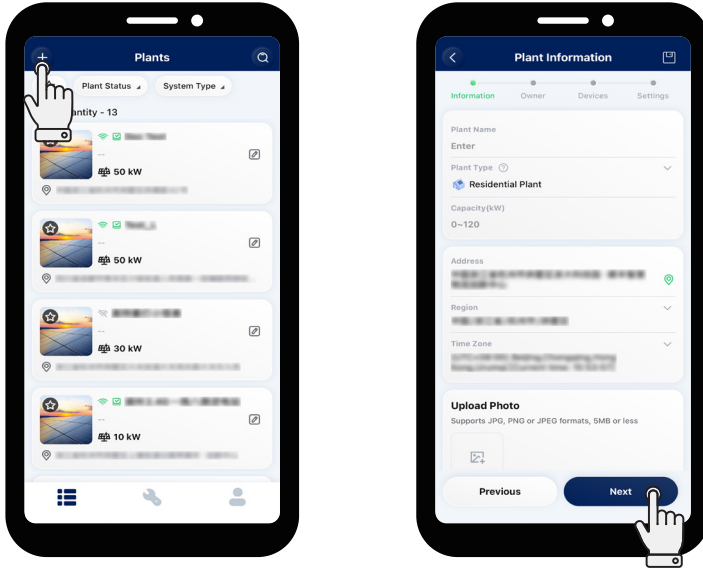

**Step 3** Tap **+** to add an owner.

**Step 4** Enter the login account, name, and password, confirm the password, enter Email and phone number as required, and tap **Save**. (It is recommended to enter an email address to help the owners reset the password when they forget it.)

**Step 5** Tap **Next**.

**NOTE**  
If you don't want to create an owner, tap **+** **Select Owner** to select an existing owner.

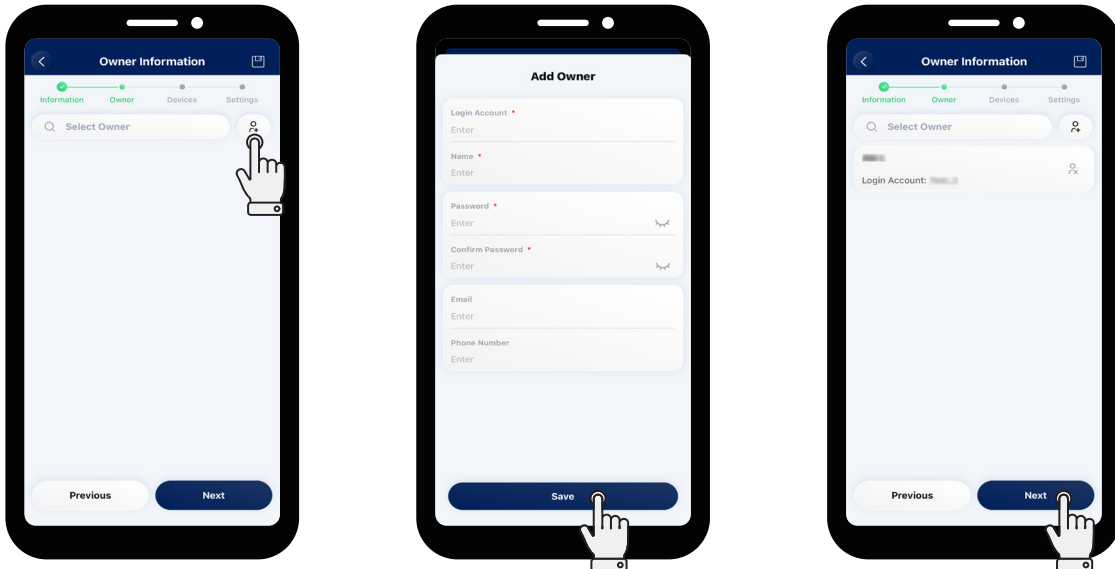

**Step 6** Tap **+** in the lower right.

**Step 7** Enter the DTU SN. The energy storage inverter SN will be automatically identified.

**Step 8** Tap **Finish**.

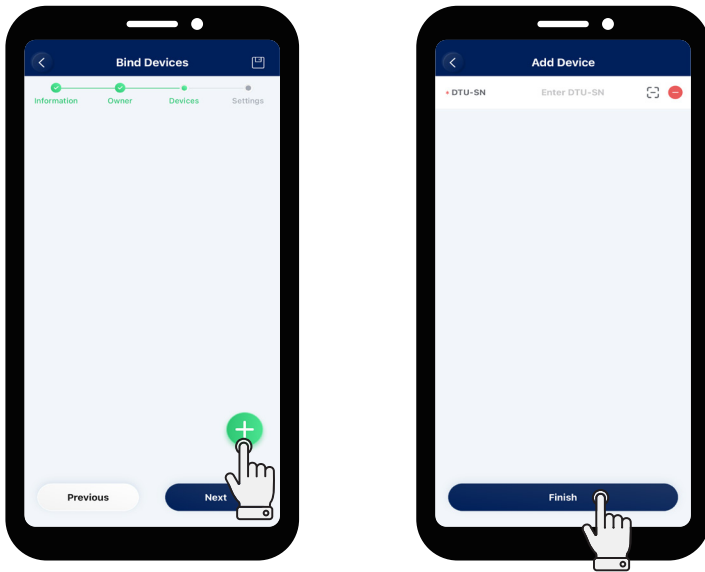

**Step 9** Tap **Next**.

**Step 10** (Optional) Set the currency type and the electricity price per unit (Sell and Buy).

**Step 11** Tap **Finish**.

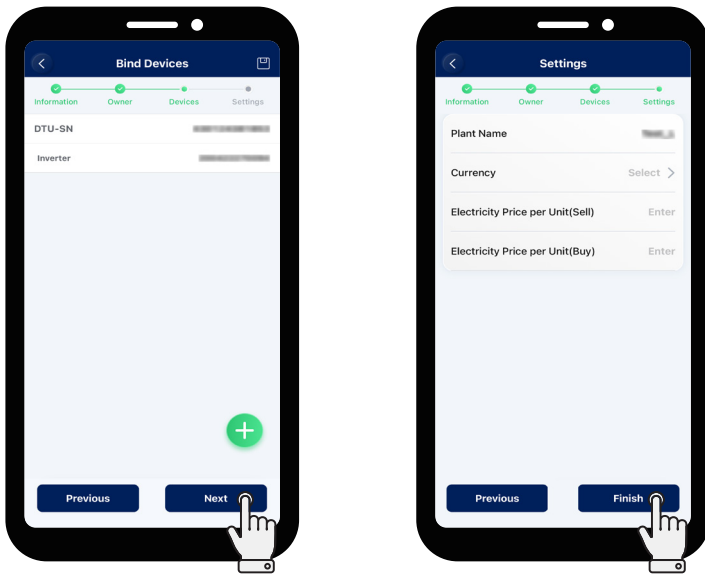

## 10.3 Perform System Settings

### 10.3.1 Set Advanced Parameters

**Step 1** Tap O&M > Toolkit, and tap in the lower right corner.

**Step 2** Tap **Advanced Settings** to set parameters of System, Battery, PV, Emergency Power Supply (EPS), and Generator, and tap **Save**.

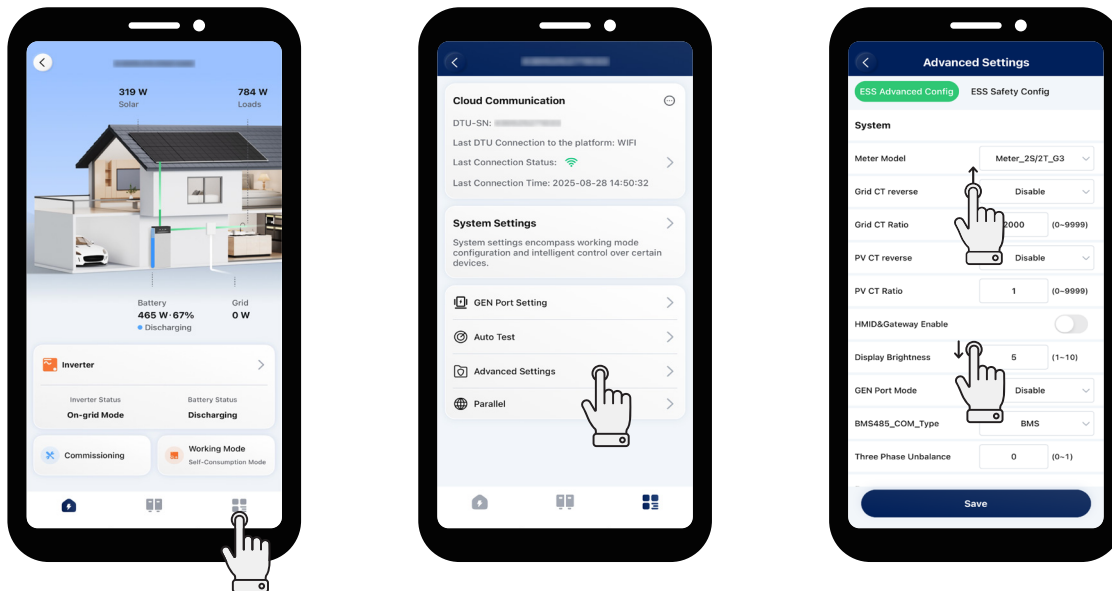

★ System

Parameter	Description	Default Value
Meter Model	<ul style="list-style-type: none"> <li>For a single-phase inverter, select "Single-phase Meter", "Three-phase Meter", "Meter_1S/1T_G3", "Meter_2S/2T_G3", or "CT (Only G3)" according to actual installation.</li> <li>For a three-phase inverter, select "Three-phase Meter", "Meter_1S/1T_G3", "Meter_2S/2T_G3", or "CT (Only G3)" according to actual installation.</li> </ul>	No Meter
Grid CT Reverse	Enable it to get correct sampling current when the grid side CT is reversely connected.	Disable
Grid CT Ratio	Set the grid side CT ratio.	2000
PV CT Reverse	Enable it to get correct sampling current when the PV inverter side CT is reversely connected.	Disable
PV CT Ratio	Set the PV inverter side CT ratio.	2000
HMID&Gateway Enable	Manually enable or disable the HMID or gateway	Disable
Display Brightness	Set the brightness of LED indicators.	10
GEN Port Mode	Select "PV", "Generator", or "Smart Load (Only G3)" based on the actual installation.	Disable
BMS485_COM_Type	<ul style="list-style-type: none"> <li>If the RS485 port is connected to the battery, please select "BMS".</li> <li>If the RS485 port is connected to the microinverter DTU, please select "DTU Com".</li> </ul>	BMS

Three-phase Unbalance	When the loads of the three-phase inverter are not balanced, enable the three-phase unbalance function. It can compensate for each load.	0
-----------------------	--	---

## ★ Battery

Parameter	Description	Default Value
Max. Discharging Power	Set the maximum discharging power.	100%
Max. Charging Power	Set the maximum charging power.	100%
Max. SOC	Set the maximum battery capacity as recommended by the battery manufacturer.	100%
Min. SOC	Set the minimum battery capacity as recommended by the battery manufacturer.	10%
Min. SOC Force Charging Power	Set the power to forcibly charge the battery when the battery SOC falls below the set minimum SOC.	200 W
Reserved SOC Force Charging Power	Set the power to charge the battery when the battery SOC falls below reserved SOC.	2%
Max. BAT Feed-in Power in Peak Time	Set the maximum value of battery feed-in power in peak time.	100%
Max. Grid Charging Power in Off-peak Time	Set the maximum power to charge the battery from the grid in off-peak time.	0 W
Max. BAT Discharging Power in Partial Peak Time	Set the maximum value of battery discharging power in partial peak time.	100%

## ★ PV

Parameter	Description	Default Value
MPPT Global Scan	If the PV modules are shaded, enable this function.	Disable

## ★ Emergency Power Supply (EPS)

Parameter	Description	Default Value
EPS Mode	<ul style="list-style-type: none"> <li>When the EPS port is connected, you can select "EPS" or "UPS". You can select "UPS" when the load keeps power on, and the system will automatically switch between the on-grid mode and the off-grid mode under UPS mode.</li> <li>EPS is characterized by continuous power supply, which means that the loads are powered by bypass under normal power supply, and the DC power will be inverted to supply the loads during power outage, maximizing energy utilization.</li> </ul>	EPS

Parameter	Description	Default Value
EPS Mode	<ul style="list-style-type: none"> <li>UPS (Uninterruptible Power Supply) provides stable voltage and frequency, with extremely strict requirements for switching time. UPS not only operates during power outage, but also can output high quality power supply to ensure normal operation of electric equipment in case of abnormal situations such as overvoltage, undervoltage, and surge.</li> <li>When the inverter is used as a PV inverter, select "Disable".</li> </ul>	EPS
External Bypass	For inverters with an external ATS (EPS) Box, when the external bypass switch is enabled, the inverter EPS port works in the off-grid mode and will not work in the on-grid mode.	Disable
PV Only	In off-grid mode, the hybrid inverter supports operation with PV when there is no battery connection. (This function is not recommended since the system is unstable under this mode.)	Disable

★ Generator

Parameter	Range
GEN Location	None/GenSide. To ensure the normal operation of the generator, please select "GenSide".
GEN Signal Setting	Manual or DI/DO. If the generator cannot be controlled by dry contact, please select "Manual". If the generator can be controlled by dry contact, please select "DI/DO".
Min. Run Time	5-60 min
Max. Run Time	6-10 hour
Protection Interval	5-60 min
Synchronize Time	1-20 min
Shutdown Delay	1-20 min
GEN Rated Power	0-20000 W
High Voltage Limit	0-280 V
Low Voltage Limit	0-180 V
High Frequency Limit	0-70 Hz
Low Frequency Limit	0-59 Hz
Max. GEN Charging Power	0-20000 W

### 10.3.2 Enable DRM Function

- Step 1** Tap O&M > Toolkit, and tap in the lower right corner.
- Step 2** Tap **Advanced Settings** > **ESS Safety Config.**
- Step 3** Select the grid profile in your region and toggle on **DRM Function Activated**.
- Step 4** (For some countries) Set the mode of **DRM Control**.
- Step 5** Tap **Save**.

**NOTE**

- Only the installer can modify grid protection and power quality response mode parameters.
- **DRM Control** for Austria
  - Zero Export (NO): If the contactor is closed, the feed-in power of the inverter will be limited to zero; if the contactor is disconnected, the inverter will work normally.
  - Zero Export (NC): If the contactor is closed, the inverter will work normally; if the contactor is disconnected, the feed-in power of the inverter will be limited to zero.
  - Shutdown (NO): If the contactor is closed, the inverter will be shut down; if the contactor is disconnected, the inverter will work normally.
  - Shutdown (NC): If the contactor is closed, the inverter will work normally; if the contactor is disconnected, the inverter will be shut down.

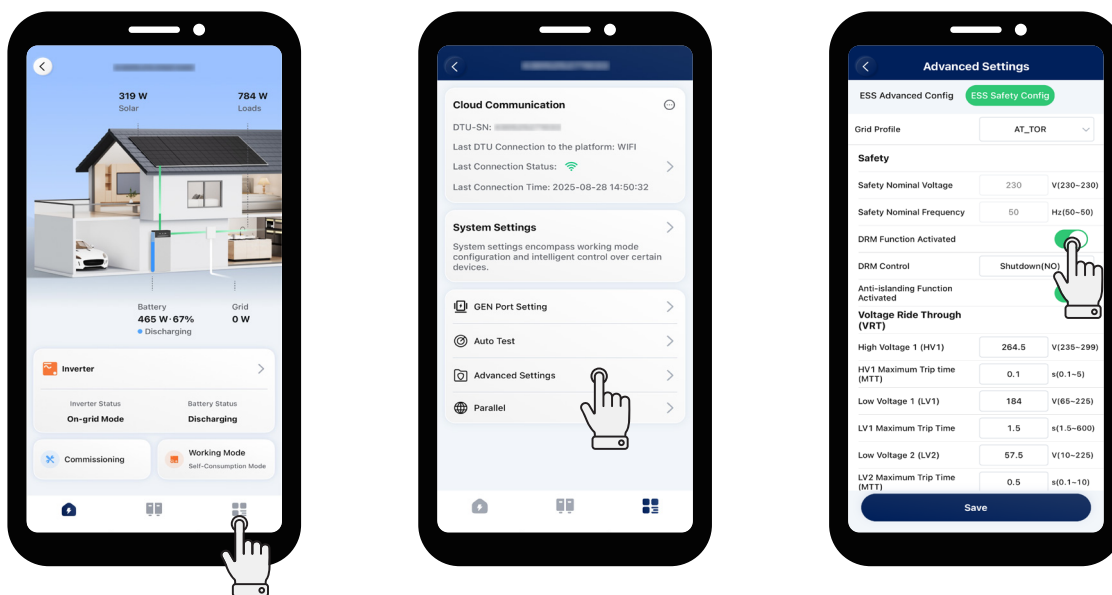

### 10.3.3 Set Export Management Parameters

**NOTE**

- This function is enabled by default, and the default value of Max. Export Power Limit is 100%.
- ESS refers to a single energy storage inverter or a parallel system.
- The energy storage inverter cannot control the output power of other input devices connected to the grid side. It means that the feed-in power cannot be limited to 0 if other input devices are connected to the grid side.
- If no input device is connected to the grid side, Max. Export Power Limit can be set to 0-100%.

- If no input device is connected to the grid side, and you do not need to limit the feed-in power, disable this function or skip this setting.
- If an input device, such as a microinverter, is connected to the grid side, and you do not need to limit the feed-in power, disable this function.
- If you need to limit the feed-in power, follow the instructions below to set Max. Export Power Limit.

**Step 1** Tap **O&M** > **Toolkit**, and tap  in the lower right corner.

**Step 2** Tap  **Advanced Settings** > **ESS Safety Config**, and slide your finger down to the bottom.

**Step 3** Ensure **Generation Control Function (GCF)** is enabled, and set the value of Max. Export Power Limit, and tap **Save**.

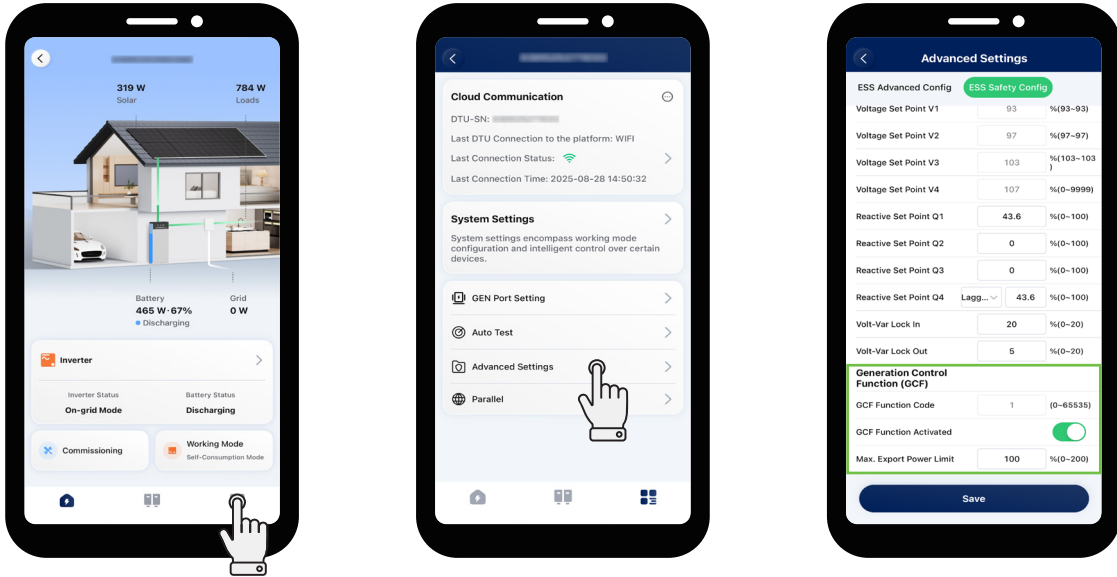

**Scenario 1: Max. Export Power Limit is 0**

The feed-in power of an Energy Storage System (ESS) is 0. If an input device, such as a microinverter, is connected to the grid side, its output power cannot be controlled; it will output power according to its logic.

**Scenario 2: Max. Export Power Limit is 50%**

The maximum allowable feed-in power is 50% of the rated power of ESS. If an input device, such as a microinverter, is connected to the grid side, it can operate at full power, and the energy storage inverter will adjust the output of ESS in real time according to the set Max. Export Power Limit.

**Scenario 3: Max. Export Power Limit is 100%**

The maximum allowable feed-in power is 100% of the rated power of ESS. If an input device, such as a microinverter, is connected to the grid side, it can operate with its full power, and the energy storage inverter will adjust the output of ESS in real time according to the set Max. Export Power Limit.

**Scenario 4: Max. Export Power Limit is 150%**

The maximum allowable feed-in power is 150% of the rated power of ESS. If an input device, such as a microinverter, is connected to the grid side, it can operate with its full power, and the energy storage inverter will adjust the output of ESS in real time according to the set Max. Export Power Limit.

### 10.3.4 Set Working Mode

**NOTE**  
Only one mode can be selected at a time.

After the commissioning, if you want to change the working mode, follow the instructions below.

#### Method One

**Step 1** Tap **O&M** > **Toolkit**, and tap **Working Mode**.

**Step 2** Select one mode, set relevant parameters, and tap **Save**.

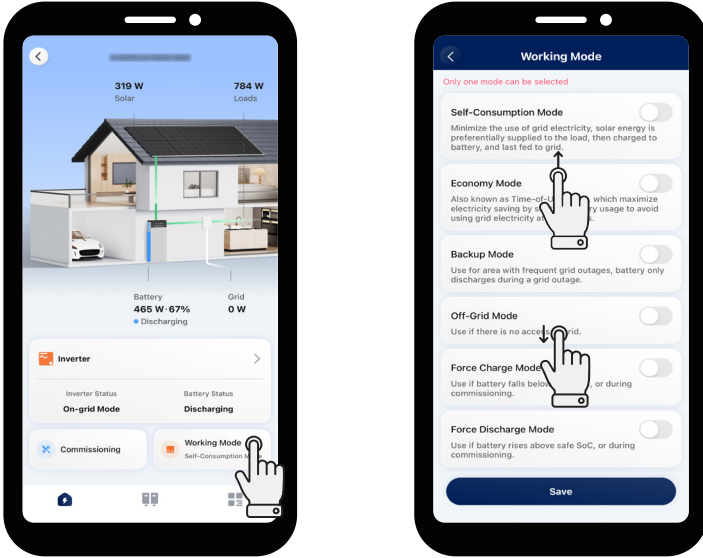

#### Method Two

**Step 1** Tap **O&M** > **Toolkit**, tap **System Settings** in the lower right corner, and tap **System Settings**.

**Step 2** Tap **Working Mode**.

**Step 3** Select one mode, set relevant parameters, and tap **Save**.



### 10.3.5 Set Dry Contact Function

**NOTE**  
Only one mode can be selected at a time.

**Step 1** Tap O&M > Toolkit, tap in the lower right corner, and tap **System Settings**.

**Step 2** Tap **Dry Contact Settings**.

**Step 3** Select one mode, set relevant parameters, and tap **Save**.

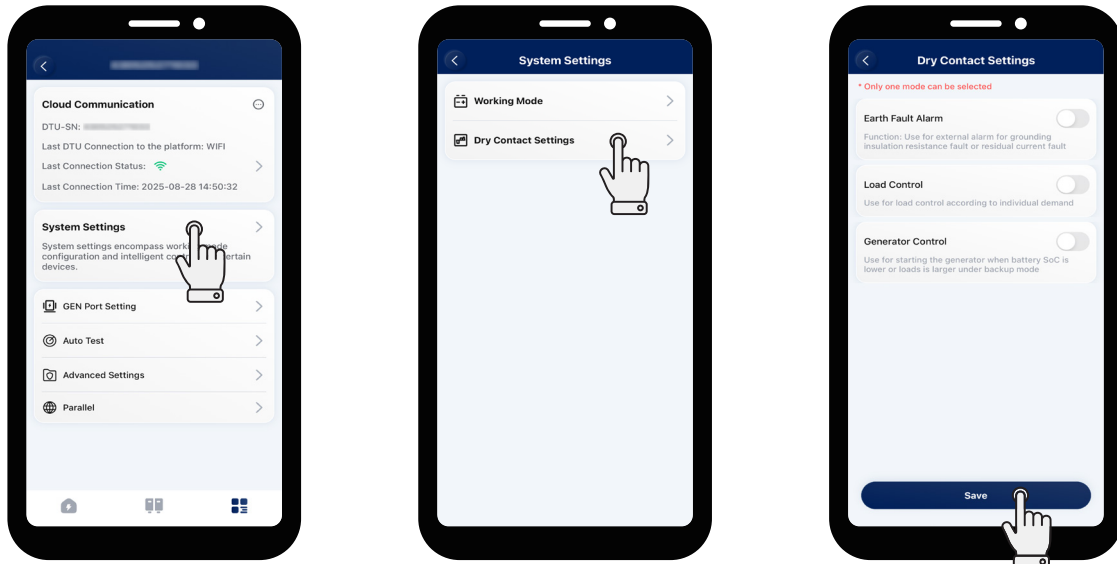

#### ★ Earth Fault Alarm

This function is used for external alarm caused by grounding insulation resistance fault or residual current fault. Disable the external alarm when the load is connected. This function is to produce alarm, not to cause tripping.

#### ★ Load Control

Load control can be used according to individual demand. This setting is to control whether the smart load works or not. There are five modes available as follows.

- **Manual Mode**  
The inverter can supply power to the smart load after you select this mode.
- **Scheduled Mode**  
Set the time period for the smart load to work. The inverter can supply power to the smart load during this set time, and the smart load will be disconnected at other times.
- **Intelligent Mode**

**NOTE**  
Before selecting the intelligent mode, return to page, tap **Advanced Settings**, and set the **Gen Port Mode** to **Smart Load (Only G3)**.

It is necessary to set the value of Min. Running Time and Rated Load Power.

In this mode, the inverter will detect the feed-in power generated by PV in real time. If the feed-in power exceeds the rated load power, the inverter can supply power to the smart load during the pre-set minimum running time. Once the time is up, the inverter will detect the feed-in power again. If the feed-in power is less than the rated load power, the smart load will be disconnected; conversely, the inverter will repeat the above process according to the same logic.

- EPS Port Smart Control

In this mode, battery protection SOC can be set.

In off-grid state, if the battery SOC is higher than the protection SOC, the inverter can supply power to the smart load; if the battery SOC is lower than the protection SOC, the smart load will be disconnected.

- Heat Pump Control (will be coming soon)

The heat pump control function allows users to add up to four runtimes. According to the set power and battery SOC, it can control the start and stop as well as the power of the SG Ready heat pump, maximizing the PV energy utilization.

Parameter	Description
Start Power	When the start power reaches this value, the heat pump control mode is enabled.
Shutdown Power	When the shutdown power reaches this value, the heat pump control mode is disabled.
Battery Starting SOC (Optional)	When the battery SOC reaches this value, the heat pump control mode is enabled.
Battery Shutdown SOC	When the battery SOC reaches this value, the heat pump control mode is disabled.
Min. Single Runtime	When the single runtime reaches this value, the heat pump control mode is disabled.
Max. Single-day Runtime (Optional)	When the running time of the day reaches this value, the heat pump control mode is disabled.
Runtime Settings	Up to 4 operating periods can be set.

★ **Generator Control**

- Exercise Mode

The generator starts regularly during the preset period to ensure the operation of the generator.

Parameter	Description
Frequency	It allows the generator to start regularly at this frequency.
Start Time	It allows the generator to start regularly at this time.
Duration	The generator will stop running after this duration.

- Running Mode

This mode is the off-grid operation mode of the generator, including manual mode and auto mode.

- ▷ Manual Mode

The manual mode is used to turn on or turn off the generator manually.

- ▷ Auto Mode

The auto mode is used to turn on or turn off the generator according to the battery capacity. The auto mode only supports generators controlled by Dry Contact. Otherwise, please select the manual mode.

Parameter	Description
GEN Start SOC	In off-grid mode, start the generator when the battery capacity is lower than the safety SOC.
GEN Shutdown SOC	In generator mode, shut down the generator when the battery capacity is higher than the safety SOC.
Quiet Time	During the quiet time, the generator is disabled. If you set this time, it will affect the normal use of electricity.

- Battery Charge Time

Parameter	Description
Battery Charge Time	The generator will charge the battery during the preset period. Please choose the time period when the PV power is low to avoid wasting PV power.

## 10.4 Upgrade the Firmware

**NOTE**

During the firmware upgrade, do not power off the device.

When you enter the plant overview interface, there will be a pop-up window if there is a new firmware version.

**Method One**

**Step 1** Tap the target plant.

**Step 2** Tap **Upgrade**.

**Step 3** Tap **Upgrade**.

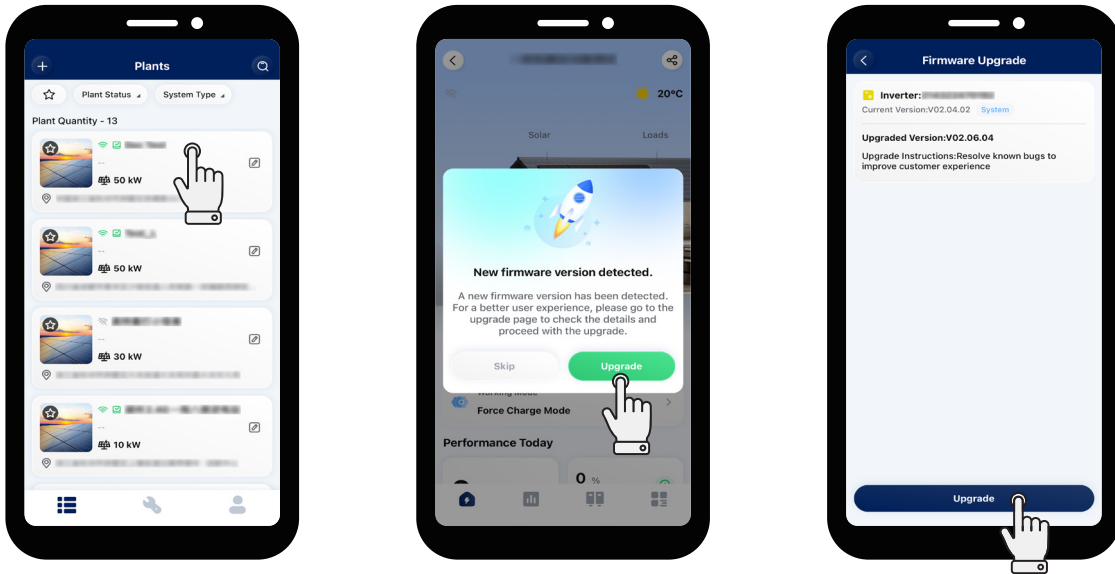

**Method Two**

If you have tapped **Skip** to perform other operations, you can also follow the instructions below to upgrade the firmware.

**Step 1** Tap  in the lower right corner.

**Step 2** Tap  **Firmware Upgrade > Upgrade**.

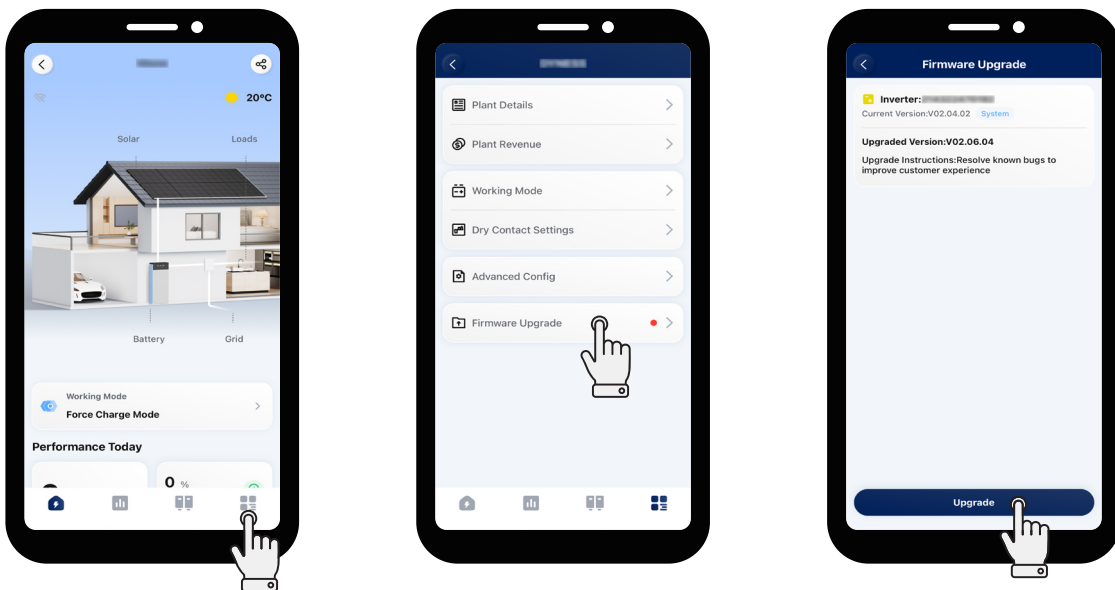

# 11 System Maintenance

## 11.1 System Power-off

**NOTICE**  
Wait at least 5 minutes after the LED indicators are off to release the internal energy.

- Step 1** Stop the product from working via the S-Miles App.
- Step 2** Press the power button.
- Step 3** Disconnect the AC breaker between the inverter and the grid.
- Step 4** Rotate the DC switch to "OFF" if the inverter is connected to the PV strings.
- Step 5** Check whether the inverter indicators are off.

## 11.2 Routine Maintenance

Check Item	Check Method	Maintenance Interval
System Operation Status	<ul style="list-style-type: none"> <li>Check whether the device is damaged or deformed.</li> <li>Check whether there is an abnormal sound when the device is working.</li> <li>Check whether the device parameters are set correctly.</li> </ul>	Once every 6 months
Electrical Connection	<ul style="list-style-type: none"> <li>Check whether the cables are firmly connected and intact; in particular, ensure that the parts being contacted with the metal surface are not scratched.</li> <li>Check whether the waterproof plugs or covers of unused ports are firmly in place.</li> </ul>	The first inspection is 3 months after the first installation, and the subsequent inspections can be carried out once every 6 to 12 months.
Grounding Reliability	Check whether the ground cables are firmly connected.	The first inspection is 3 months after the first installation, and the subsequent inspections can be carried out once every 6 to 12 months.

### 11.3 Troubleshooting

When the system is in alarm, please log in to the S-Miles App to review. The possible causes and their troubleshooting are shown as follows.

Display	Possible Cause	Handling Suggestions
Grid Overvoltage	The grid voltage is higher than the permissible range.	<p>Generally, the inverter will reconnect to the grid after the grid recovers. If the alarm occurs frequently:</p> <ol style="list-style-type: none"> <li>1. Make sure the ESS safety configuration of the inverter is set correctly.</li> <li>2. Make sure that the grid voltage in your area is stable and within the normal range.</li> <li>3. Check whether the cross-sectional area of the AC cable meets the requirement.</li> <li>4. If the alarm persists, contact Hoymiles technical support team.</li> </ol>
Grid Undervoltage	The grid voltage is lower than the permissible range.	<p>Generally, the inverter will reconnect to the grid after the grid recovers. If the alarm occurs frequently:</p> <ol style="list-style-type: none"> <li>1. Make sure the ESS safety configuration of the inverter is set correctly.</li> <li>2. Make sure that the grid voltage in your area is stable and within the normal range.</li> <li>3. Check whether the AC cable is firmly in place.</li> <li>4. If the alarm persists, contact Hoymiles technical support team.</li> </ol>
Grid Overfrequency	The grid frequency is higher than the permissible range.	<p>Generally, the inverter will reconnect to the grid after the grid recovers. If the alarm occurs frequently:</p> <ol style="list-style-type: none"> <li>1. Make sure the ESS safety configuration of the inverter is set correctly.</li> <li>2. Make sure that the grid frequency in your area is stable and within the normal range.</li> <li>3. If the alarm persists, contact Hoymiles technical support team.</li> </ol>
Grid Underfrequency	The grid frequency is lower than the permissible range.	
No Grid	The inverter detects that there is no grid connected.	<p>Generally, the inverter will reconnect to the grid after the grid recovers. If the alarm occurs frequently:</p> <ol style="list-style-type: none"> <li>1. Check whether the grid supply is reliable.</li> <li>2. Check whether the AC cable is firmly in place.</li> <li>3. Check whether the AC cable is correctly connected.</li> <li>4. Check whether the AC circuit breaker is disconnected.</li> <li>5. If the alarm persists, contact Hoymiles technical support team.</li> </ol>

Display	Possible Cause	Handling Suggestions
RCD Fault	The residual leakage current is too high.	<ol style="list-style-type: none"> <li>1. The alarm can be caused by high ambient humidity, and the inverter will reconnect to the grid after the environment is improved.</li> <li>2. If the environment is normal, check whether the AC and DC cables are well insulated.</li> <li>3. If the alarm persists, contact Hoymiles technical support team.</li> </ol>
PV Reverse Connection	The inverter detects that the PV strings are reversely connected.	<ol style="list-style-type: none"> <li>1. Check whether the corresponding string is of reverse polarity. If so, disconnect the DC switch and adjust the polarity when the string current drops below 0.5 A.</li> <li>2. If the alarm persists, contact Hoymiles technical support team.</li> </ol>
PV Undervoltage	The PV voltage is lower than the permissible range.	<ol style="list-style-type: none"> <li>1. Check whether the DC cable is firmly in place.</li> <li>2. Check whether there is a PV module shaded. If so, remove the shade and ensure the PV module is clean.</li> <li>3. Check whether the PV module is in abnormal aging.</li> <li>4. If the alarm persists, contact Hoymiles technical support team.</li> </ol>
PV Overvoltage	The PV voltage is higher than the permissible range.	<ol style="list-style-type: none"> <li>1. Check the specification and numbers of corresponding string PV modules.</li> <li>2. If the alarm persists, contact Hoymiles technical support team.</li> </ol>
Over Temperature	The temperature inside the inverter is higher than the permissible range.	<ol style="list-style-type: none"> <li>1. Make sure that the installation complies with the instructions from the User Manual.</li> <li>2. Check whether the alarm "Fan Fault" occurs. If so, replace the faulty fan.</li> <li>3. If the alarm persists, contact Hoymiles technical support team.</li> </ol>
ISO Fault	The insulation impedance of the PV string to the ground is too low.	<ol style="list-style-type: none"> <li>1. Use a multimeter to determine if the resistance between the earth and the inverter frame is close to zero. If not, please ensure that the connection is good.</li> <li>2. If the humidity is too high, an isolation fault may occur. Attempt to restart the inverter. If the fault persists, check it again when the weather turns fine.</li> <li>3. Check the resistance to ground from the PV module/cable. Take corrective measures in case of leading to a short circuit or damaged insulation layer.</li> <li>4. If the alarm persists, contact Hoymiles technical support team.</li> </ol>

Display	Possible Cause	Handling Suggestions
Arc Fault	The inverter detects that there is an arc fault.	<ol style="list-style-type: none"> <li>1. Disconnect the DC switch and check whether DC cables are damaged and whether the wiring terminals are loose or in poor contact. If so, take corresponding corrective measures.</li> <li>2. After taking corresponding measures, reconnect the DC switch.</li> <li>3. If the alarm persists, contact Hoymiles technical support team.</li> </ol>
EPS Load Overpower	The EPS load power is higher than the permissible range.	<ol style="list-style-type: none"> <li>1. Reduce the power of EPS loads, or remove some EPS loads. The inverter will restart automatically.</li> <li>2. If the alarm persists, contact Hoymiles technical support team.</li> </ol>
Meter Reverse Connection	The inverter detects that the Meter or CT is reversely connected.	<ol style="list-style-type: none"> <li>1. Make sure that the installation complies with the instructions from the User Manual.</li> <li>2. If the alarm persists, contact Hoymiles technical support team.</li> </ol>
Meter Communication Fault	The inverter detects that there is a meter communication fault.	<ol style="list-style-type: none"> <li>1. Check whether the Meter communication cable and terminal are abnormal.</li> <li>2. Reconnect the Meter communication cable.</li> <li>3. If the alarm persists, contact Hoymiles technical support team.</li> </ol>
Battery Reverse Connection	The inverter detects that the battery wirings are reversely connected.	<ol style="list-style-type: none"> <li>1. Check the battery for polarity correctness, and correct it if necessary.</li> <li>2. If the alarm persists, contact Hoymiles technical support team.</li> </ol>
Battery Voltage Fault	The battery voltage is higher than the permissible range.	<ol style="list-style-type: none"> <li>1. Check if the battery input voltage is within the normal range.</li> <li>2. If the alarm persists, contact Hoymiles technical support team.</li> </ol>
BMS Communication Fault	The inverter detects that there is a BMS communication fault.	<ol style="list-style-type: none"> <li>1. Check whether the BMS communication cable and terminal are abnormal.</li> <li>2. Reconnect the BMS communication cable.</li> <li>3. If the alarm persists, contact Hoymiles technical support team.</li> </ol>
BMS Battery Alarm	The inverter detects that there is a battery fault from BMS.	Try to restart the battery. If the fault persists, contact the battery manufacturer.
BMS Battery Fault	The inverter detects that there is a battery fault from BMS.	Try to restart the battery. If the fault persists, contact the battery manufacturer.
Relay Self-check Fault	The inverter detects that there is a relay self-check fault.	Try to restart the inverter. If the fault persists, contact Hoymiles technical support team.

## 12 Decommissioning

### 12.1 Removing the Product

**Step 1** Power off the product as described in [11.1 System Power-off](#).

**Step 2** Disconnect all cables.

**Step 3** Remove the device from the wall.

### 12.2 Packing the Product

If the original package is available, put the product and its accessories into the package and keep them in a dry and proper place.

If the original package is not available, put the product and its accessories into a suitable package. The package should be easy to remove, can bear the weight of the product, and can be sealed properly.

### 12.3 Disposing of the Product

If the product can not be used and needs to be disposed of, dispose of the product and its accessories in accordance with the European Directive 2002/96/EC on Waste Electrical and Electronic Equipment (WEEE).

In accordance with the WEEE and its implementation in national law, the electrical devices must be collected separately and recycled in an environmentally responsible manner. We recommend that you return your used device to your dealer or obtain information regarding a local, authorized collection and disposal system. Failure to comply with this EU Directive may result in a negative impact on the environment.

# 13 Technical Datasheet

## 13.1 HiOne-(8-20)T-G3

Model	HiOne-8T-G3	HiOne-10T-G3	HiOne-12T-G3	HiOne-16T-G3	HiOne-20T-G3
<b>Battery</b>					
Battery type	Li-ion				
Battery voltage range (V)	720-950				
Compatible battery model	HiOne-8B-G3				
Number of modules	1-8 <sup>(1)</sup>				
<b>PV Input</b>					
Recommended max. PV power (W)	16000	20000	24000	32000	40000
Max. input voltage (V)	1000				
Rated voltage (V)	720				
Start-up voltage (V)	170				
MPPT voltage range (V)	150-950				
Max. input current (A)	20/20/20		20/20/20/20		
Max. short circuit current (A)	30/30/30		30/30/30/30		
MPPT number/Max. input strings number	3/3		4/4		
<b>AC Output</b>					
Rated output power (W)	8000	10000	12000	16000	20000
Max. on-grid output apparent power (VA)	8800	11000	13200	17600	22000
Max. output current (A)	13.3	16.7	20.0	26.7	33.3
Max. off-grid output apparent power (VA) <sup>(2)</sup>	12000 (10s)	15000 (10s)	18000 (10s)	24000 (10s)	30000 (10s)
Grid form	3L/N/PE				
Rated AC output voltage (V)	380/400				
Rated grid frequency (Hz)	50/60				
Power factor	>0.99 (0.8 leading-0.8 lagging)				
THDi (@rated output)	<3%				
<b>Efficiency</b>					
Max. efficiency	98.5%				
EU efficiency	98.0%				
<b>Protection</b>					
Anti-islanding protection	Integrated				
PV string input reverse polarity protection	Integrated				
Insulation resistor detection	Integrated				
Residual current monitoring unit	Integrated				
AC overcurrent protection	Integrated				
AC short circuit protection	Integrated				
AC overvoltage and undervoltage protection	Integrated				
Surge protection	DC Type II / AC Type II				
<b>General</b>					
Dimensions (W × H × D [mm])	620 × 360 × 255				
Weight (kg)	31				
Mounting	Wall-mounted / Floor-standing				
Operating temperature (°C)	-30 to +65 (>45, derating)				
Relative humidity	0-95%, no condensation				
Cooling	Natural convection		Intelligent air cooling		
Topology	Non-isolation				
Altitude (m)	≤4000				
Protection degree	IP66				
Noise (dB)	<35		<55		
User interface	LED & App				
Communication	RS485, Bluetooth, Wi-Fi / Ethernet (optional)				
Warranty	10 Years (standard), 12.5 Years (optional)				

(1) Up to four modules can be stacked in one battery tower.

(2) Applicable only when the inverter is connected to Hoymiles gateway.

## 13.2 HiOne-8B-G3

Model	HiOne-8B-G3
<b>Battery Data</b>	
Battery type	LiFePO <sub>4</sub>
Cell capacity (Ah)	314
Total energy (kWh)	8
Max. charging/discharging power (kW)	4
Peak discharge power (kW)	6 (10s)
Max. stackable quantity	4
Max. parallel quantity	2
<b>General</b>	
Dimensions (W × H × D [mm])	620 × 360 × 255 (single pack)
Weight (kg)	67
Mounting	Wall-mounted / Floor-standing
Installation environment	Indoor / Outdoor
Charging/discharging temperature (°C)	-20 to +55
Protection degree	IP66
Cooling	Natural convection
Altitude (m)	≤4000
Warranty	10 Years (standard), 12.5 Years (optional)



## Hoymiles Power Electronics Inc.

 Floor 6, Building 5, 99 Housheng Road,  
Gongshu District, Hangzhou 310015 P. R. China

 +86 571 2805 6101

 [hoymiles.com](http://hoymiles.com)

 [service@hoymiles.com](mailto:service@hoymiles.com)  
[support@hoymiles.com](mailto:support@hoymiles.com)

